

# SERVICE BULLETIN

# MERCURY OUTBOARDS

Number: 77-14

Date: 5/25/77



CIRCULATE TO:	SERVICE MGR.	PARTS MGR.	MECHANICS	Place in Your "Service Bulletin" Binder
---------------	--------------	------------	-----------	---

- A. New Propellers for Merc 1750
- B. New Propellers for 1978 Merc 800-thru-1500 (In-Line)

## A. NEW PROPELLERS for MERC 1750

(Attach Service Bulletin Sticker to Section 2B Index Page of Your Service Manual.)

Soon to be introduced is a new line of Quicksilver 3-blade propellers for Merc 1750 models that will back-fit thru 1976 models. They will only be available cupped.

The new line will adapt to any 1976 and later Merc 1750 model by simply replacing the forward thrust hub with a new forward thrust hub, rear thrust hub and tab washer (listed below). (Figure 1)

- A-77987 — Forward Thrust Hub
- A-14-31210 — Tab Washer
- A-12-31211 — Rear Thrust Hub

### NEW 3-BLADE PROPELLERS

Part No.	Diameter	Pitch
A-48-78126A4	13-3/8"	25"
A-48-78124A4	13-1/2"	23"
A-48-78122A4	13-3/4"	21"
A-48-78120A4	14"	19"
A-48-78118A4	14-1/2"	17"
A-48-78116A4	15-1/4"	15"
A-48-78114A4	16"	13"
A-48-78112A4	16"	11"

(Metric Conversion: 1" = 2.54cm)

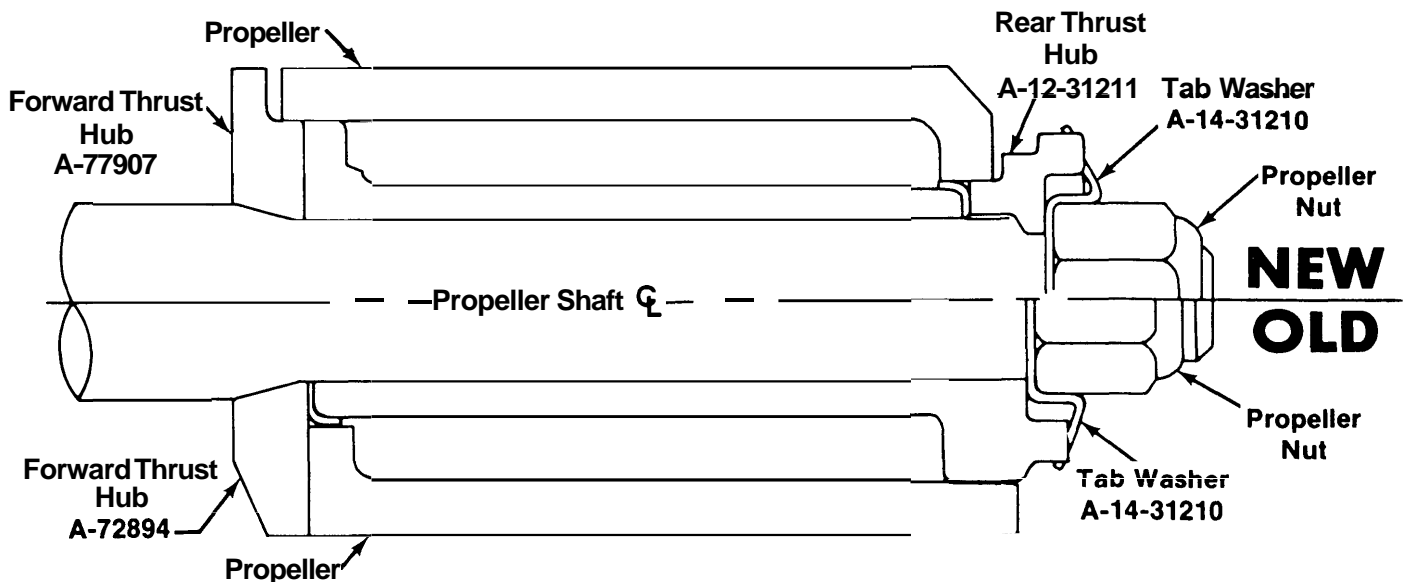

Figure 1. Propeller Installation

(OVER)

All 1978 Merc 1750 models will be shipped with the new thrust hub, rear thrust hub and tab washer that are designed for use with the new propellers. We recommend using the new propellers with these 1978 models; however, the current propeller line can be utilized if the new forward thrust hub (A-77987) is replaced by the old style forward thrust hub (A-72394), then adding the old rear thrust hub (A-12-31211) and tab washer (A-14-31210). (Figure 1)

## B. NEW PROPELLERS for 1978 MERC 800-thru-1500 (In-Line)

(Attach Service Bulletin Slicker to Section 2B Index Page of Your Service Manual.)

A new line of Quicksilver 3-blade aluminum propellers for Merc 800-thru-1500 in-line models will be introduced soon. They will only be available cupped with the new Hi-Rake blade design, which provides improved performance with less chance of ventilation (breaking loose) in turns. Also, with Power Trim installed, the new propellers will hold better when the engine is trimmed out.

The new line will adapt to any 1963 and newer Merc 6-cyl. in-line model and 4-cyl. in-line Merc 650-800-850 models by simply replacing the forward and rear thrust hubs with a new forward thrust hub and tab washer (listed below). (Figure 2)

A-75202 — Forward Thrust Hub

A-14-31210 — Tab Washer

### NEW 3-BLADE ALUMINUM PROPELLERS

Part No.	Diameter	Pitch
A-48-77350A4	12-1/2"	23"
A-48-77348A4	12-3/4"	21"
A-48-77346A4	13"	19"
A-48-77344A4	13-1/4"	17"
A-48-77342A4	13-3/4"	15"
A-48-77340A4	14"	13"
A-48-77338A4	14"	11"

(Metric Conversion: 1" = 2.54cm)

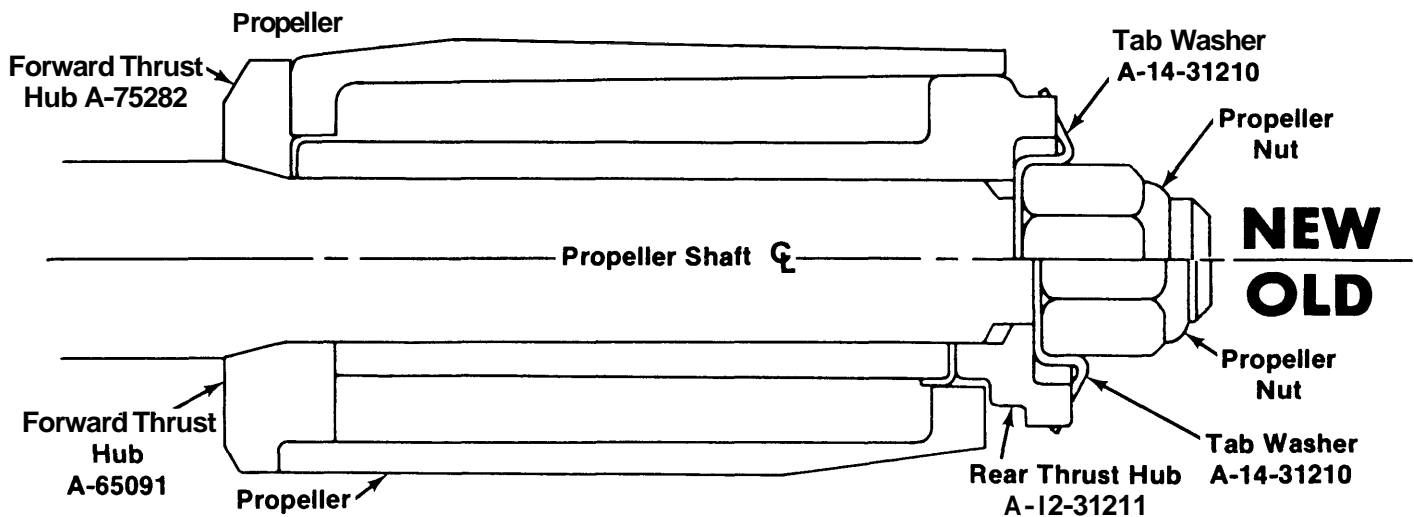

Figure 2. Propeller Installation

All 1978 Merc 800-thru-1500 in-line models will be shipped with the new thrust hub and tab washer that are designed for use with the new propellers. We recommend using the new propellers with these 1978 models; however, the current propeller line can be utilized if the new forward thrust hub (A-75282) is replaced by the old style forward thrust hub (A-65091), then adding the old rear thrust hub (A-12-31211) and tab washer (A-14-31210). (Figure 2)