

NUMBER: 79-9

DATE: 6/6/79

---

**CIRCULATE TO:  
SERVICE MANAGER  
PARTS MANAGER  
MECHANICS**

- A. V-6 Outboard E-Z Shift Gear Housing Shift Cams and Cam Followers**
- B. Power Trim Pumps - Valve Body Mounting Screw Torque**
- C. Hard Starting - V-150 1979 Model**
- D. Water Pressure Gauge Kit - C-91-79250A1**

**A. V-6 OUTBOARD E-Z SHIFT GEAR HOUSING SHIFT CAMS and CAM FOLLOWERS**

*(Attach Service Bulletin Sticker on P. 7C-11 in Your Service Manual.)*

Should it become necessary to replace either the cam or cam follower in the following listed outboards, both the cam and cam follower **MUST BE** replaced. Order Part No. A-89594A1, which consists of the cam and cam follower.

<b>Merc Model</b>	<b>Year</b>	<b>Serial Nos.</b>
v-200	1978-79-80	All
V-175	1979	5393737 and Up
V-150	1979	5432421 and Up

**B. POWER TRIM PUMPS - VALVE BODY MOUNTING SCREW TORQUE**

*(Attach Service Bulletin Sticker on P. 8C-9 in Your Service Manual.)*

Occasional malfunction of Power Trim pumps, due to loose valve assemblies, have been reported. If this problem should occur, remove the valve body and examine for seal damage, replace any necessary parts and reinstall the valve body. Torque mounting screws to 70 in. lbs. (81kg-cm).

**C. HARD STARTING - V-150 1979 Model**

*(Attach Service Bulletin Sticker on P. 5B-19 in Your Service Manual.)*

Hard starting has been experienced on some V-150 1979 engines that are equipped with WH-9 type carburetors. Since this carburetor cannot be primed by overpowering the fuel primer bulb, the following modifications may be required.

1. Remove the plate assembly from the carburetors and remove the choke shutters and Part No. A-73619 retainers. Care must be taken when removing the shutter screws, since they are Loctited and staked to prevent loosening.
2. Scrape off the area of the outermost carburetor to plate gasket in the area where it has swelled into the choke shaft slot. (Figure 1) **THIS AREA MUST BE FLUSH WITH THE ORIGINAL GASKET SURFACE.**
3. Remove the choke shaft and lever assembly from the choke plate and replace the windup springs with the new springs (A-24-88578). Preload these new springs only one-half turn.
4. Reinstall the choke shaft into the plate and fasten the shutter screws in place with Loctite No. 35 (C-92-59238). Be certain that the shutters are aligned properly on the shaft so that, when the shutter is closed, it is centered in the hole in the plate and does not bind.

(OVER)

5. The new spring is axially longer than the old spring and may cause the shutter and A-76129 lever to bind on the choke plate. If this occurs, then the lever must be modified according to Figure 2.
6. If none of the shafts bind, replace the A-73619 retainers. If these cause binding, that cannot be corrected by realignment, remove them permanently.
7. Install a A-19-90399 plug (choke plate) in the cavity between the choke shutters (Figure 3) of adjacent cylinders and the choke plate to carburetor gasket for each carburetor and replace the choke plate assembly. (Figure 3) Check for binding after installation.

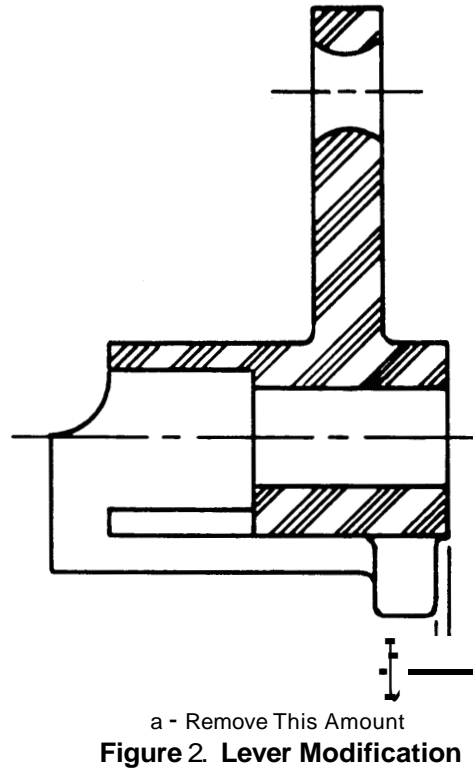
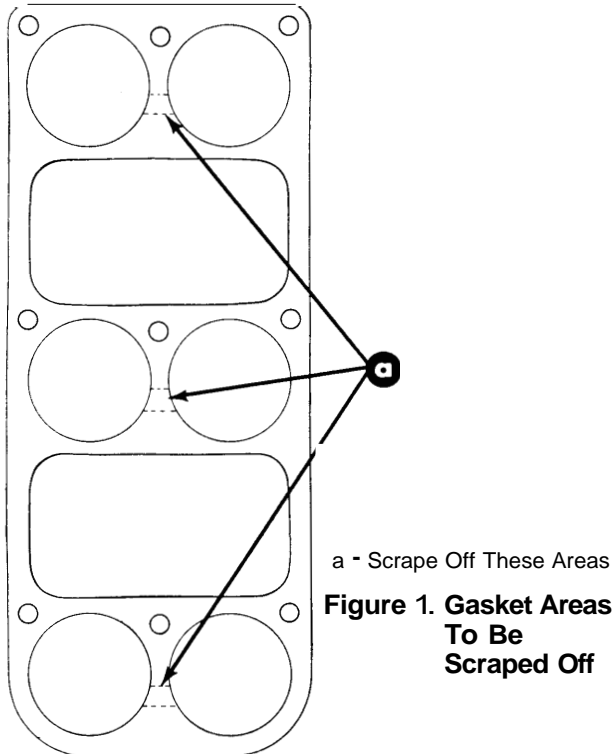

**8. Finally, all owners of these motors should be reminded of the correct starting procedure, as follows:**

- A. A fully charged battery is essential.
- B. Advance the throttle lever to the full warm-up position.
- C. Pump the primer bulb until it is firm. Any "sponginess" indicates that the primer is not functioning properly and must be replaced. The fuel bowls must be full of fuel.
- D. Engage the choke button and do not release until the engine has started.
- E. Turn the key on and crank. The engine will start within 20 seconds. If it does not start, check for ignition, fuel and the proper alignment of the choke shutters to the choke plate. **DO NOT** run the battery down and burn out the starter motor.

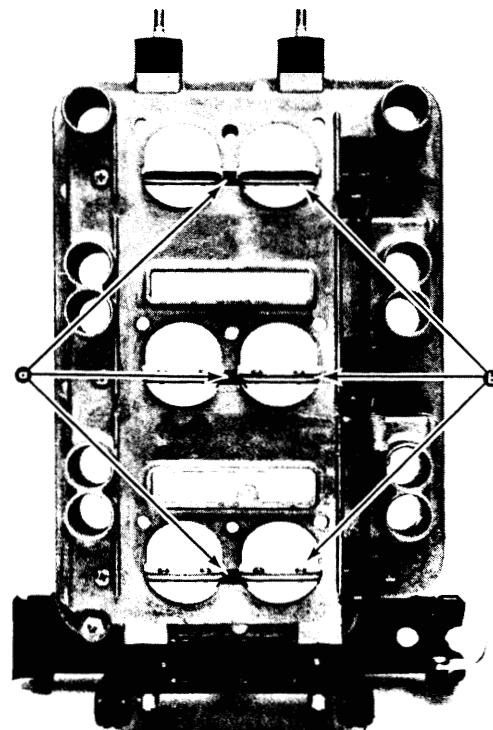

**Figure 3. Plug Installation**

F. Continue choking, even after the motor starts, until the motor runs evenly.

Parts required are as follows:

**1 Each A-19-90399A1**

**Plug - Choke Plate**

**3 Each A-24-aa578**

**Spring - Choke Shaft**

**D. WATER PRESSURE GAUGE KIT - C-91-79250A1**

*(Attach Service Bulletin Sticker on P. 10D-4 in Your Service Manual.)*

A water pressure gauge now is available to trouble-shoot the cooling system on V-6 outboards. Kit includes installation instructions and a troubleshooting chart.

**C-91-79250A1**

**Water Pressure Gauge Kit**