

- A. Carburetor Identification – V6 Outboards
- B. Carburetor Throttle Shutter Fit – V6 Outboards
- C. Front Cowl Latch Retorque – 1989 Model V6 Outboards
- D. Oil Injection Pump Identification – 3 Cyl. Models 70-75-80-90- and 4 Cyl. Models 100-115
- E. Driveshaft Bearing Race Installation – Model 35-40-50-60
- F. Test Lead Assembly P/N 91-814746 – V6 Outboard with EFI

A. CARBURETOR IDENTIFICATION – V6 OUTBOARDS

The carburetor identification number on V6 carburetors is no longer located on the carburetor mounting flange. The carburetor identification number is now located as shown in the following illustration. Figure 1.

Vendor	Carb Identification	Carb Position	Day of Mfg.	Year of Mfg.
WH	46-	1-Top 2-Middle 3-Bottom 1	280	8

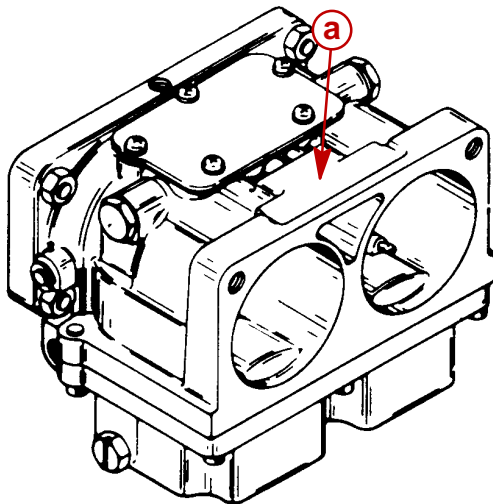

Figure 1.

a - New Location of Carb Identification Number

B. CARBURETOR THROTTLE SHUTTER FIT V6 OUTBOARDS

A reminder is in order, that whenever making any timing and synchronizing to V6 Outboards, the throttle shutters must fit properly in the carburetor bore. Should the throttle shutters not fit properly, the timing and synchronizing will not come out right and performance will suffer.

Make certain all throttle shutters are closing to the best possible fit in the carburetor bore. Adjust each individual throttle shutter as necessary. Carburetor must be removed and throttle shutters checked from the rear of the carburetor. See Figure 2.

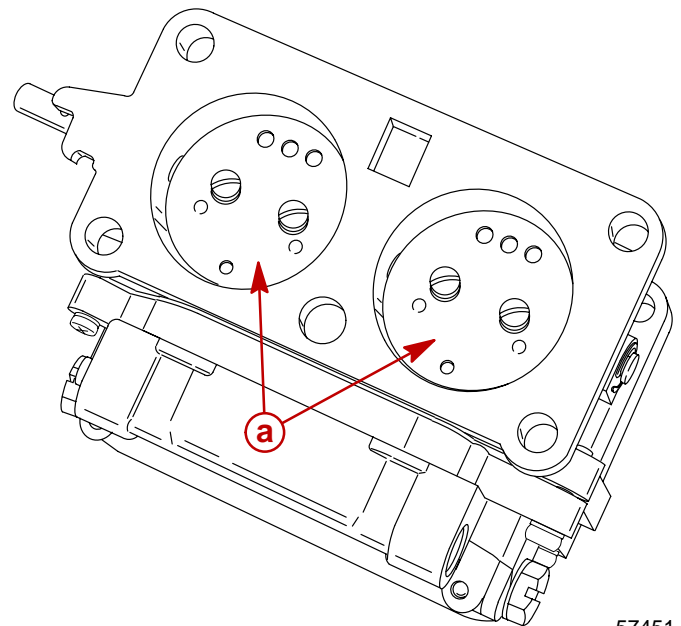

57451

a - Throttle Shutter (Install as Shown)
Figure 2.

C. FRONT COWL LATCH RETORQUE – 1989 MODEL V6 OUTBOARDS

Mercury Marine has recently received reports of front cowl latches coming loose on 1989 V6 Outboards due to insufficient torque on the top cowl bracket screws. (Figure 3) It is recommended that all 1989 V6 Outboards, when being serviced for any reason, have the top cowl bracket screws (Figure 3) torqued to 180 – 210 lb. in.

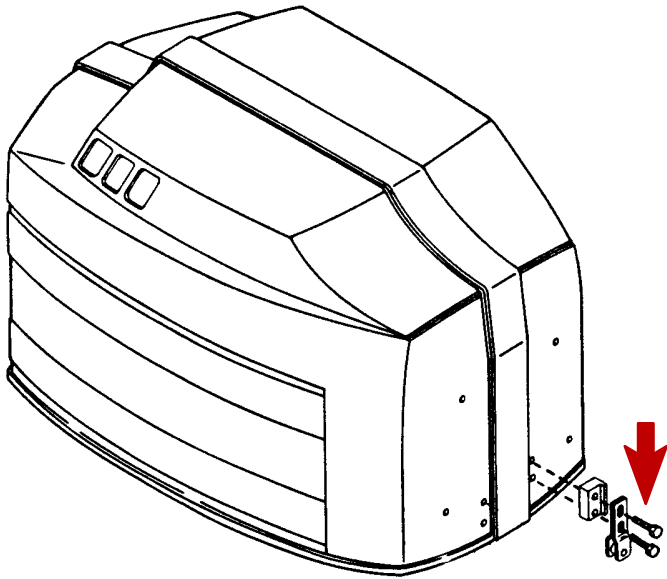

Figure 3.

D. OIL INJECTION PUMP IDENTIFICATION 3 CYL. MODELS 70-75-80-90 AND 4 CYL. MODELS 100-115

To identify the difference between the oil injection pump on the 3 cylinder and 4 cylinder outboards, the part number has been stamped on the lever as shown in Figure 4. P/N 42959 is stamped on the 3 cylinder oil injection pump lever and P/N 44345 on the 4 cylinder oil injection pump lever.

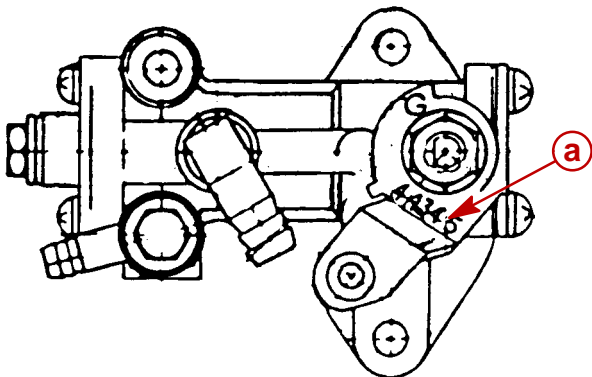

Figure 4.

a - Mark 44345

E. DRIVESHAFT BEARING RACE INSTALLATION – MODELS 35-40-50-60

Outboard Service Manuals P/N 90-42794 884 and 9086135 1287 refer to the driveshaft bearing race installation tool as 91-38918. This is not the correct tool. The correct tool should be 91-86290. Figure 5.

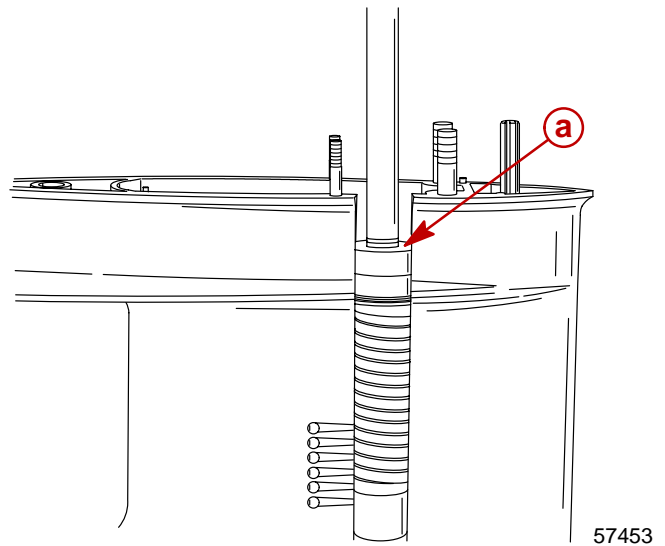

Figure 5. Installing Drive Shaft Bearing Race

a - Driver Cup 91-86290

F. TEST LEAD ASSEMBLY P/N 91-814746 V6 OUTBOARDS WITH E.F.I.

A test lead is now available to make the T.P.I. (Throttle Position Indicator) test more readily accessible. (Figure 6).

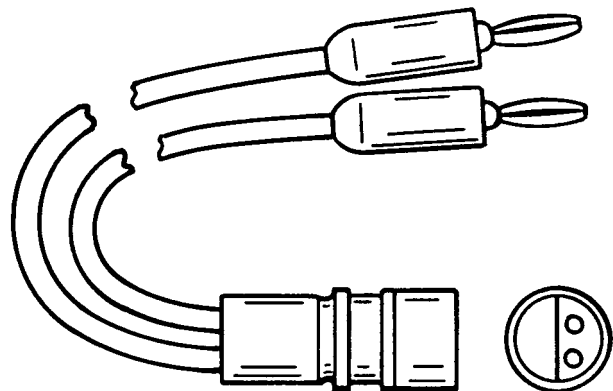

Figure 6. P/N 91-814746 T.P.I. Test Lead Assembly