

Shift Cam Follower Replacement - Mariner/Mercury 4/5 (102cc)

Shift cam follower P/N 16152 in gear housing on 1990 models listed may not have been properly hardened and must be replaced. Service replacement parts are not affected.

Every owner that registered one of the outboards listed prior to 10/20/89 will be sent a letter (copy attached) advising them to contact their authorized dealer. It is necessary to order a shift cam follower for all outboards listed that are in your inventory and were delivered.

MODELS:

U.S. Production Only – Does not affect Belgium Produced Models

Mariner 4M	S/N 0A858437–0A858536
Mariner 4M	S/N 0A860597–0A860616
Mariner 4ML	S/N 0A858537–0A858561
Mariner 5M	S/N 0A858762–0A858836
Mariner 5M	S/N 0A861152–0A861171
Mercury 4M	S/N 0A855447–0A855571
Mercury 5M	S/N 0A858562–0A858736
Mercury 5ML	S/N 0A858737–0A858761

PARTS REQUIRED:

Qty 1 P/N 16152 Shift Cam Follower

REPAIR PROCEDURE:

Disassembly – Drain gear lube, shift to either forward or neutral and remove propeller and attaching hardware. Remove two bolts securing rear housing to gear housing and remove rear housing, propshaft, reverse gear sliding clutch and shift cam follower as an assembly from gear housing (Figure 1). Discard original shift cam follower.

Assembly – Apply 2–4–C Marine Lubricant generously to shift cam follower and insert into propeller shaft. Inspect O–ring on rear housing and apply 2–4–C Marine Lubricant. Carefully install propeller shaft assembly into gear housing. Install rear housing bolts and torque to 70 lb. in. (8 N m). Fill gear housing with 6.6 fl. oz. (195 ml) gear lube, install propeller thrust hub, propeller and attaching hardware.

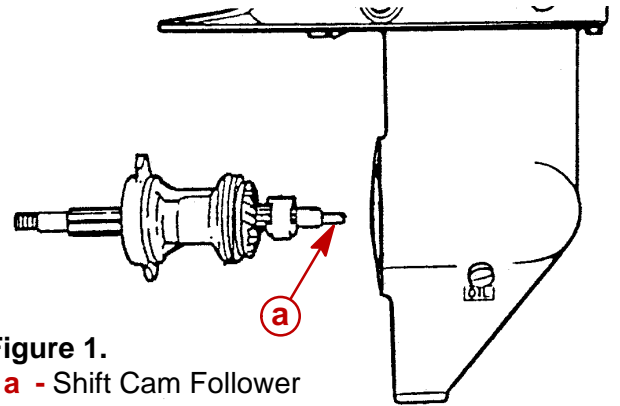

Figure 1.
a - Shift Cam Follower

REPAIR IDENTIFICATION:

Paint white dot above serial number on aluminum plug located on port side of powerhead. Outboards repaired at the factory will have serial plug marked with white dot and red round sticker applied to outside of shipping carton next to the serial number.

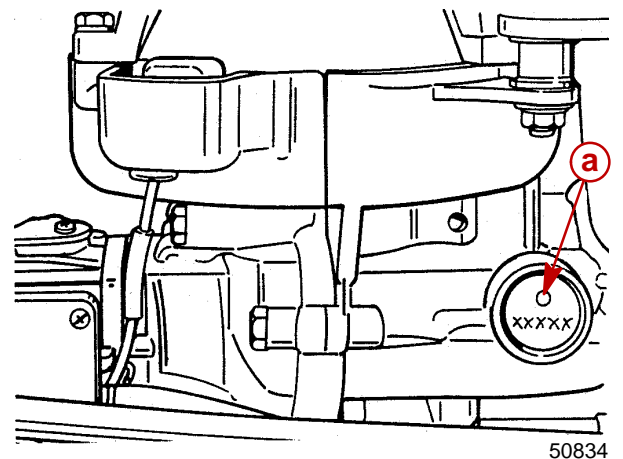

Figure 2.
a - White Dot Above Serial Number

WARRANTY:

Complete warranty claim listing:

Outboard serial number*
Qty 1 P/N 16152 Shift Cam Follower
One half (0.5) hour labor

*More than one outboard may be listed on a warranty claim; however, it is essential all serial numbers be listed.



Dear Mercury Owner:

Mercury Marine has determined that the 4 or 5 HP model you purchased may have an improperly hardened shift cam follower in the gear housing. If the shift cam follower is soft, your first indication is that the unit may not shift completely into reverse or may pop out of reverse.

Contact your authorized dealer for replacement of the shift cam follower. This service will be provided at no charge to you.

We regret the inconvenience this service may cause you, however, we have taken this action to ensure your boating enjoyment and continued satisfaction with our product.

Mercury Outboard Service Department