

Revised 3/29/99

GEARCASE FAILURES - 75 thru 125

NOTICE

This is a revision of Outboard Service Bulletin 96-17. Destroy existing Bulletin 96-17 and insert revised Bulletin 96-17.

Models Affected

MERCURY/MARINER

1995, 1996 and 1997 Mercury / Mariner 75 thru 125 HP Models, serial number
USA 0G077367 thru 0G589999
BELGIUM 9836633 thru 9973099

Some 1995, 1996 and 1997 model year outboard gear housings have experienced gear housing clutch failures. The failures reported are broken clutches and jumping out of gear.

CORRECTION

IMPORTANT: Inspect gear housing and components for impact damage, abuse, or modifications to gear housing. Failures caused by these conditions are not covered by warranty.

Broken Clutch - If the clutch is broken, the gear housing is probably badly damaged and replacement is necessary. Replace the gear housing assembly with a new 6-jaw clutch style gear housing assembly. Refer to the warranty section of this document for details on warranty coverage.

Jumping Out of Gear - If the unit will not stay in gear, the clutch dogs are probably rounded off. Inspect the clutch dogs for rounded edges. Rounded clutch dogs are caused by, but not limited to, improper shift cable adjustment, inadequate shift travel, idle rpm too high, and/or shifting too slow. **Rounded clutch dogs are not covered by warranty.**

A gearcase that has been jumping in and out of gear, may have caused the lower shift shaft pivot hole in the gear housing to elongate and not hold the shift cam in the proper position. Reassembly of that gear hous-

ing should NOT be attempted because the identical failure will be repeated in a short period of time. A visual inspection of the lower part of the lower shift shaft pivot hole in the gear housing is almost impossible. **Failure of a reassembled gear housing with an elongated lower shift shaft pivot hole will not be covered under warranty.**

GEAR HOUSING ASSEMBLY REPLACEMENT

IMPORTANT: Installation of a new 6-jaw clutch style gear housing assembly on non-tiller handle models involves powerhead removal.

Installation of a new 6-jaw clutch style gear housing assembly on non-tiller handle models will require the installation of a new upper shift shaft and shift link arm which involves powerhead removal. The new upper shift shaft, new link arm, and installation instructions are shipped with the gear housing assembly. The installation instructions will show by model which new shift part(s), if any, requires installation.

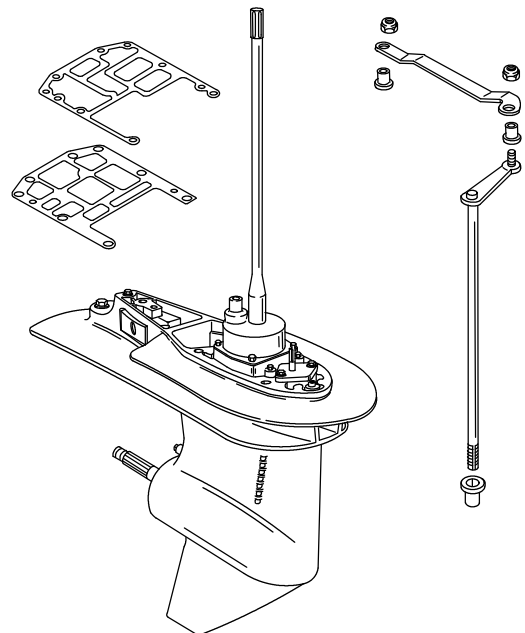

Replacement gear housing assembly components

Shift Cable Installation

Follow the latest throttle and shift cable adjustment recommendations to ensure gearcase durability.

1. Position the remote control and outboard into neutral.
2. Slide shift actuator (a) toward the rear of engine (reverse gear) until resistance is felt. Measure distance (b) between mounting stud (c) and barrel retainer (d).
3. Push the cable end (e) in (towards cable barrel) until resistance is felt. Adjust the cable barrel (f) to attain distance (b).

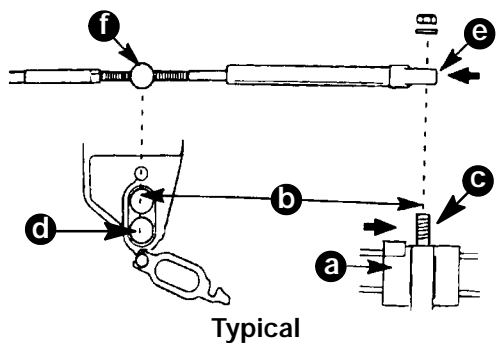

4. Place cable barrel (f) into retainer and close latch (i). Fasten the cable end to mounting stud with nylon washer (g) and locknut (h). Tighten locknut against the nylon washer, then back-off the locknut 1/4 turn.

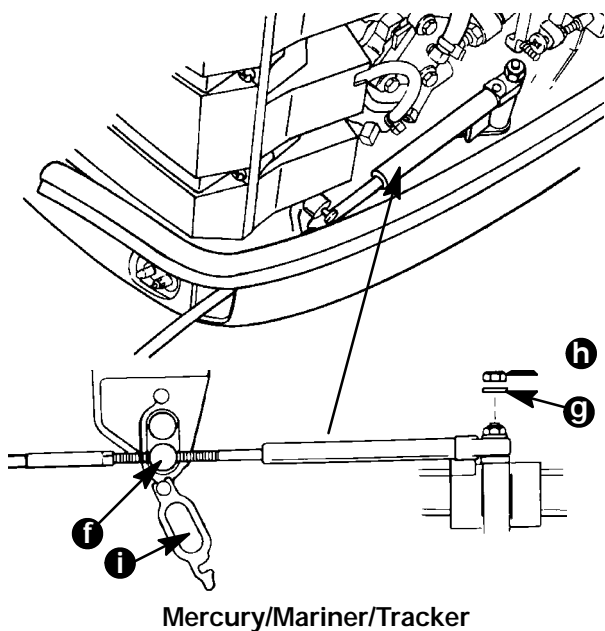

5. Instruct the customer on proper usage of warm-up lever / throttle only button on remote controls. Caution the customer not to shift above the maximum idle RPM specified in the Owner's Manual.

Recommendation

Commercial applications should use a propeller with a rubber hub to minimize stress and reduce the possibility of gearcase failures. Order Vengeance, High Five, or Laser II propellers with Flo-Torq I rubber hubs by replacing the "A45" part number suffix with an "A40" suffix.

Gear Housing Assembly Identification

⚠ CAUTION

Identify gear case design to ensure correct components are being installed. Design I - "3 Jaw Reverse Clutch" (a) gear case identified with straight machined edge for trim tab screw mounting surface. Design II - "6 Jaw Reverse Clutch" (b) gear case identified with angled machined edge for trim tab screw mounting surface.

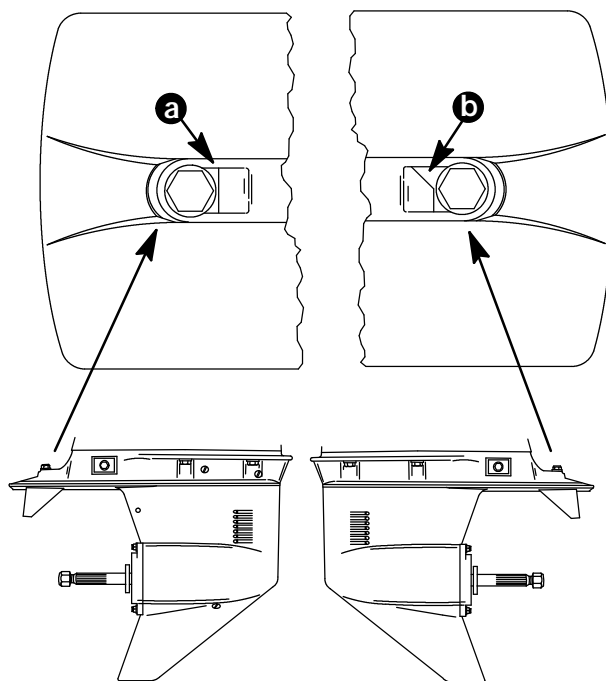

1987 - 1997 1998 and Newer
"3 Jaw Reverse Clutch" "6 Jaw Reverse Clutch"

a - Design I - "3 Jaw Reverse Clutch" Gear Case Identifier
b - Design II - "6 Jaw Reverse Clutch" Gear Case Identifier

After the "6-Jaw Reverse Clutch" gear housing and updated Shift Shaft have been installed replacement parts **MUST** be ordered from the "6-Jaw" section of a 1998 model year and newer parts list. "3-Jaw" and "6-Jaw" reverse clutch parts are **NOT** interchangeable.

Component Application for Design II "6-Jaw Reverse Clutch" Gear Housing Replacement

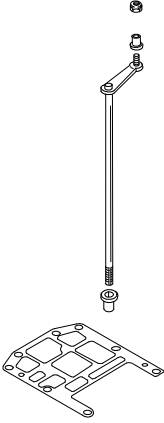
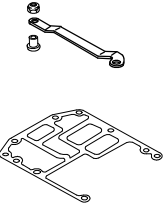
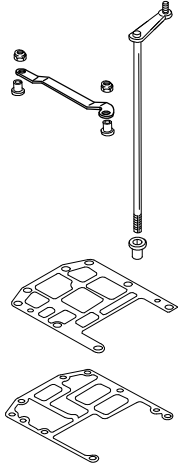
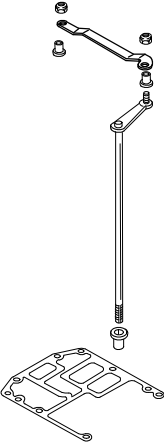
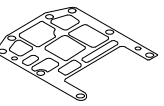
Models	Installation Required	Not Required
Force/Force Tracker 90 ELPT 90 EXLPT 120 ELPT 120 EXLPT		
Mercury Tracker 75 ELHPTO		
Mercury Tracker 75 ELPTO 90 ELPTO 115 ELPTO 125 ELPTO		

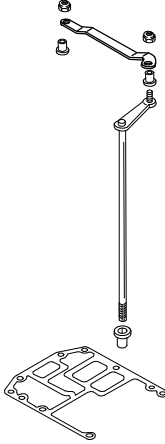
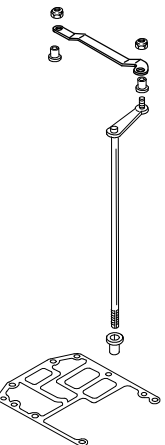
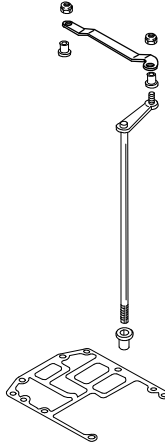
Models	Installation Required	Not Required
SeaPro/Marathon 75 MLH 75 MLLH 75 ELH 75 ELLH		
Mercury/Mariner 75 ELHPTO 90 ELH 90 ELLH 90 ELHPTO 100 EXLHPTO		
Mercury/Mariner 75 ELO 75 ELPTO 90 EL 90 ELPTO 100 ELPTO 115 ELPTO 115 EXLPTO 125 ELPTO 125 EXLPTO		

Parts Required

75 / 90 GEAR HOUSING ASSEMBLY

P/N	Description
1667-9011G33	Long-Black
1667-9011G34	X-Long-Black
1667-9011G35	LL-Black
1667-9011G36	Long-Gray
1667-9011G37	X-Long-Gray
1667-9011G38	LL-Gray
1667-9011G25	Tracker-Graphite Gray

100 THRU 125 GEAR HOUSING ASSY. 2.07:1 GEAR RATIO

P/N	Description
1667-9011G39	Long-Black
1667-9011G40	X-Long-Black
1667-9011G41	Long-Gray
1667-9011G42	X-Long-Gray

100 THRU 125 GEAR HOUSING ASSY. 2.3:1 GEAR RATIO - (HIGH ALTITUDE)

P/N	Description
1667-9011G33	Long-Black
1667-9011G34	X-Long-Black
1667-9011G35	LL-Black
1667-9011G36	Long-Gray
1667-9011G37	X-Long-Gray
1667-9011G38	LL-Gray
1667-9011G25	Tracker-Graphite Gray

Warranty

Gear housing failures will be covered for a period of two (2) years from date of sale to the original owner to assure customer satisfaction. U.S. and Canadian dealers are to call Outboard Technical Service for warranty pre-authorization or complete and send a QuickFax form (p/n 90-821655) to have a complete gearhousing assembly and a pre-printed warranty claim sent to them.

Complete a warranty claim listing:

- Outboard Serial Number
- Qty 1 p/n 1667-XXXXXXX Gear Housing
- Flat Rate Codes
Gear Housing replacement
 - 0G12 R&R Gear Housing 0.7 hours
 - 0G20 Diagnose and test 0.3 hoursShift Shaft replacement (if required)
 - 0D32 Shift Rod Upper 1.5 hours
- Failure code: 204 00

U.S. and Canada dealers: Return gearhousing assembly with warranty claim.

International: Hold gearhousing assembly for inspection/disposition by Marine Power International Technical Representative.