

## Autoblend/Autoblend II Maintenance

### PROBLEM:

Customers with outboard engines utilizing the Autoblend/Autoblend II oil injection system may experience water accumulation in their oil reservoirs. It has been determined that the leading cause of this problem is condensation. If this water is allowed to accumulate to an appreciable level, it can eventually enter the oil pick up and subsequent engine damage can occur.

### INSPECTION:

It is recommended that the oil reservoir be inspected for water accumulation in late spring/early summer and in late fall/prior the storage as normal maintenance. To do this, allow the engine/reservoir to set overnight so that any water that is present will settle out. Tip the reservoir on one of the bottom corners. Locate a 12 in. (305 mm) long section of clear tubing and place a finger over one end of the tube. Insert the other end in the lowest corner of the reservoir. Release the finger, allowing water/oil to enter the tube. Place the finger back over the end, withdraw the tube, and immediately place another finger over the bottom end of the tube. Visually check for water in the tube. If water is present, the reservoir must be drained and thoroughly cleaned.

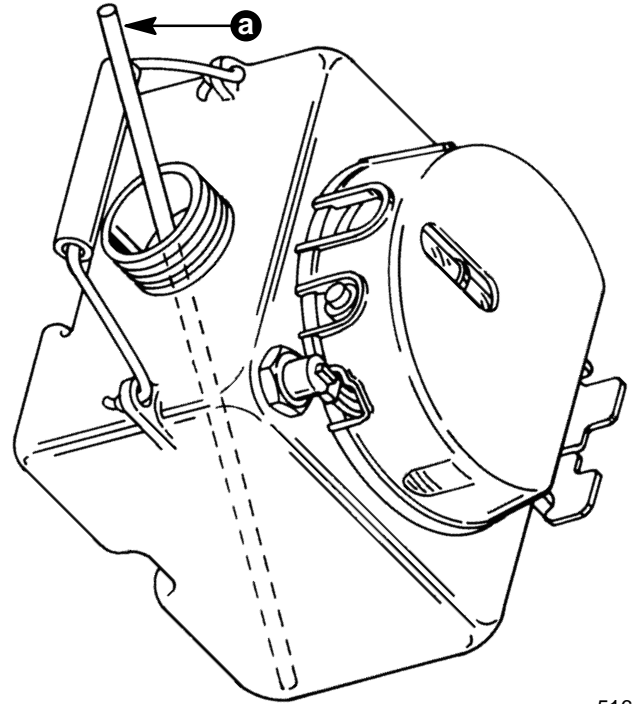

51635

a - Clear Tubing, 12 in. long (305 mm)

## **CORRECTION:**

To minimize water accumulation in the reservoir:

1. Keep reservoir topped off with oil whenever possible.
2. Mount in a location that is out of direct sunlight and water spray.

## **MAINTENANCE RECOMMENDATIONS:**

### **After Each Refilling:**

1. Check that Autoblend fill cap is tight.
2. Check low oil warning horn system by turning Autoblend tank upside-down. This will allow the float to activate the horn. If horn does not sound, check in-line fuse (Autoblend I only) or 9 volt battery power level using battery test button (Autoblend II only).
3. Check that Autoblend is securely mounted in bracket.

### **Monthly:**

1. Check fuel filter for any sediment. Replace as necessary.
2. Check that fuel lines are free of stress and kinks and that hose clamps are tight.

### **Twice a Year:**

Inspect for water accumulation in late spring/early summer and in late fall/prior to storage.

### **Before Storing Autoblend:**

1. Drain fuel from diaphragm area.
2. Top off Autoblend reservoir with oil.

## **Bringing Autoblend Out of Storage**

Have Autoblend diaphragm inspected at beginning of each season by an authorized dealer.

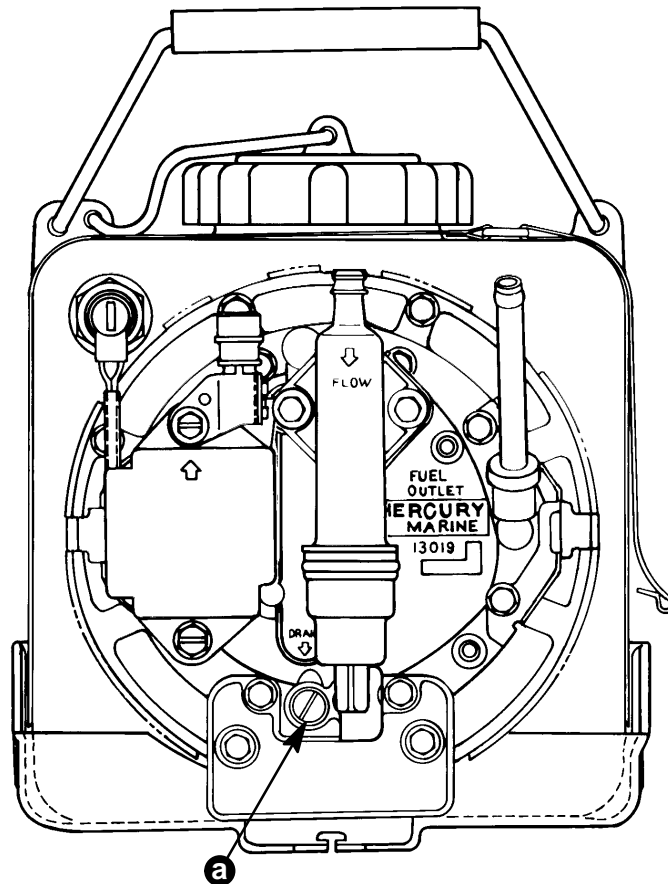

a - Fuel Drain Screw