

Galvanic Corrosion – 250/275

**Mariner and Mercury
1989 and Newer 250 and 275
S/N 0C101891 and above**

The trim tab P/N 17264T on the 250/275 models is made of XK360 aluminum alloy and its function is to offset steering torque. This trim tab does not function as a sacrificial anode. The sacrificial anode used to help prevent galvanic corrosion is mounted on the bottom of the transom brackets and must be submerged to be effective. Some boats may not allow the transom bracket anode to be below the water when the boat is stationary. When the anode is out of the water, the outboard is without galvanic protection. This may happen more often with the taller 30 inch (762 mm) XX-long models.

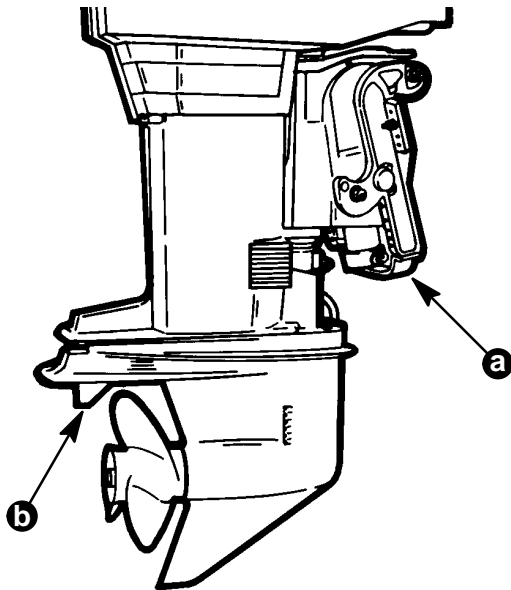

24502

a - Transom Bracket Mounted Anode
b - Trim Tab

If the transom bracket anode is not submerged when the boat is stationary, the outboard requires galvanic protection. Install:

- a MerCathode system P/N 88334A-2
- or -
- an anode Kit P/N 71320A-3. Note: long wire supplied with the kit is not required on the 250/275 models with a ground strap around the lower rubber mounts.