

Gearhousing Exchange Program – 150 thru 200

Models Affected

MARINER AND MERCURY

2.5 Litre

150, 175, 200 Models

USA AND CANADA ONLY

Outboards operated at a high transom mounting height may experience gear, bearing, bearing carrier, and propshaft failures. Mounting height limits for standard gear housings on the models listed must not be exceeded to assure both performance and durability.

A gearhousing assembly exchange program is established to help dealers and customers obtain the Hi-Performance gearhousing assembly required for higher than standard transom mounting height use. This bulletin provides gearhousing recommendations with advantages, disadvantages and application cautions for each type of gearhousing assembly. The program applies to new, unused gearhousing assemblies only.

Warranty

Gear, bearing, bearing carrier, and propshaft failures on standard gear housings used above the recommended mounting height limits will not be considered for warranty.

Failures on standard gearcases modified with nose cones and low water pickups will not be considered for warranty.

Recommended Outboard Mounting Height

NOTE: Add 5 inches (125 mm) to the following requirements for XL models.

Standard Gearhousing Assemblies for long shaft 20 inch (508 mm) models are acceptable for use at transom mounting heights up to 25 inches (635 mm).

Standard Gearhousing Assembly

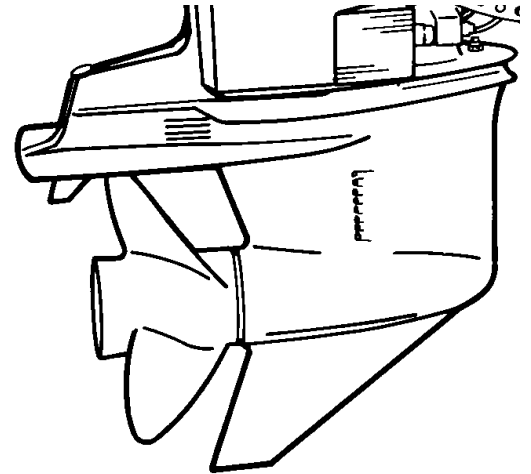

Advantages

1. Large amount of water inlet area which reduces low water inlet velocity at idle and results in very little weed ingestion.
2. Excellent hydrodynamic design for installations below 25 inches. Actually faster than high performance gear cases at 25 inches and below.
3. Blow out speed in the low 80 MPH range (depending on the boat and amount of trim angle required to achieve the desired bow lift).
4. Good exhaust flow through the bearing carrier which keeps the exhaust back pressure low.

Disadvantages

1. Above 25 inches the upper water inlets may start sucking air which reduces water flow.
2. Above 25 inches the bearing carrier, the two piece prop shaft, or the prop shaft roller bearing may become over-stressed and fail because of the high loads generated by a highly surfaced propeller.

Mercury Hi-Performance Torque Master Gearhousing Assembly

These assemblies are recommended for use at mounting heights of 25 inches (635 mm) to 27 inches (685 mm). Particularly effective on boats that require a fair amount of positive trim to lift the bow.

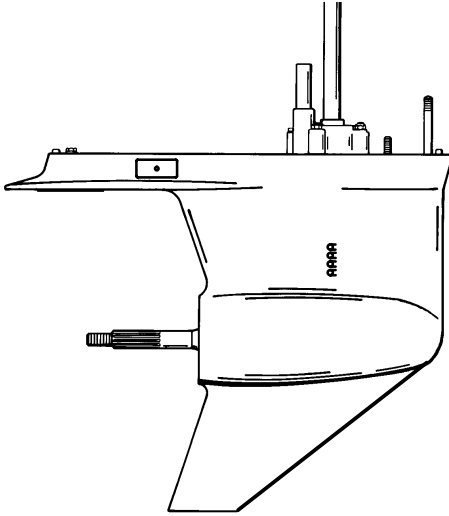

28384

Advantages

1. Has only the 4 lower water inlets on the strut to allow for higher installations without sucking air.
2. Cast in torque tab on skog to counteract steering torque when using right hand rotation propellers.
3. Uses all of the high performance internal components (refer to Internal Components following) for extra strength and durability.
4. The drain/fill plug is removed from the front of the torpedo and relocated in the bearing carrier. This eliminates a source of cavitation formation at higher speeds.
5. Provides a slightly higher blow out speed than the standard production case because it will run with less "crab" angle and the relocation of the oil drain/fill plug. This will depend on the boat and the amount of trim angle required to achieve the desired bow lift.

Disadvantages

1. May be prone to a little more weed ingestion at idle because of less inlet area (higher water inlet velocity).
2. Mounted below 25 inches, the torque master may be slower than the production gearcase because of an increase in hydrodynamic drag.

3. Has a little more exhaust restriction because of heavy duty bearing carrier resulting in a little less developed horsepower.

Mercury Hi-Performance CLE Gearhousing Assembly

These assemblies are recommended for use at mounting heights of 27 inches (685 mm) to 30 inches (760 mm). Particularly effective on boats that require little to no positive trim to achieve maximum speed. This means that the boat must have a great amount of hydrodynamic and/or aerodynamic lift designed into the boat bottom and deck.

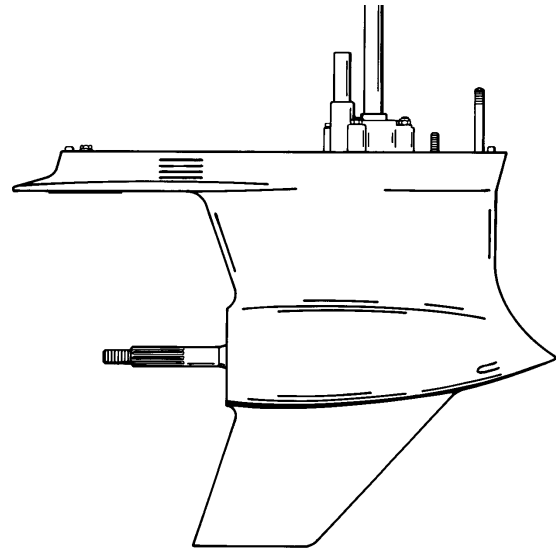

28382

Advantages

1. Below-the-torpedo water inlets allow for these extremely high installations.
2. High performance internal components for extra strength (refer to Internal Components following).
3. Very high blow out speeds (mid 90 MPH on V-bottoms to 100+ MPH on some air entrapment type hulls).
4. Cast in torque tab to compensate for steering torque with right hand rotation props. Torque tab is removed on counter rotation units.
5. When set up ideally the pointed nose of the torpedo will be at the water surface and provides the least amount of hydrodynamic drag of all of these gearcases.

Disadvantages

1. Has the same exhaust restriction as the torque master because of the heavy duty bearing carrier resulting in a little less developed horsepower than the standard gearcase.
2. More prone to weed ingestion at idle because of smaller water inlet area and high inlet water velocity. Although, the 4 hole CLE inlet is the best compromise between weed ingestion and speed.
3. Very slow gear case running sub-surface because of the increase in hydrodynamic drag.
4. Running too deep may also cause the torque tab to over compensate for the lack of propeller torque and cause ill handling.
5. Does not react well to boats requiring a high degree of positive trim to achieve desired bow lift.

NOTE: See pages 49 & 50 of "Everything You Should Know About Propellers – Fourth Edition" for a full explanation of "Blow-Out".

WARNING

Loss of boat control at high speed can result in serious injury or death. Testing for blow-out should be done by a highly experienced and competent driver. Certain boats (especially V-Bottoms) may react violently to a high speed blow-out. An experienced driver can usually feel a blowout starting to occur before the boat loses lift and veers to one side. Never perform blow-out testing with passengers. Always wear high quality, high performance life jacket. Always have a safety boat present. Read the lanyard stop switch information in the operation and maintenance manual before electing to install, use, or not to use such a switch.

Hi-Performance Internal Components

Combined with the cast-in torque tab, moving the oil fill screw, redesigning and relocating the water inlets, some internal components are also different from the standard gearhousing assemblies. These differences allow operation at higher transom heights.

Bearing Carrier – Thicker and stronger casting.

Bearing Carrier Retaining Nut – Thicker and stronger.

Bearing Carrier Bearings – Larger for increased durability.

Propeller Shaft – Larger one piece carbon steel chrome plated for increased strength.

Drive Shaft – One piece carbon steel chrome plated for increased strength.

Clutch Cross Pin – Threaded for increased retention.

Gearhousing Assembly Exchange Program

USA

Order the correct Hi-Performance gearhousing assembly and propeller thru Technical Service on a Pre-Authorized Warranty Claim by engine serial number. The Pre-Authorized Warranty documents the exchange for record purposes.

CANADA

Order the correct Hi-Performance gearhousing assembly and propeller thru the Mississauga Parts Department at (905) 270-4481. Also request an "Authorization to Return" form.

Install the Hi-Performance gearhousing assembly and propeller per the Service Manual.

Return – Carefully pack and return the unused gearhousing assembly and unused propeller to:

USA

with signed Pre-Authorized Warranty Claim.

MERCURY MARINE
WARRANTY RECEIVING
W6250 W. PIONEER RD.
FOND DU LAC, WI 54936-1939

CANADA

with signed Return Authorization form.

MERCURY MARINE
1156 DUNDAS STREET EAST
MISSISSAUGA, ONT. L4Y2C2
ATTN: PARTS DEPARTMENT

Mark the box "GEARHOUSING ASSEMBLY EXCHANGE PROGRAM".

Costs and Credits

Dealer is billed for the Hi-Performance gearhousing assembly and propeller at Dealer Cost.

Dealer is credited for unused, undamaged standard gearhousing assembly and propeller at Dealer Cost.

Dealer charges Customer for the gearhousing assembly and propeller price difference, plus mark-up, shipping and labor.

Hi-Performance Gearhousing Assembly Part Numbers

TORQUE MASTER GEARHOUSING ASSEMBLIES

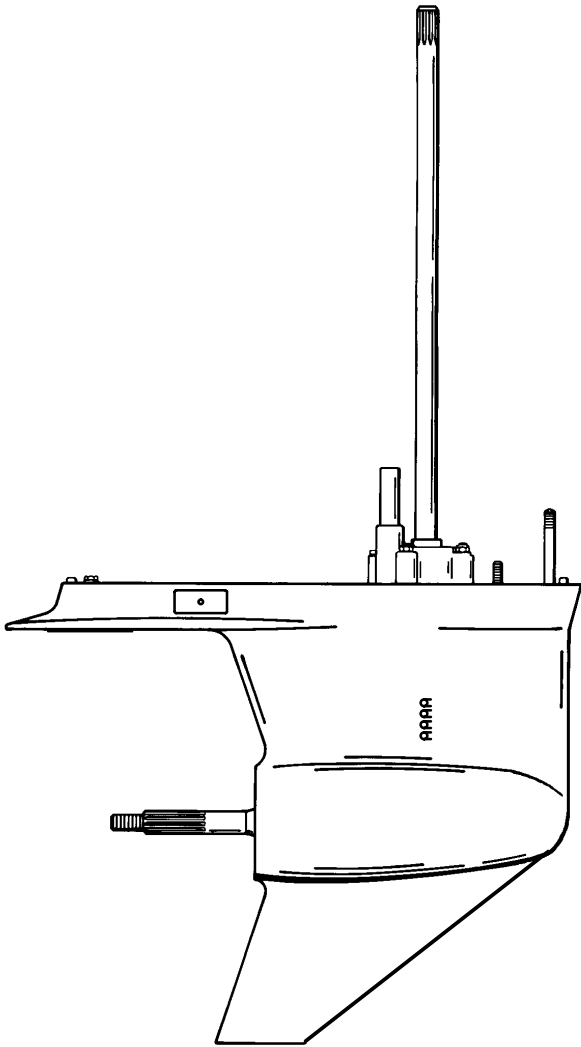

20 Inch 1.87:1 Ratio
1686-827214A-3 Black RH
1686-827214A-4 Gray RH

28384

CLE GEARHOUSING ASSEMBLIES – FULL SKEG

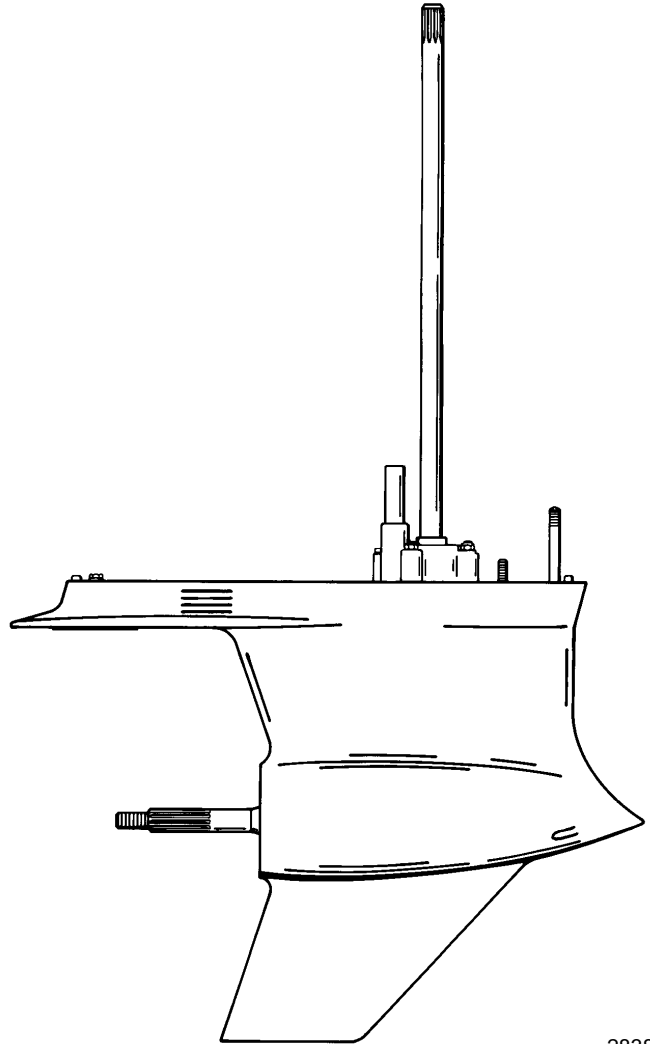

28382

20 Inch – 1.87:1 – Full Skeg
1685-847902A-5 Black RH
1685-847902A11 Gray RH
25 Inch – 1.87:1 – Full Skeg
1685-847902A-7 Black RH
1685-847902A13 Gray RH

CLE GEARHOUSING ASSEMBLIES – CUT SKEG

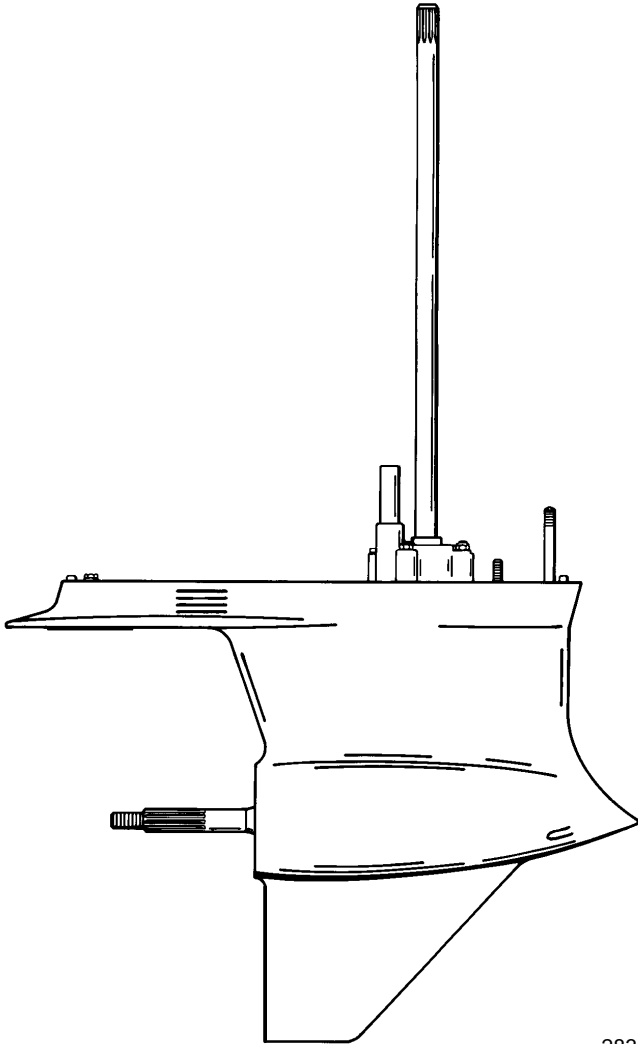

28383

20 Inch – 1.87:1 – Cut Skeg
1685-847903A-5 Black RH
1685-847903A17 Black LH
1685-847903A11 Gray RH
1685-847903A23 Gray LH

25 Inch – 1.87:1 – Cut Skeg
1685-847903A-7 Black RH
1685-847903A19 Black LH
1685-847903A13 Gray RH
1685-847903A25 Gray LH