

## Starter Motor P/N 50-818445 3

### Models Affected

#### MERCURY/MARINER

1998 225/250 HP, 3.0 Litre  
S/N OG594077 Thru OG638551

The rubber snubbers inside the starter motor housing may have been dislodged, during assembly. Lack of the correct snubber will allow the starter motor through bolts to vibrate excessively causing breakage of the bolts.

### Inspection/Correction

When engine is in for service, or before sale of the engine, inspect engine carton, or starter motor for having been reworked at the factory. Rework identification listed below. If engine has NOT been reworked at the factory, replace the starter motor .

### Repair Identification

**FACTORY IDENTIFICATION:** Engines reworked at the factory will have a Blue dot marked on the engine carton near the serial number location, and the white letters "OK" marked on the starter motor near the part number label.

**DEALER IDENTIFICATION:** After having replaced the starter motor, mark with white paint near the starter motor part number label the letters "OK".

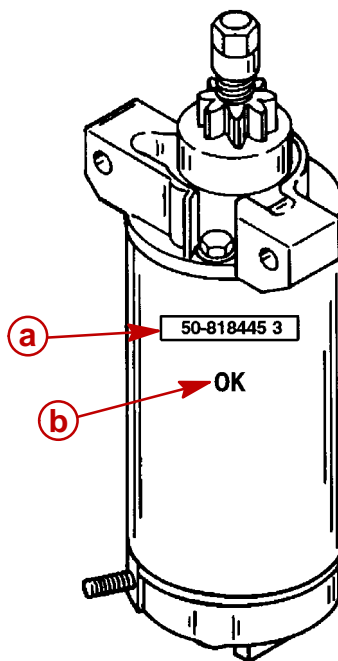

a - Starter Motor Part Number Label  
b - Factory Rework Marking (OK)

---

## Dealer Stock

Starter motors P/N 50-818445 3 with date codes between 03/17/97 and 08/01/97 without the white letters "OK" marked on the starter, should be sent back for credit. The date code is located on the starter motor part number label.

## Parts Required

Qty. 1 **P/N 50 - 818445 3**

**NOTE:** When current inventory of **P/N 50-818445 3** starters are depleted, it will supersede to **P/N 50-818445 5**.

## Warranty

Starter motor replacement due to broken through bolts, or incorrect snubbers, within the above listed serial number range, will be covered by special warranty for two (2) years from the original date of sale. Do not submit a warranty claim for inspection of factory rework markings only.

Complete a warranty claim listing:

- Outboard serial number
- Quantity 1 P/N 50-818445 3
- One (1.0) hour labor (starter motor replacement only)
- Flat rate code NJC
- Failure code 321-00

US & CANADA- Complete/process claim and return starter motor with warranty claim form.

INTERNATIONAL- Hold parts for inspection/disposal by a Marine Power International technical representative.