



# service bulletin

No. 98-8

## 135/150 Optimax Update

### Models Affected

MERCURY/MARINER  
S/N 0G636539 Thru S/N 0G760299

Listed are items to be updated on early production 135/150 HP, Optimax/DFI outboards. Improvements are being offered to current owners and are to be made on outboards in dealer inventory to provide improved reliability, durability and performance. The updated items listed have been implemented on production outboards as running changes.

### Owner Notification – USA/Canada

A letter will be sent to every registered owner of an affected outboard. The letter will advise the owner to return their outboard to their selling dealer or any Mercury/Mariner authorized dealer for the updates, listed on this bulletin and previous Service Bulletin 98-3. Some engines may have already had the updates listed on Service Bulletin 98-3 performed. Please refer to Bulletin 98-3 for identification of these updates, or check engine history using the Midas system. A copy of the letter is included with this Service Bulletin. Note: Customer letters were not sent as mentioned on Service Bulletin 98-3 due to parts shortages. Sufficient parts are now in stock to complete both updates.

### Dealer Outboard Inventory

Affected outboards in dealer inventory **MUST BE** updated prior to customer delivery.

#### ITEM # 1 FLYWHEEL COVER – S/N 0G636539 THRU S/N 0G654821

Replace flywheel cover with new flywheel cover **P/N 827325A7** with improved fuel hose retainer.

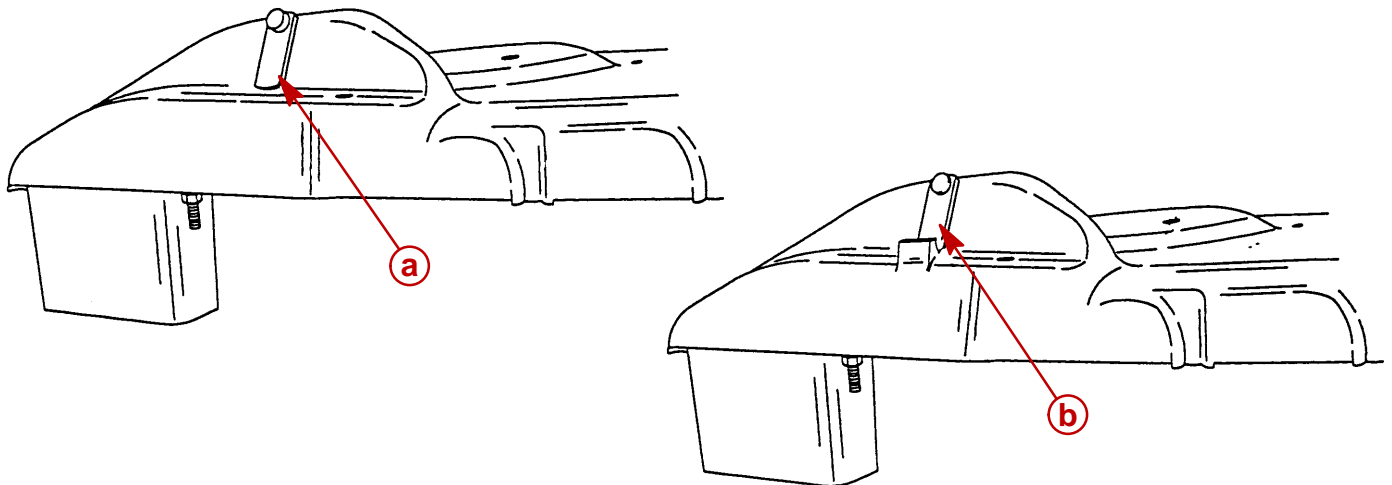

- a** - Old Style Retainer
- b** - New Style Retainer

**ITEM # 2 FUEL HOSE & PUMP UPGRADE – S/N 0G636539 THRU S/N 0G742514**

Several fuel hose and pump changes have been made to improve fuel hose clearance, routing, and pump durability. Install upgrade kit **P/N 803025A1**, all parts and instruction sheet are included in kit.

**NOTE:** To crimp metal fuel system clamps, use Mercury special tool **P/N 91-803146T**, Snap-On tool **P/N YA3080**, or equivalent.

**ITEM # 3 BELT TENSIONER ARM – S/N 0G636539 THRU S/N 0G760299**

Install new tensioner arm that has improved center support bushing and additional grease fitting. Order arm kit **P/N 856815A3** which includes tensioner arm, center support bushing, mounting stud, and installation instructions.

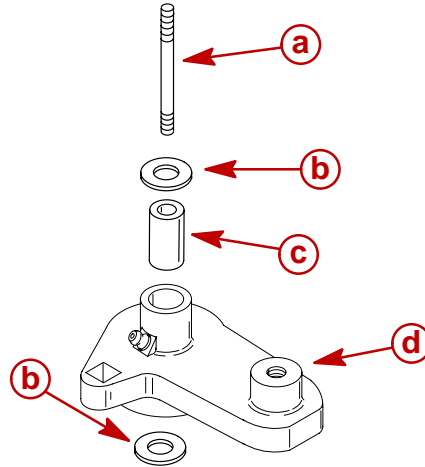

- a** - Stud, (P/N 16-856900)
- b** - Flat Washer, (2) (P/N 12-40023-20)
- c** - Bushing (P/N 23-856894)
- d** - Tensioner Arm (P/N 856815A2)

**ITEM # 4 ALTERNATOR BRACKET – S/N 0G636539 THRU S/N 0G760299**

Install new rubber mounted brackets that will help isolate the alternator from vibration.

Bracket kit **P/N 856974A1** includes brackets, rubber mounts, mounting hardware, and installation instructions.

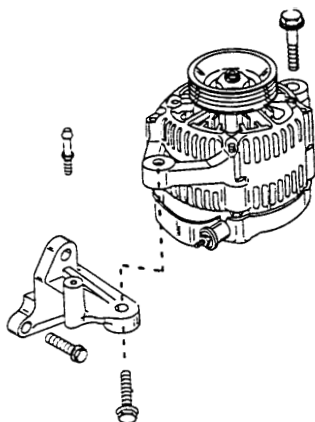
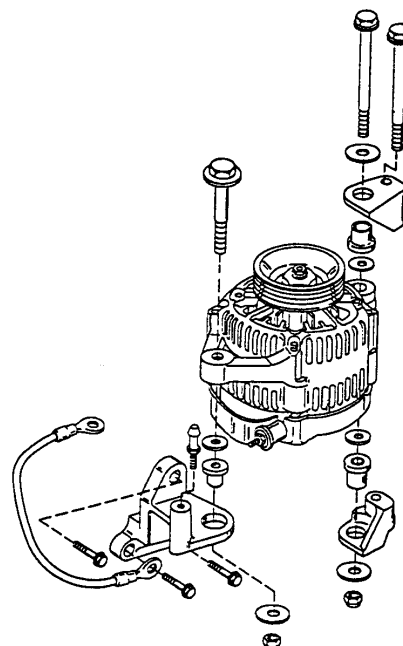
**Solid Mount****Rubber Mount****ITEM # 5 LOOSE BATTERY CABLES – S/N 0G636539 THRU 0G760299**

Loose battery cables, can cause false fail codes and running problems. Check for loose or corroded connections. There have been reports of the negative cable retainer bolt bottoming out in the threaded hole before sufficient battery cable clamp load is obtained. If battery cable can be rotated by hand, install flat stainless steel washer **P/N 12-814806** between battery cable and lower starter motor end cap.

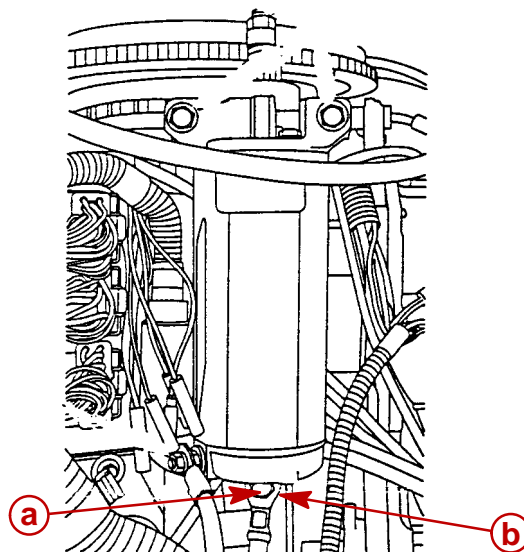
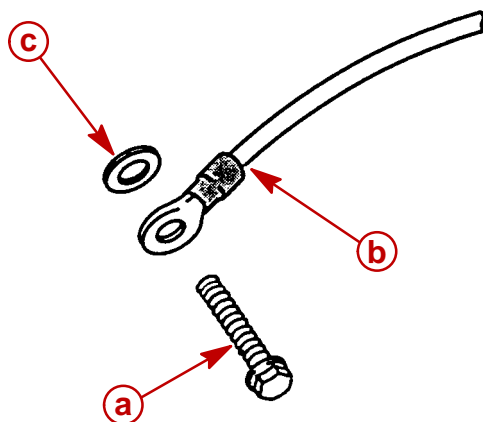

- a** - Bottom starter mounting bolt [torque 21 lb. ft. (28.5 N-m)]
- b** - Negative battery cable
- c** - Washer (P/N 12-814806) - Place between starter end cap and negative cable

## Update Group Chart

Use the following serial number group chart, to help determine which items need to be updated on the engine being serviced.

Group # 1	0G636539 thru 0G654821	Items 1, 2, 3, 4, 5
Group # 2	0G654822 thru 0G742514	Items 2, 3, 4, 5
Group # 3	0G742515 thru 0G760299	Items 3, 4, 5

## Parts Required

Item # 1 Flywheel cover (Qty. 1)	<b>P/N 827325A7</b>
Item # 2 Fuel hose and pump kit (Qty. 1)	<b>P/N 803025A1</b>
Item # 3 Belt tensioner kit (Qty. 1)	<b>P/N 856815A3</b>
Item # 4 Alternator bracket kit (Qty. 1)	<b>P/N 856974A1</b>
Item # 5 Washer battery cable (Qty. 1)	<b>P/N 12-814806</b>

## Warranty

The normal Optimax warranty applies, when performing all items listed.

- Complete warranty claim listing
- Outboard serial number
- Parts as required
- Determine labor time per chart - enter total as applicable
- Flat rate code NJC
- Failure code 305-00

<b>Labor Time Chart</b>	
Time for testing and adjusting is included	
Item # 1	0.2 hours
Item # 2	1.1 hours
Item # 3	0.7 hours
Item # 4	0.7 hours
Item # 5	0.2 hours

US & Canada: Complete/process claim via Midas or return a warranty claim form. Return the low pressure and pulse fuel pump assemblies with warranty claim. All other parts tag and hold for 60 days after credit is received.

INTERNATIONAL: Follow instructions issued by Marine Power International office or by your distributor.



W6250 PIONEER ROAD  
P.O. BOX 1939  
FOND DU LAC, WI 54936-1939 U.S.A.

PHONE (920) 929-5000 ■ FAX (920) 929-5060

Dear Optimax Owner

Congratulations on your decision to purchase a new Optimax, the most technologically advanced outboard ever designed.

Through continuing research, we have developed advanced components that will make your engine even more durable and dependable. To ensure your continued satisfaction, we would like to have them installed on your engine. Your dealer can explain about the work that will be done.

Please contact your dealer to make arrangements to have this service performed at a time mutually convenient for both of you.

### **What You Should Do**

First contact your authorized dealer, preferably the one who sold you the outboard and make an appointment to have your engine serviced per Service Bulletin 98-3 and 98-8. Then, deliver your boat to your dealer at the appointed time. The reverse side of this letter comprises a claim form that the dealer will send to us for reimbursement, so please give it to the dealer.

We apologize for any inconvenience, but the benefits of having these improvements incorporated into your engine are significant. You are a valued customer, and we want to do everything possible to enhance the quality of your boating experience. Thanks for this chance to serve you.