



service information

ADVISORY
 BULLETIN

No. 99-5

Circulate to: Sales Manager Accounting Service Manager Technician Parts Manager

Fuel Starvation

NOTICE

This is a revision of Outboard Advisory 99-5. Destroy original Advisory 99-5 April 1999 and insert revised Advisory 99-5 January 2000.

Models Affected

MERCURY/MARINER

1987 and later, 30 Thru 250 HP, (with square fuel pump)

FORCE

1994-1/2 and later 40 Thru 120 HP, 1997 and later 175 Sport Jet

It is important that fuel supply restrictions/vacuum levels do not exceed specification. High restrictions may result in the engine stalling at low speed, and/or a lean fuel condition at high RPM, that could cause non-warrantable engine damage. It is recommended to check fuel system vacuum on all new boats/engines being prepared for delivery to ensure customer satisfaction and engine durability.

Inspection/Test

Fuel system vacuum can be checked using a short piece of extra fuel hose, vacuum gauge, and a "TEE" fitting.

- Remove pulse pump inlet hose.
- Connect extra hose to pulse pump.
- Connect "TEE" fitting to extra hose.
- Connect vacuum gauge to "TEE" fitting.
- Reconnect fuel inlet hose to "TEE" fitting.

Make the T-fitting connection as close to the fuel pump as possible.

Before proceeding with the system vacuum test confirm that the pulse fuel pump is capable of supplying the required vacuum. To do this, start the engine, pinch off/restrict the fuel supply hose between the vacuum gauge and fuel tank. The vacuum gauge should rise to or exceed the maximum normal reading of 2.5 inches vacuum (mercury). If it fails to reach this minimum number the pump needs servicing or there is a lack of crankcase pressure to operate the pump.

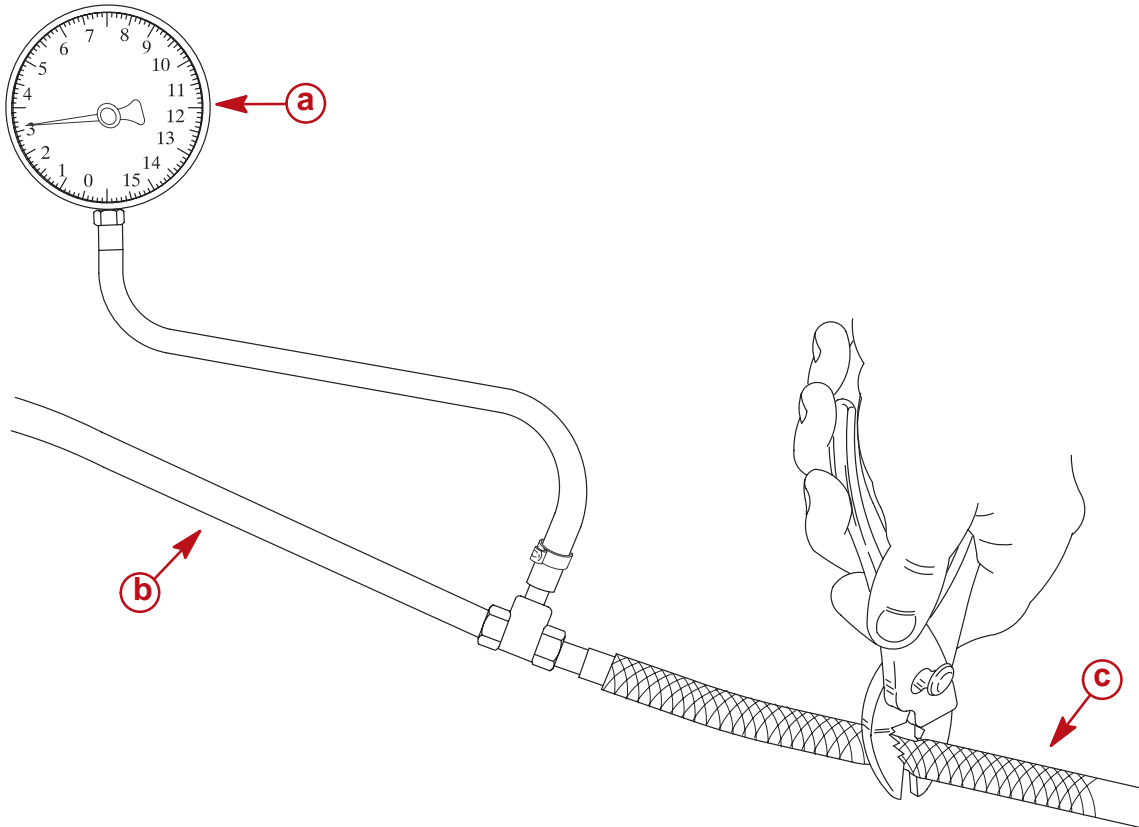

57859

- a** - Vacuum Gauge
- b** - Extra Fuel Hose Connected to Pump
- c** - Fuel Supply Hose from Tank

The system vacuum test is normally performed at an idle speed. As engine RPM increase, there will be a slight increase in vacuum; this increase should not exceed normal readings at any RPM.

Normal Reading	➔	Below 2.5 in. of vacuum (mercury)
Reading above 2.5 in. of vacuum (mercury)	➔	Restriction within the fuel system <ul style="list-style-type: none"> • Restricted anti-siphon valve • Restricted or malfunctioning primer bulb • Kinked or collapsed fuel hose • Plugged water separating fuel filter (in the boat) • Restriction in fuel line thru-hull fitting • Restriction in fuel tank switching valves • Plugged fuel tank pick-up screen

If system vacuum reading is less than 2.5 in. and the engine continues to stall at low speed, the following two up-upgrades to the fuel system may help resolve this condition.

PULSE FUEL PUMP:

The new repair kits contain check valves made of a plastic material, impervious to damage from additives. When repairing the fuel pump discard old rubber and small plastic check valve disks, and install one new plastic disk under each retainer. Caution must be taken not to push the check valve retainer to tightly against the check valve, this may cause valve to deform.

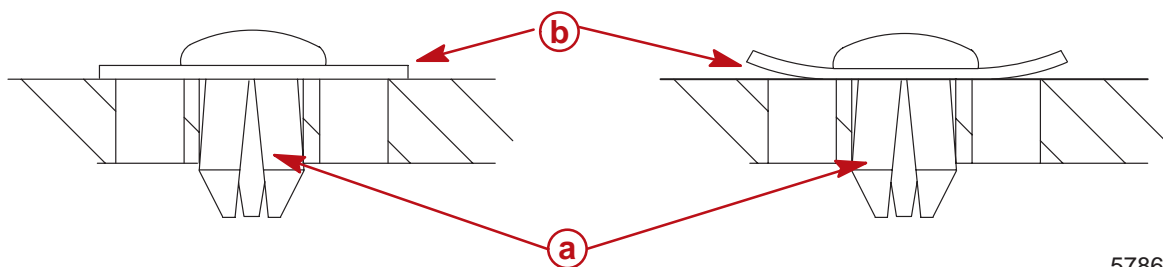

57861

CORRECT

INCORRECT

- a** - Check Valve Retainer
- b** - Check Valve (Plastic)

The new plastic check valve started in production at the serial numbers listed below.

MERCURY/MARINER	USA	Belgium
200 - 250 HP, 3.0 Litre Carb/EFI/Optimax	S/N 0G925400	
135 - 200 HP, 2.0/2.5 Litre Carb/EFI/Optimax	S/N 0G912213	
75 - 125 HP, 65 Jet	S/N 0G923899	S/N 0P054758
40 - 60 HP	S/N 0G919929	S/N 0P054357
30 - 40 HP	S/N 0G919618	S/N 0P054357

PRIMER BULB:

The current style check valves used in the primer bulb may stick closed, causing a fuel restriction. This is more likely to occur at idle speed, in HOT weather conditions or when using winter blend fuels. A new primer bulb **P/N 13330A5** has been developed to help resolve this condition. The new bulb uses a round check ball and spring arrangement, rather than the current shuttle style check valve.

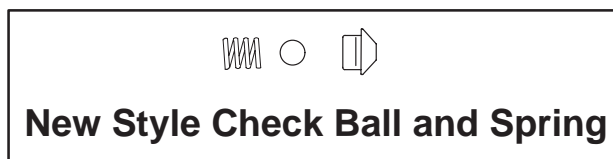
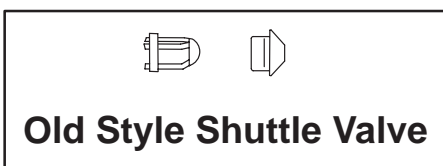

The new primer bulb started in production at the serial numbers listed below.

MERCURY/MARINER	USA	Belgium
All V-6 115-250 HP	S/N 0T144003	
75 - 125 HP, 80 Jet	S/N 0T089012	S/N 0P063645
75/90 4 Stroke	S/N 0T143069	
60 HP and Below U.S. only	S/N 0T081656	
30 - 60 HP Belgium only		S/N 0P063194
9.9 - 25 HP Belgium only		S/N 0P060463

Parts Required

Qty. 1	P/N 21-857005A1	Repair kit pumps with two solid diaphragms
Qty. 1	P/N 21-42909A4	Repair kit pumps with oil mixing holes in one diaphragm
Qty. 1	P/N 13330A5	Primer bulb

Warranty

The normal factory warranty applies. The above items are considered a product improvement and does NOT suggest a recall or rework campaign. Warranty will not cover up-grades to engines if a failure has not occurred.