



Service Bulletin

Bulletin No. 2006-09
OEM No. 2006-03

Circulate to: Sales Manager Accounting Service Manager Technician Parts Manager

40-60 Horsepower FourStroke Rocker Shaft Screw Torque

Models Affected

Mercury/Mariner

Model Number	Serial Number Range
1A40311FZ	1C007212 through 1C023461
1A40312FZ	1C007216 through 1C023468
1A40412FZ	1C007595 through 1C021419
1A40411FZ	1C006636 through 1C021236
7A40412UZ	1C009074 through 1C021433
1F40213FZ	1C021078 through 1C021083
1A51411FZ	1C008136 through 1C021839
1A51412FZ	1C005750 through 1C021919
1A51452FZ	1C008136 through 1C020082
1A60411FZ	1C008573 through 1C022358
1A60452FZ	1C006576 through 1C021070
7A51412UZ	1C006591 through 1C010300
7A51452UZ	1C006597 through 1C008859
7A60412UZ	1C006602 through 1C012977
7A60452UZ	1C006612 through 1C006622
7A41452UZ	1C008840 through 1C021074
1A41452FZ	1C009203 through 1C021704
1A60412FZ	1C006432 through 1C022615
1E40312FB	0P438913 through 0P456779
1E40412FB	0P425776 through 0P458060
7E40412UB	0P425776 through 0P458060
7E60412UB	0P419746 through 0P458076
1E60452FB	0P420323 through 0P457593
7E60452UB	0P420323 through 0P457593
1E51412FB	0P419746 through 0P458076
7E51412UB	0P419746 through 0P458076
7E51452UB	0P419746 through 0P458076

THE INFORMATION IN THIS DOCUMENT IS CONFIDENTIAL AND PROTECTED BY COPYRIGHT AND IS THE PROPERTY OF MERCURY MARINE.

This document is provided for the sole and exclusive use of the original recipient as prescribed by Mercury Marine and may not be distributed or copied, digitally or otherwise, without the prior written consent of Mercury Marine.

Situation

Mercury Marine has identified engines listed above that may have incorrectly torqued rocker shaft screws. Incorrectly torqued rocker shaft screws can lead to increased valve lash, poor engine performance, and excessive noise.

Correction

NEW ENGINE (NOT YET RUN)

1. Remove the valve cover. Refer to **Section 4A** of the service manual for the valve cover removal procedure.
2. Remove the top rocker shaft screw. Lubricate the rocker shaft screw threads with 4-Stroke 10W-30 Outboard Oil. Reinstall the rocker shaft screw and tighten the rocker shaft screw to the specified torque.

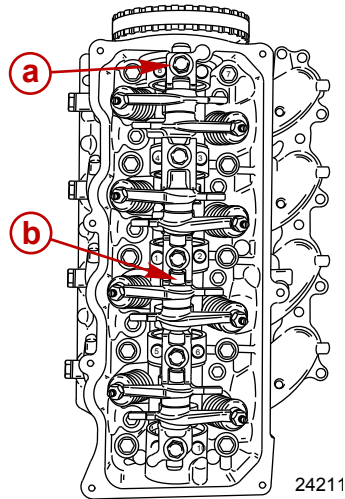

Four cylinder engine

a - Rocker shaft screw (M8 x 23)

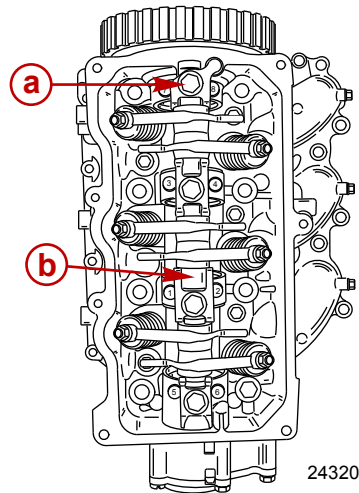

Three cylinder engine

b - Rocker arm shaft

Tube Ref No.	Description	Where Used	Part No.
 110	4-Stroke 10W-30 Outboard Oil	Top rocker shaft screw	92-802833A1

Description	Nm	lb. in.	lb. ft.
Top rocker shaft screw	9	80	

3. Remove the remaining rocker shaft screws one at a time, beginning with the bottom screw and working towards the top rocker shaft screw. Lubricate the rocker shaft screw threads with 4-Stroke 10W-30 Outboard Oil.

THE INFORMATION IN THIS DOCUMENT IS CONFIDENTIAL AND PROTECTED BY COPYRIGHT AND IS THE PROPERTY OF MERCURY MARINE.

This document is provided for the sole and exclusive use of the original recipient as prescribed by Mercury Marine and may not be distributed or copied, digitally or otherwise, without the prior written consent of Mercury Marine.

- Reinstall the rocker shaft screws. Tighten the rocker shaft screws in the sequence shown to the specified torque.

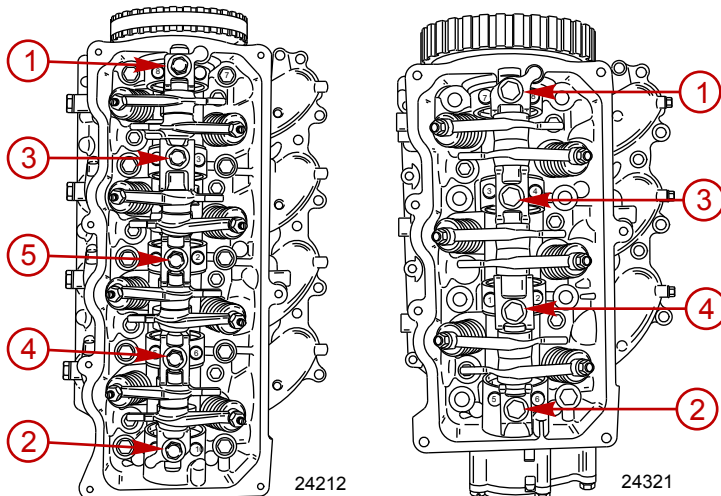

Four cylinder engine

Three cylinder engine

Description		Nm	lb. in.	lb. ft.
Rocker shaft screw	First	9	80	
	Final	18	160	

- Reinstall the valve cover. Refer to **Section 4A** of the service manual.
- Place a white paint mark on the valve cover above the oil fill to identify rework was completed.

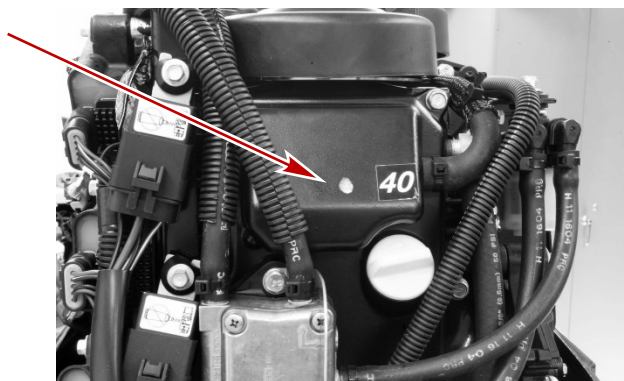

24234

- Test run the engine to verify no leaks are present and the engine functions properly.

ENGINE THAT HAS BEEN RUN

- Measure and record the cold valve lash for each valve. Refer to **Section 4A** of the service manual for proper valve lash measurement procedures.
- Compare the values recorded to the following:

THE INFORMATION IN THIS DOCUMENT IS CONFIDENTIAL AND PROTECTED BY COPYRIGHT AND IS THE PROPERTY OF MERCURY MARINE.

This document is provided for the sole and exclusive use of the original recipient as prescribed by Mercury Marine and may not be distributed or copied, digitally or otherwise, without the prior written consent of Mercury Marine.

- a. If the intake valve lash is 0.25-0.50 mm (0.010 - 0.020 in.) and the exhaust valve lash is 0.35 - 0.71 mm (0.014 - 0.028 in.), follow the previous procedure on torquing the rocker shaft screws. When the rocker shaft screws are retorqued to specifications, verify the valve lash is within the specifications as noted in **Section 4A** of the service manual. If the valve lash is not within the specification, readjustment is required.
- b. If the intake valve lash is greater than 0.50 mm (0.020 in.) or exhaust valve lash is greater than 0.71 mm (0.028 in.) a replacement rocker shaft is required. Follow the procedures for the rocker shaft replacement.

ROCKER SHAFT REPLACEMENT

1. Remove the rocker shaft screws securing the rocker shaft to the cylinder head

NOTE: The four cylinder engine has 5 rocker shaft screws. The three cylinder head has 4 rocker shaft screws.

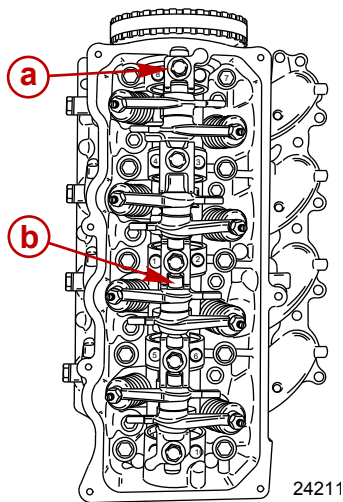

Four cylinder head

a - Rocker shaft screw M8 x 23

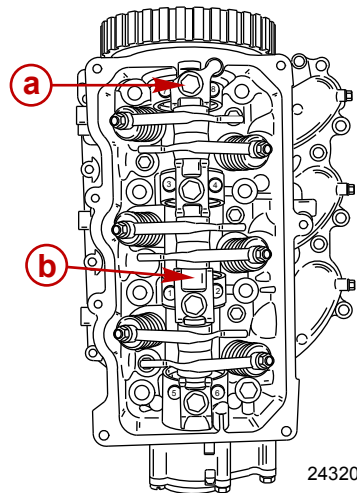

Three cylinder head

b - Rocker arm shaft

2. Remove the rocker shaft assembly from the cylinder head.
3. Remove the rocker arms, rocker arm springs, rocker arm brackets, and rocker arm overload springs from the rocker shaft. Retain the rocker arms, rocker arm springs, rocker arm brackets, and rocker arm overload springs for installation on the new rocker shaft.

THE INFORMATION IN THIS DOCUMENT IS CONFIDENTIAL AND PROTECTED BY COPYRIGHT AND IS THE PROPERTY OF MERCURY MARINE.

This document is provided for the sole and exclusive use of the original recipient as prescribed by Mercury Marine and may not be distributed or copied, digitally or otherwise, without the prior written consent of Mercury Marine.

4. Loosen all of the valve lash adjustment screws several turns out.

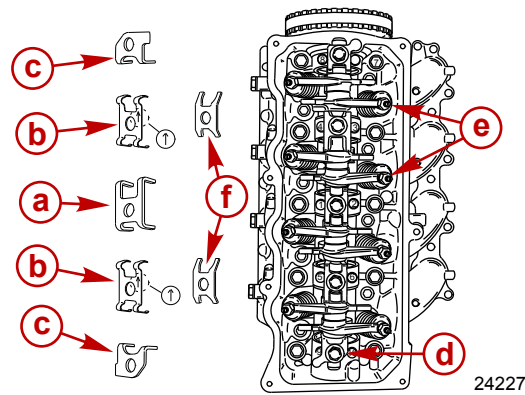

Four Cylinder Engine

- a** - Rocker arm bracket (1)
- b** - Rocker arm spring (2) arrow must point towards driven gear
- c** - Rocker arm bracket (2)
- d** - Rocker shaft screw (5) M8 x 23
- e** - Valve lash adjustment screw (loose)
- f** - Rocker arm overload spring (2)

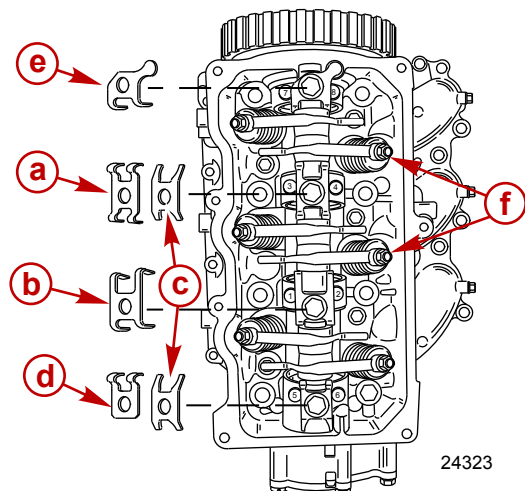

Three Cylinder Engine

- a** - Rocker arm spring (1) arrow must point toward driven gear
- b** - Rocker arm bracket (1)
- c** - Rocker arm overload spring (2) arrow must point toward driven gear
- d** - Rocker arm spring (1)
- e** - Rocker arm bracket (1)
- f** - Valve lash adjustment screw (loose)

5. Locate the end of the rocker shaft that must be oriented towards the top of the cylinder head. Ensure all of the oil holes will line up with the oil holes in the cylinder head.

THE INFORMATION IN THIS DOCUMENT IS CONFIDENTIAL AND PROTECTED BY COPYRIGHT AND IS THE PROPERTY OF MERCURY MARINE.

This document is provided for the sole and exclusive use of the original recipient as prescribed by Mercury Marine and may not be distributed or copied, digitally or otherwise, without the prior written consent of Mercury Marine.

IMPORTANT: The rocker shaft must be installed correctly with all of the oil holes properly aligned with the oil holes in the cylinder head. The three cylinder rocker shaft will have three oil holes that must be oriented towards the top of the cylinder head. The four cylinder rocker shaft will have four oil holes that must be oriented towards the top of the cylinder head.

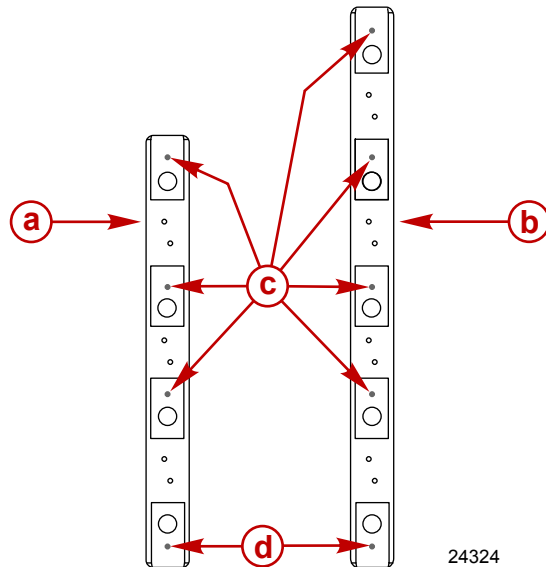

- a** - Three cylinder rocker shaft
- b** - Four cylinder rocker shaft
- c** - Oil holes oriented towards the top of the cylinder head
- d** - One oil hole oriented towards the bottom of the cylinder head

6. Lubricate the rocker arms and the new rocker shaft with 4-Stroke 10W-30 Outboard Oil.
7. Slide the rocker arms onto the rocker shaft as shown.

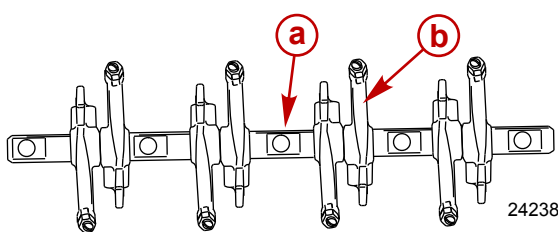

Four cylinder engine

a - Rocker shaft

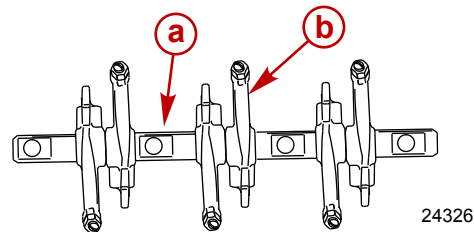

Three cylinder engine

b - Rocker arms

Tube Ref No.	Description	Where Used	Part No.
 110	4-Stroke 10W-30 Outboard Oil	Rocker shaft and rocker arms	92-802833A1

8. Lubricate the rocker shaft screw threads with 4-Stroke 10W-30 Outboard Oil.
9. Install the replacement rocker shaft to the cylinder head.
10. Install the rocker shaft assembly with the rocker arm brackets, rocker arm springs, and the rocker arm overload springs onto the cylinder head as shown.

THE INFORMATION IN THIS DOCUMENT IS CONFIDENTIAL AND PROTECTED BY COPYRIGHT AND IS THE PROPERTY OF MERCURY MARINE.

This document is provided for the sole and exclusive use of the original recipient as prescribed by Mercury Marine and may not be distributed or copied, digitally or otherwise, without the prior written consent of Mercury Marine.

NOTE: Ensure all of the valve lash adjustment screws are loose at this time.

11. Secure the rocker shaft assembly, rocker arm brackets, rocker arm springs, and the rocker arm overload springs to the cylinder head with the rocker shaft screws.

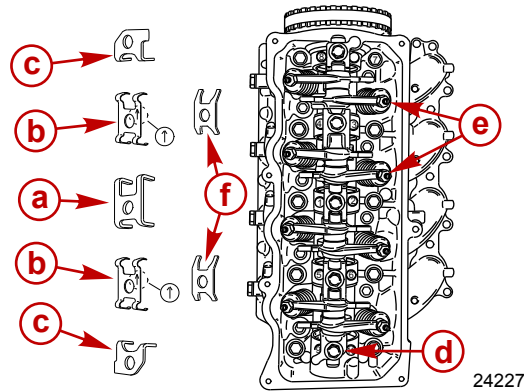

Four cylinder engine

- a** - Rocker arm bracket (1)
- b** - Rocker arm spring (2) arrow must point towards driven gear
- c** - Rocker arm bracket (2)
- d** - Rocker shaft screw (5) M8 x 23
- e** - Valve lash adjustment screw (loose)
- f** - Rocker arm overload spring (2)

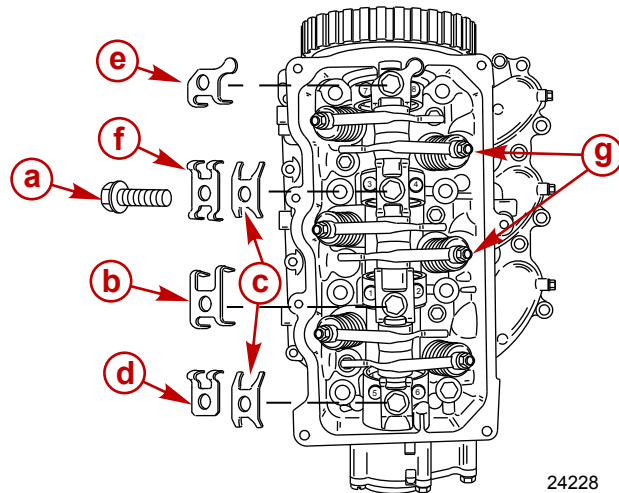

Three cylinder engine

- a** - Rocker shaft screw (4) M8 x 23
- b** - Rocker arm bracket (1)
- c** - Rocker arm overload spring (2) arrow must point toward driven gear
- d** - Rocker arm spring (1)
- e** - Rocker arm bracket (1)
- f** - Rocker arm spring (1) arrow must point toward driven gear
- g** - Valve lash adjustment screw (loose)

THE INFORMATION IN THIS DOCUMENT IS CONFIDENTIAL AND PROTECTED BY COPYRIGHT AND IS THE PROPERTY OF MERCURY MARINE.

This document is provided for the sole and exclusive use of the original recipient as prescribed by Mercury Marine and may not be distributed or copied, digitally or otherwise, without the prior written consent of Mercury Marine.

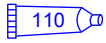
Tube Ref No.	Description	Where Used	Part No.
 110	4-Stroke 10W-30 Outboard Oil	Rocker shaft screw	92-802833A1

12. Following the sequence shown, tighten the rocker shaft screws in 2 steps to the specified torque.

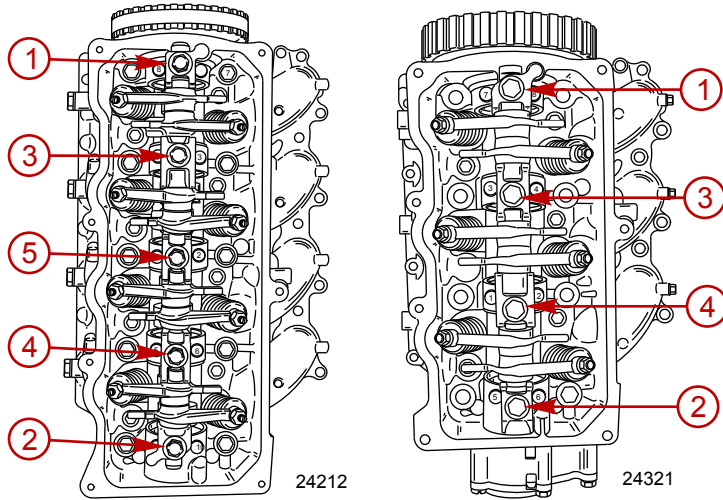

Four cylinder engine

Three cylinder engine

Description		Nm	lb. in.	lb. ft.
Rocker shaft screw	First	9	80	
	Final	18	160	

13. Adjust the valve lash. Refer to **Section 4A** of the service manual for the correct valve lash adjustment procedures.

14. Reassemble the valve cover. Refer to **Section 4A** of the service manual.

15. Place a white paint mark on the valve cover above the oil fill to identify rework was complete.

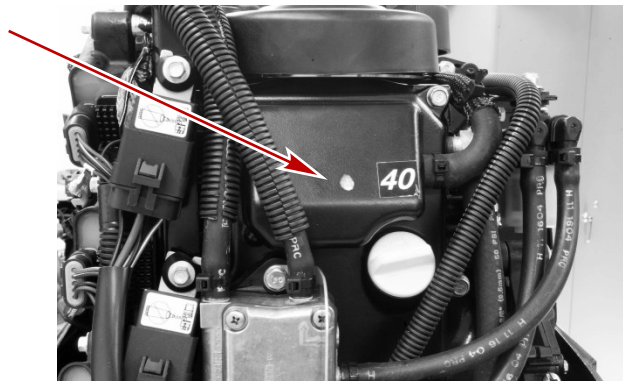

24234

16. Test run the engine to verify there are no leaks and that the engine functions properly.

Parts Required

- Mercury 4-Stroke 10W-30 Outboard Oil
- Rocker Shaft 834780T1 (3 cylinder) or Rocker Shaft 857085 1 (4 cylinder)

THE INFORMATION IN THIS DOCUMENT IS CONFIDENTIAL AND PROTECTED BY COPYRIGHT AND IS THE PROPERTY OF MERCURY MARINE.

This document is provided for the sole and exclusive use of the original recipient as prescribed by Mercury Marine and may not be distributed or copied, digitally or otherwise, without the prior written consent of Mercury Marine.

Owner Notification

All registered owners within the affected serial range will receive a letter from Mercury Marine. The letter will explain the situation and request that they contact their local dealer to set-up a time to have this bulletin performed.

Repair Identification

Engines reworked at the factory will contain an orange dot on the serial mat and/or a white dot on the cylinder head as shown below.



24244

Orange dot on the serial mat

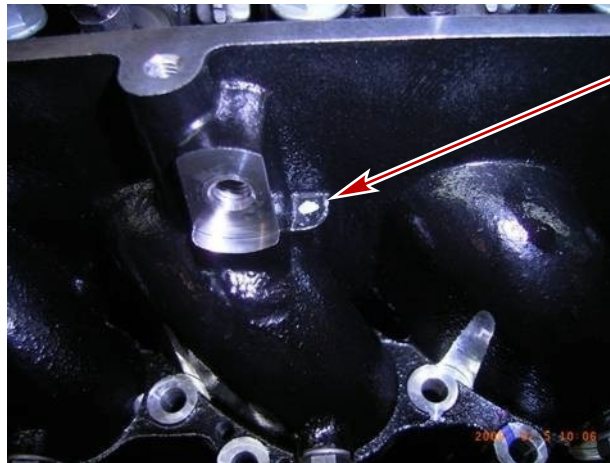

24243

White dot on the cylinder head

THE INFORMATION IN THIS DOCUMENT IS CONFIDENTIAL AND PROTECTED BY COPYRIGHT AND IS THE PROPERTY OF MERCURY MARINE.

This document is provided for the sole and exclusive use of the original recipient as prescribed by Mercury Marine and may not be distributed or copied, digitally or otherwise, without the prior written consent of Mercury Marine.

Engines repaired by dealers will have a white paint mark on the valve cover.

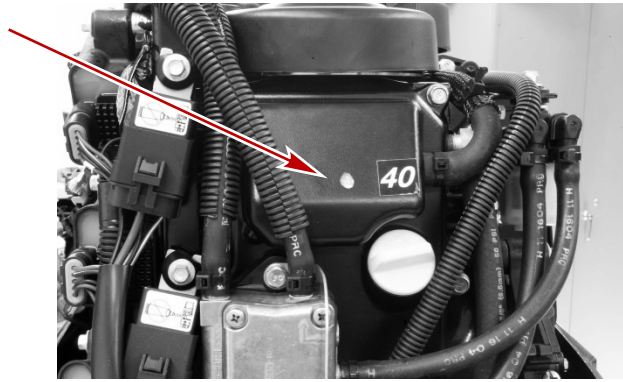

24234

Warranty

WARRANTY CLAIM PROCEDURE FOR NEW ENGINE (NOT YET RUN)

Mercury Marine will credit the dealer for the cost of parts and labor. Complete warranty claim listing:

- Outboard serial number
- 1.0 hour labor
- Warranty Flat Rate Code SB10
- Part Code 425
- Failure Code 00

WARRANTY CLAIM PROCEDURE FOR ENGINE THAT HAS BEEN RUN BUT DOES NOT NEED ROCKER SHAFT REPLACEMENT

Mercury Marine will credit the dealer for the cost of parts and labor. Complete warranty claim listing:

- Outboard serial number
- 1.2 hour labor
- Warranty Flat Rate Codes SB10 and SB02
- Part Code 425
- Failure Code 00

WARRANTY CLAIM PROCEDURE FOR ENGINE THAT HAS BEEN RUN AND NEEDS ROCKER SHAFT REPLACEMENT

Mercury Marine will credit the dealer for the cost of parts and labor. Complete warranty claim listing:

- Outboard serial number
- 1.5 hour labor
- Warranty Flat Rate Codes SB10 and SB05
- Part Code 425
- Failure Code 00
- Rocker Shaft Part number 834780T1 (3 cylinder) or 857085 1 (4 cylinder)

THE INFORMATION IN THIS DOCUMENT IS CONFIDENTIAL AND PROTECTED BY COPYRIGHT AND IS THE PROPERTY OF MERCURY MARINE.

This document is provided for the sole and exclusive use of the original recipient as prescribed by Mercury Marine and may not be distributed or copied, digitally or otherwise, without the prior written consent of Mercury Marine.

US & CANADA

Complete/process the claim via MercNET or return a warranty claim form.

INTERNATIONAL

Follow the instructions issued by the Marine Power International office or by an authorized Marine Power Distributor.

THE INFORMATION IN THIS DOCUMENT IS CONFIDENTIAL AND PROTECTED BY COPYRIGHT AND IS THE PROPERTY OF MERCURY MARINE.

This document is provided for the sole and exclusive use of the original recipient as prescribed by Mercury Marine and may not be distributed or copied, digitally or otherwise, without the prior written consent of Mercury Marine.

Dear Mercury Outboard Owner

Thank you for your purchase of a Mercury FourStroke Outboard engine. Mercury Marine is dedicated to providing superior reliability and customer satisfaction. As part of our commitment to superior customer satisfaction, we have determined that it is necessary to inspect the rocker shaft screws on your engine to insure the durability of your Mercury Outboard engine.

What is the condition?

It is possible that the rocker shaft screws on your engine may be incorrectly torqued, resulting in the loss of engine performance over time. To eliminate the possibility of this occurring, Mercury Marine will inspect the rocker shaft screws, valve lash, and rocker shaft at no charge to you.

What will Mercury Marine do?

Any authorized Mercury Marine dealer will perform the required inspection and if necessary replace your rocker shaft at no charge to you.

What should you do?

Please contact your Mercury Outboard dealer regarding Mercury Service Bulletin 2006-09 to schedule an appointment to have the rocker shaft screws inspected. Your dealer will be able to determine how long the repair will take on your engine.

Please present this notice to your dealer when you bring your boat in for your service appointment.

What if you have other questions or if you no longer own this engine?

Please contact your Mercury Outboard dealer or call Mercury Outboard Customer Service at 1-920-929-5040 between 7:30 AM and 5:30 PM CST.

We have sent this notice in the interest of your continued satisfaction with our product, and we sincerely regret any inconvenience this may cause you.

Thank you for boating with Mercury Marine

Mercury Marine Service