

Circulate to:     Sales Manager     Accounting     Service Manager     Technician     Parts Manager

## Official Recall Notification U.S. Federal Boat Safety Act - Power Steering/Automatic Power Switch (APS) Fuse Installation - Verado L4 and Verado L6

### Models Affected

Models Covered	Serial Number Or Year
All Multi-Engine Boat Packages Equipped with Mercury Power Steering and Powered by 135/150/175/200 Verado L4 or 200/225/250/275/300 Verado L6	1B538684 and below

### Situation

Mercury Marine has received reports of inconsistent power steering fuse placement on multi-engine boat packages powered by Verado four or six cylinder outboards. In case of a short in the power steering circuit, if the fuses are not properly located, there exists the potential for an ignition source. Mercury Marine's recommendation for the power steering wiring places a 90 amp fuse at the positive (+) terminal of each engines' starting battery, as well as a 90 amp fuse at the output terminal of the automatic power switch (APS). Please inspect the power steering wiring of any multi-engine Verado boat package. Wiring diagrams which depict typical power steering automatic power switch (APS) installations have been included with this bulletin. These diagrams should be used as a guide, as actual boat wiring may vary from boat manufacturer to manufacturer. If the boat being inspected has different wiring architecture, please consult the boat manufacturer. As an added measure of clarity, the wiring schematic decal applied to the APS housing has been revised to clearly illustrate the required fuses for both the APS and the engine starting batteries.

### Correction

**NOTE:** *Disconnect or turn off the boat batteries prior to performing this work.*

<b>⚠ WARNING</b>
<b>Performing service or maintenance without first disconnecting the battery can cause product damage, personal injury, or death due to fire, explosion, electrical shock, or unexpected engine starting. Always disconnect the battery cables from the battery before maintaining, servicing, installing, or removing engine or drive components.</b>

THE INFORMATION IN THIS DOCUMENT IS CONFIDENTIAL AND PROTECTED BY COPYRIGHT AND IS THE PROPERTY OF MERCURY MARINE.

This document is provided for the sole and exclusive use of the original recipient as prescribed by Mercury Marine and may not be distributed or copied, digitally or otherwise, without the prior written consent of Mercury Marine.

1. Replace existing automatic power switch (APS) schematic decal P/N 37-895370B with upgraded decal P/N 37-8M0030728.

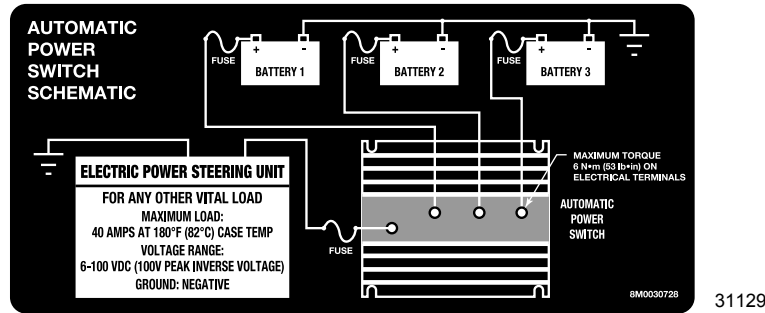

2. Inspect power steering/APS wiring fuse placement. Refer to attached wiring diagrams. **IMPORTANT:** Some multi-engine installations (such as quad engine installations) will require two or more automatic power switches (APS). These automatic power switches should be joined by a jumper cable (84-88807A33). This cable should be connected between the output terminal of each APS. This cable (8 gauge PVC @ 105 °C) should be no longer than 15.24 cm (6 in.). Refer to the appropriate multi-engine APS installation wiring diagram.

**IMPORTANT:** Do not overtighten the nuts onto the APS brass terminals. Overtightening the nuts onto the APS brass terminals will damage the terminals.

Description	Nm	lb. in.	lb. ft.
Nylon insert locknut (APS brass terminal)	6	53.1	
Nylon insert locknut (APS steel terminal)	10	88.5	

3. Install 90 amp fuse kits, as needed. Follow installation instructions provided with the fuse kit.

## Parts Required

Qty.	Description	Part Number
1	90 amp fuse kit	88-79023A93
1	Automatic power switch schematic decal	37-8M0030728

THE INFORMATION IN THIS DOCUMENT IS CONFIDENTIAL AND PROTECTED BY COPYRIGHT AND IS THE PROPERTY OF MERCURY MARINE.

This document is provided for the sole and exclusive use of the original recipient as prescribed by Mercury Marine and may not be distributed or copied, digitally or otherwise, without the prior written consent of Mercury Marine.

## Components Contained in Fuse Kit P/N 88-79023A93

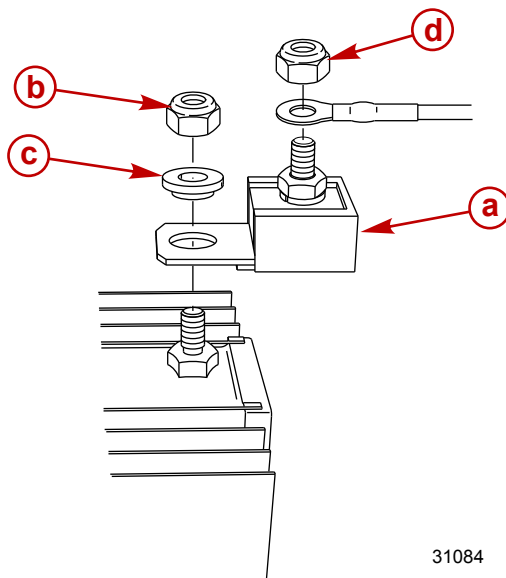

31084

Ref.	Qty.	Description	Part Number
a	1	90 amp fuse	88-79023A92
b	1	Nylon insert locknut 1/4-28	826708 9
c	1	APS terminal bushing	23-8M0011889
d	1	Nylon insert locknut 1/4-28, component of power steering pump	826708 9

Description	Nm	lb. in.	lb. ft.
Nylon insert locknut ("b" APS brass terminal)	6	53.1	
Nylon insert locknut ("b" APS steel terminal and "d")	10	88.5	

### Dealer/OEM Boat Inventory

Dealer/OEM inventory of affected multi-engine boat packages powered by Verado four or six cylinder outboards should be inspected and/or corrected prior to customer delivery.

### Dealer/OEM Parts Inventory

Master kits in dealer/OEM inventory should be upgraded prior to boat installation. Order one 90 amp fuse kit P/N 88-79023A93 and one APS decal P/N 37-8M0030728 for each previous part number master kit in your stock. Refer to the **Master Kit** table. Master kits listed as a new part number have been upgraded at Mercury Marine and contain the latest installation requirements.

Individually packaged automatic power switches (APS) P/N 87-895091K01 (listed as a previous part in the automatic power switch [APS] table), should be updated with APS decal P/N 37-8M0030728. Automatic power switches (APS) P/N 87-895091K02 have been updated at Mercury Marine.

THE INFORMATION IN THIS DOCUMENT IS CONFIDENTIAL AND PROTECTED BY COPYRIGHT AND IS THE PROPERTY OF MERCURY MARINE.

This document is provided for the sole and exclusive use of the original recipient as prescribed by Mercury Marine and may not be distributed or copied, digitally or otherwise, without the prior written consent of Mercury Marine.

**MASTER KITS**

Standard Helms		Tilt Helms	
Duals		Duals	
Previous P/N	New P/N	Previous P/N	New P/N
892380K06	892380K36	892560K06	892560K36
892380K13	892380K33	892560K13	892560K33
892380K14	892380K44	892560K14	892560K34
Triples		Triples	
892558K03	892558K33	892516K03	892516K33
892558K11	892558K31	892516K11	892516K31
892558K12	892558K32	892516K12	892516K32
Quads		Quads	
892558K21	892558K41	892516K21	892516K41
892558K22	892558K42	892516K22	892516K42
892558K23	892558K43	892516K23	892516K43

**AUTOMATIC POWER SWITCH (APS)**

Previous P/N	New P/N
87-895091K01	87-895091K02

**Owner Notification**

All registered owners within the affected serial number range will receive a letter from Mercury Marine. This letter will explain the situation and request that they contact their local dealer to set up a time to have this inspection performed.

**Warranty**

Mercury Marine will credit the dealer for the cost of parts and labor. Complete a warranty claim listing:

- Outboard serial numbers
- 0.2 hour labor - Inspection only
- Warranty Flat Rate Code: SB02 - Inspection/APS decal application

**or**

- 0.5 hour labor - Inspection/APS decal application/fuse installation
- Warranty Flat Rate Code: SB05 - Inspection/fuse installation
- Qty. as required, 90 amp fuse kit - P/N 88-79023A93
- Qty. 1, automatic power switch decal - P/N 37-8M0030728
- Part Code: 660
- Failure Code: 40

**US AND CANADA**

Complete and process the claim via MercNET or return a warranty claim form.

THE INFORMATION IN THIS DOCUMENT IS CONFIDENTIAL AND PROTECTED BY COPYRIGHT AND IS THE PROPERTY OF MERCURY MARINE.

This document is provided for the sole and exclusive use of the original recipient as prescribed by Mercury Marine and may not be distributed or copied, digitally or otherwise, without the prior written consent of Mercury Marine.

**INTERNATIONAL**

Follow instructions issued by the Marine Power International office or by an authorized Marine Power Distributor.

**Electrical Connections to the Power Steering Pump - Single Engine**

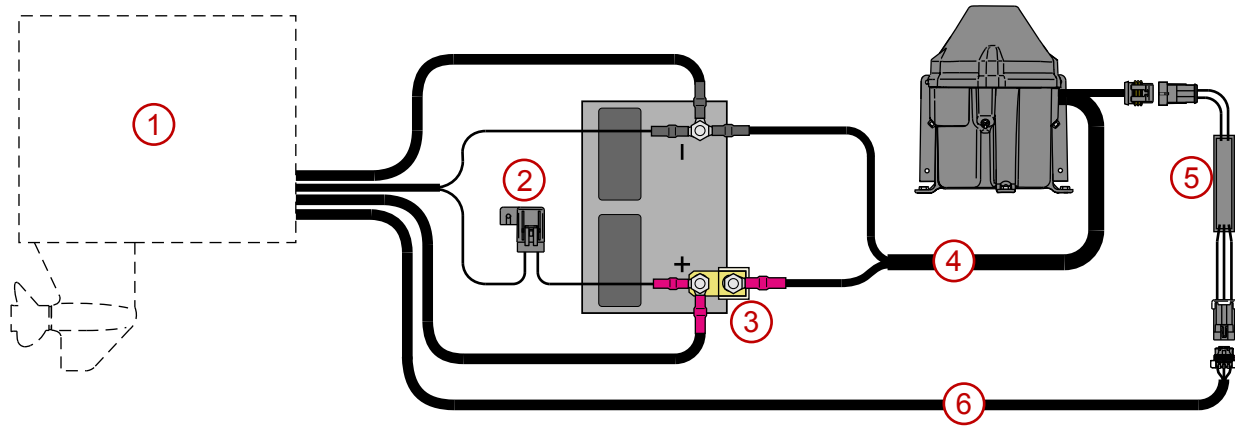

26469

- 1 - Engine
- 2 - DTS power harness fuse
- 3 - Fuse - 90 amp
- 4 - Power steering pump wire harness
- 5 - Power steering pump driver module harness
- 6 - Engine power steering signal harness

THE INFORMATION IN THIS DOCUMENT IS CONFIDENTIAL AND PROTECTED BY COPYRIGHT AND IS THE PROPERTY OF MERCURY MARINE.

This document is provided for the sole and exclusive use of the original recipient as prescribed by Mercury Marine and may not be distributed or copied, digitally or otherwise, without the prior written consent of Mercury Marine.

## Dual Engine APS Installation Wire Diagram

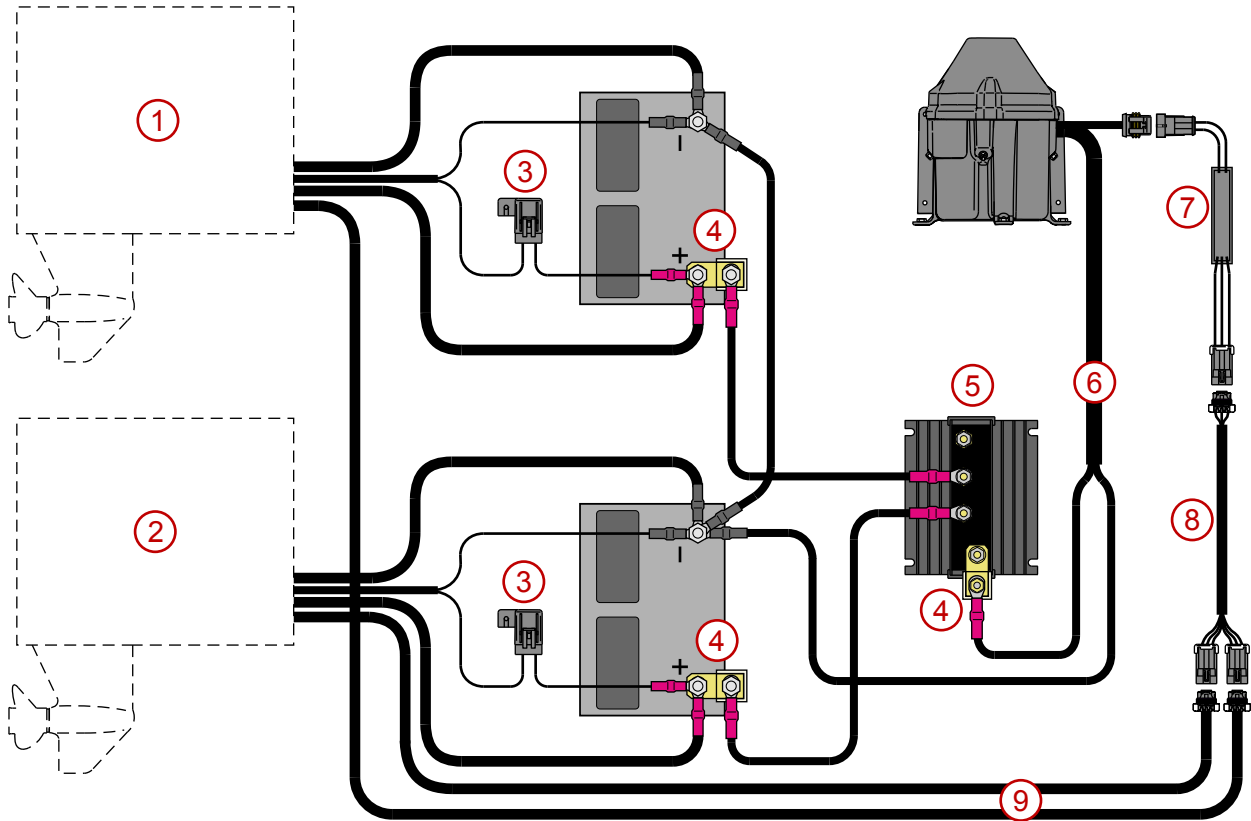

26507

- 1 - Port engine
- 2 - Starboard engine
- 3 - DTS power harness (fuse)
- 4 - Fuse - 90 amp (position as shown)
- 5 - Automatic power switch
- 6 - Power steering motor wire harness with the 90 amp fuse attached
- 7 - Power steering pump driver module harness
- 8 - Dual engine power steering adapter harness
- 9 - Engine power steering signal harness

THE INFORMATION IN THIS DOCUMENT IS CONFIDENTIAL AND PROTECTED BY COPYRIGHT AND IS THE PROPERTY OF MERCURY MARINE.

This document is provided for the sole and exclusive use of the original recipient as prescribed by Mercury Marine and may not be distributed or copied, digitally or otherwise, without the prior written consent of Mercury Marine.

## Triple Engine APS Installation Wire Diagram

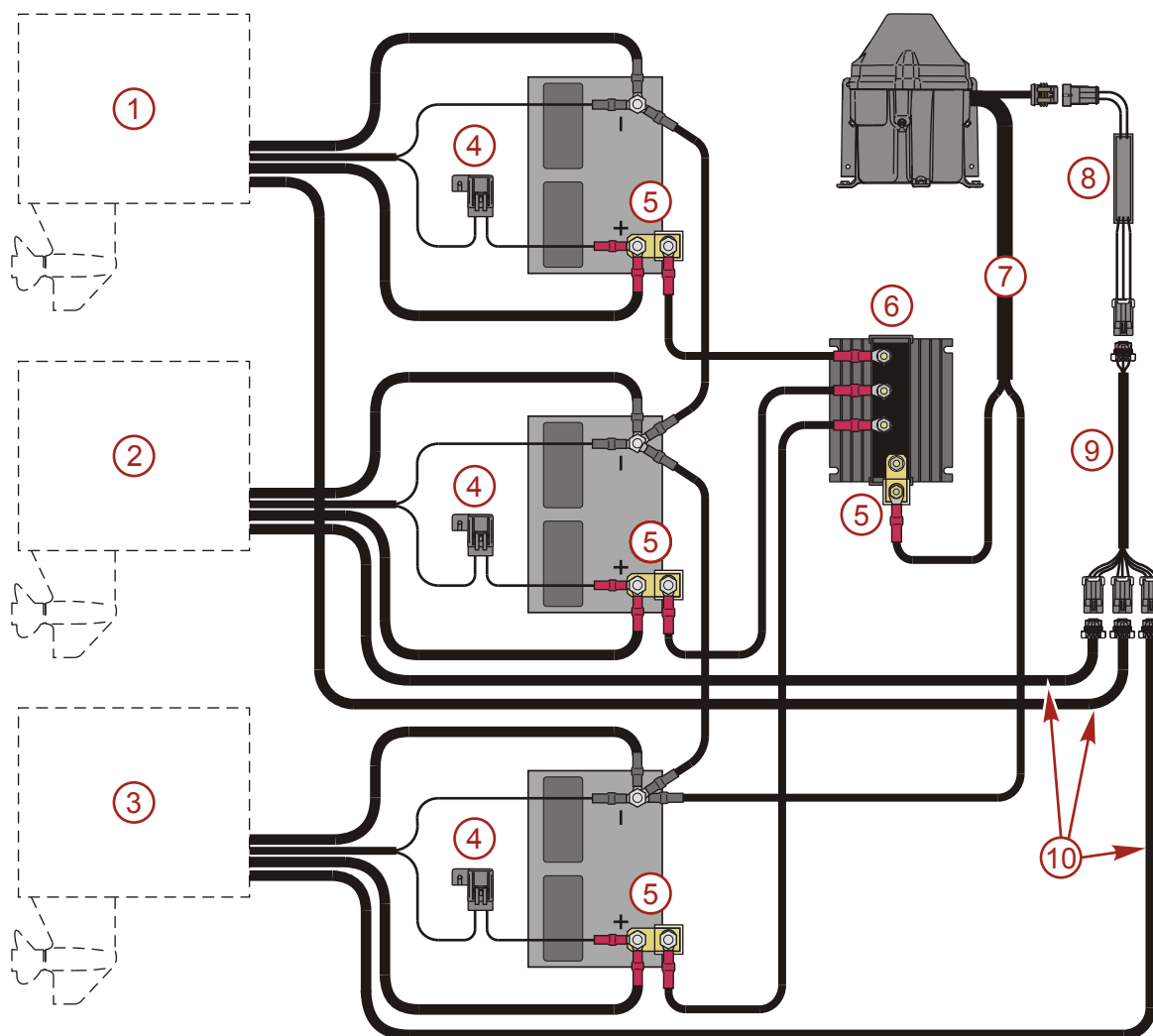

26519

- 1 - Port engine
- 2 - Center engine
- 3 - Starboard engine
- 4 - DTS power harness (fuse)
- 5 - Fuse - 90 amp (position as shown)
- 6 - Automatic power switch
- 7 - Power steering motor wire harness with the 90 amp fuse attached
- 8 - Power steering pump driver module harness
- 9 - Triple engine power steering adapter harness
- 10 - Engine power steering signal harness

THE INFORMATION IN THIS DOCUMENT IS CONFIDENTIAL AND PROTECTED BY COPYRIGHT AND IS THE PROPERTY OF MERCURY MARINE.

This document is provided for the sole and exclusive use of the original recipient as prescribed by Mercury Marine and may not be distributed or copied, digitally or otherwise, without the prior written consent of Mercury Marine.

### Quad Engine APS Installation Wire Diagram

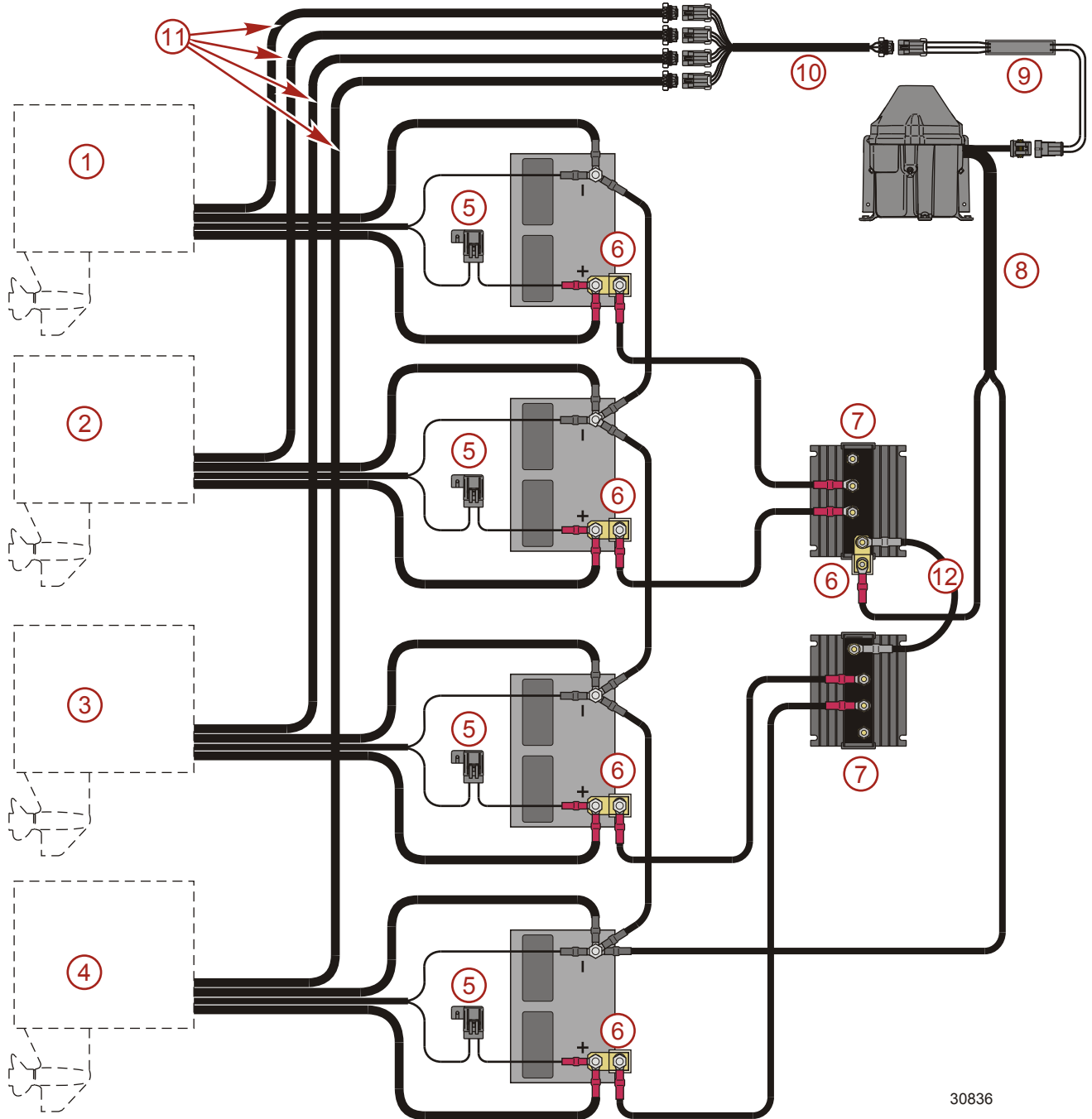

30836

THE INFORMATION IN THIS DOCUMENT IS CONFIDENTIAL AND PROTECTED BY COPYRIGHT AND IS THE PROPERTY OF MERCURY MARINE.

This document is provided for the sole and exclusive use of the original recipient as prescribed by Mercury Marine and may not be distributed or copied, digitally or otherwise, without the prior written consent of Mercury Marine.



- 1 - Port engine
- 2 - Port inner engine
- 3 - Starboard inner engine
- 4 - Starboard engine
- 5 - DTS power harness (fuse)
- 6 - Fuse - 90 amp (position as shown)
- 7 - Automatic power switch (APS)
- 8 - Power steering pump wire harness with 90 amp fuse attached
- 9 - Power steering pump driver module harness
- 10 - Quad engine power steering adapter harness
- 11 - Engine power steering signal harness
- 12 - APS jumper wire 15.24 cm (6 in.) or less, 8 gauge PVC at 105 °C (84-88807A33)

THE INFORMATION IN THIS DOCUMENT IS CONFIDENTIAL AND PROTECTED BY COPYRIGHT AND IS THE PROPERTY OF MERCURY MARINE.

This document is provided for the sole and exclusive use of the original recipient as prescribed by Mercury Marine and may not be distributed or copied, digitally or otherwise, without the prior written consent of Mercury Marine.

## Official Notification of Federal Boat Safety Act Recall

Dear Mercury Verado Outboard Owner

Thank you for your purchase of a Mercury Verado Outboard engine. Mercury Marine is dedicated to providing superior product reliability and customer satisfaction. As part of our commitment to superior customer satisfaction, we have determined that it is necessary to have your boat's power steering/automatic power switch (APS) fuse wiring inspected to ensure the reliability of your Mercury Verado Outboard. This inspection is only necessary if your boat package is powered by more than one Verado outboard (duals, triples, quads) and equipped with power steering. If your boat is not equipped with power steering, or your boat is powered by a single Verado outboard, no inspection is required and this letter may be disregarded.

### **IMPORTANT:**

#### **Verado powered boats requiring service under this recall:**

- **Dual, Triple, or Quad 200/225/250/275/300 (6 cylinder) Verado powered boats**
- **Dual outboard 135/150/175/200 (4 cylinder) Verado powered boats equipped with power steering**

#### **Verado powered boats not requiring service under this recall:**

- **Single 200/225/250/275/300 (6 cylinder) Verado powered boats**
- **Single 135/150/175/200 (4 cylinder) Verado powered boats**
- **Dual outboard 135/150/175/200 (4 cylinder) Verado powered boats equipped with either hydraulic or mechanical steering (non power steering)**

### **What is the condition?**

Mercury Marine has identified a potential inconsistent fuse placement within the power steering/automatic power switch (APS) wiring on your multi Verado powered boat equipped with power steering. Improper fuse placement within the power steering/automatic power switch (APS) wiring could allow for inadequate wiring protection in the event of a short circuit or overload, which could provide an ignition source for any flammable materials in close proximity to the boat's wiring. Mercury Marine has taken every opportunity to prevent any possibility of this happening in the future.

### **What will Mercury Marine do?**

Any Verado Qualified Mercury Marine dealer will perform this power steering/automatic power switch (APS) Fuse Installation inspection.

### **What should you do?**

Please contact your Verado Qualified Mercury Outboard dealer and mention Service Bulletin 2007-19 to schedule an appointment to have your boat's power steering/automatic power switch fuse wiring inspected. Your dealer will be able to determine how long this inspection/correction will take on your boat. To locate your nearest Verado Qualified Mercury Outboard dealer, please use the Dealer Locator in the Mercury Marine Website:

<http://northamerica.mercurymarine.com/veradoqualifiedservice/> If you do not have access to the Internet, please call Mercury Outboard Customer Service at 920-929-5040 to locate your nearest Verado Qualified Mercury Outboard dealer.

**Please present this notice to your dealer when you bring your boat in for your service appointment.**

**What if you have other questions or if you no longer own this engine?**

Please contact your Mercury Outboard dealer or call Mercury Outboard Customer Service at 1-920-929-5040 between 7:30 AM and 5:30 PM CST.

We have sent this notice in the interest of your continued satisfaction with our product, and we sincerely regret any inconvenience this may cause you.

Thank you for boating with Mercury Marine.

Mercury Marine Service