

Circulate to: Sales Manager Accounting Service Manager Technician Parts Manager

Important New Model Information—V-8 200–300 and V-6 175–225

Models Covered

Model	Serial Number
V-8 200–300 and V-6 175–225 FourStroke/Pro XS/SeaPro/Verado Models	2B529482 and above
V-8 250R, V-8 300R/300R HD Racing Models	1E080500 and above

NOTE: For additional information, view the V-8—4.6L and V-6—3.4L FourStroke Outboards Accessories and Rigging Guide on MercNET>Handy Tools>Resources>Sales>US Mercury Product Guides.

Scope

Worldwide

Situation

The purpose of this bulletin is to highlight some key product information for the new V-8 200–300 and V-6 175–225 outboard models, to include FourStroke, Pro XS, SeaPro, Verado, and Racing.

- Steering system requirements—CMS models
- Steering system requirements—V-8 Verado and V-8 SeaPro AMS models
- Battery cables
- Battery isolator wiring requirements
- Clean power
- Fuel line primer bulb
- Gauge options
- Analog gauge connection for mechanical—non-DTS outboards
- Analog gauge connection for DTS outboards
- Speedometer—pitot connections
- Block water pressure tubing connection
- Hose connections at the rigging tube
- Analog block water pressure adapter kit
- Digital block water pressure sensor kits
- Digital oil level sensor kit—standard on Verado V-8
- Water-separating fuel filter with WIF sensor—outboard mounted
- Water-separating fuel filter kit with WIF sensor—vessel mounted
- Advanced sound control (ASC) harness/module kit—V-8 Verado only
- Repower harness kit—304.8 cm (10 ft)

THE INFORMATION IN THIS DOCUMENT IS CONFIDENTIAL AND PROTECTED BY COPYRIGHT AND IS THE PROPERTY OF MERCURY MARINE.

This document is provided for the sole and exclusive use of the original recipient as prescribed by Mercury Marine and may not be distributed or copied, digitally or otherwise, without the prior written consent of Mercury Marine.

- Rigging grommets—open option kits
- Big Tiller kits—CMS model 250 hp and below
- Propeller hub kit selection
- Driveshaft/housing conversion kits
- Gear housing removal and installation
- Special tools
- Diagnostic tool requirements
- Adaptive speed control propping with CDS G3

Steering System Requirements—CMS Models

CAUTION

Avoid a possible steering system failure due to incorrect steering cylinder installation. Mercury heavy-duty steering cylinders are designed to be gearcase/propeller rotation specific. Right-hand rotation outboards require a right-hand steering cylinder and left-hand (counterrotation) outboards require a counterrotation steering cylinder. Always confirm that the correct cylinder is paired with the correct outboard.

Mechanical Steering

IMPORTANT: Do not use mechanical steering with these engines.

Hydraulic Steering—Non Power Steering

Use Mercury heavy-duty steering cylinders fitted with compression fittings.

Hydraulic Power Steering

Use Mercury heavy-duty steering cylinders fitted with O-ring face seal fittings.

Multiple Engine Steering Installations—CMS Models

Dual Outboard Steering Options

Maximum Combined 500 HP

Single Cylinder/Dual Outboard: One right-hand HD steering cylinder mounted to the right-hand rotation outboard, using a tie bar kit to connect to the left-hand (counterrotation) outboard.

Maximum Combined 600 HP

Dual Cylinder/Dual Outboard: One right-hand HD steering cylinder mounted to the right-hand rotation outboard, and one left-hand HD steering cylinder mounted to the left-hand (counterrotation) outboard. Steering cylinders are connected using a dual outboard tie bar kit.

Triple Outboard Steering

Triple Cylinder/Triple Outboard: One right-hand HD steering cylinder mounted to the right-hand rotation outboard (starboard outboard location), one left-hand HD steering cylinder mounted to the left-hand (counterrotation) outboard (port outboard location), and one HD steering cylinder from the triple outboard tie bar kit mounted to the center outboard. Steering cylinders are connected using tie bars and hardware from the triple outboard tie bar kit.

Steering System Requirements—V-8 Verado and V-8 SeaPro AMS Models

Important Steering Installation Guidelines

IMPORTANT: Joystick piloting has its own special requirements and is not part of this steering installation.

IMPORTANT: Do not use more than two cylinders with non-joystick multiple engine installations. The power steering pump is designed to support the displacement of two steering cylinders. Address concerns to your Mercury product application engineer.

THE INFORMATION IN THIS DOCUMENT IS CONFIDENTIAL AND PROTECTED BY COPYRIGHT AND IS THE PROPERTY OF MERCURY MARINE.

This document is provided for the sole and exclusive use of the original recipient as prescribed by Mercury Marine and may not be distributed or copied, digitally or otherwise, without the prior written consent of Mercury Marine.

There are a few important installation guidelines that must be considered when installing the steering components on multiengine installations. Installing the wrong steering helm and cylinder configuration may result in a less than acceptable steering wheel lock-to-lock ratio.

- A 40 cc displacement helm should be used on single cylinder and liquid tie bar installations. This will yield four full turns, lock-to-lock.
- A 50 cc displacement helm should be used on all dual cylinder installations rigged in parallel. This will yield 6.4 turns, lock-to-lock.

Multiple Engine Steering Requirements

Tie Bar

To install the front-mounted steering tie bars, follow the instructions included with the steering tie bar kit and observe the following guidelines:

- Dual engine application—dual outboard tie bar kit
- Triple engine application—dual outboard tie bar kit with a Plus One tie bar kit—two steering cylinders, starboard and port engines
- Quad engine application—dual outboard tie bar kit with two Plus One tie bar kits—two steering cylinders, starboard and port engines

CAUTION

Coupling multiple engines of this model with a rear-mounted tie bar can cause cylinder distortion and premature engine failure. Use a front-mounted tie bar on multiple-engine applications of this model.

Multiple Steering Cylinders

On some large/heavy dual outboard boats, the steering forces generated in extreme maneuvers may create loads that exceed the pump's pressure capacity, where the operator may feel intermittent periods of load feedback at the steering wheel. The steering wheel may feel hard to turn for brief periods during these extreme maneuvers. If this happens and steering performance is deemed unacceptable for the application, a second accessory steering cylinder can be installed. When using a second steering cylinder, the 40 cc helm should be replaced with a 50 cc helm.

Steering Hose Connections to Steering Cylinder

IMPORTANT: The hydraulic steering hose connections at the steering cylinders differ between the bolt-on steering cylinders used on the CMS outboards and the integrated steering cylinders used on the AMS outboards. Please refer to the following diagrams and tables.

THE INFORMATION IN THIS DOCUMENT IS CONFIDENTIAL AND PROTECTED BY COPYRIGHT AND IS THE PROPERTY OF MERCURY MARINE.

This document is provided for the sole and exclusive use of the original recipient as prescribed by Mercury Marine and may not be distributed or copied, digitally or otherwise, without the prior written consent of Mercury Marine.

CMS Models—Hydraulic Steering

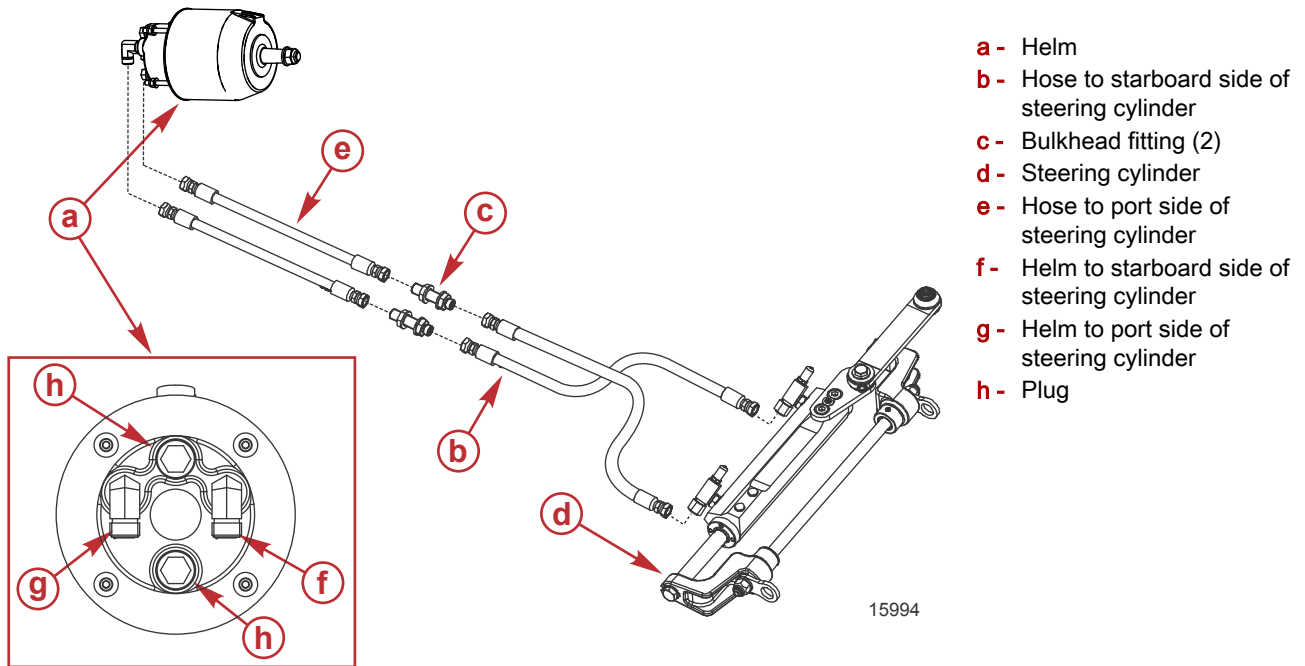

CMS Models—Power Steering

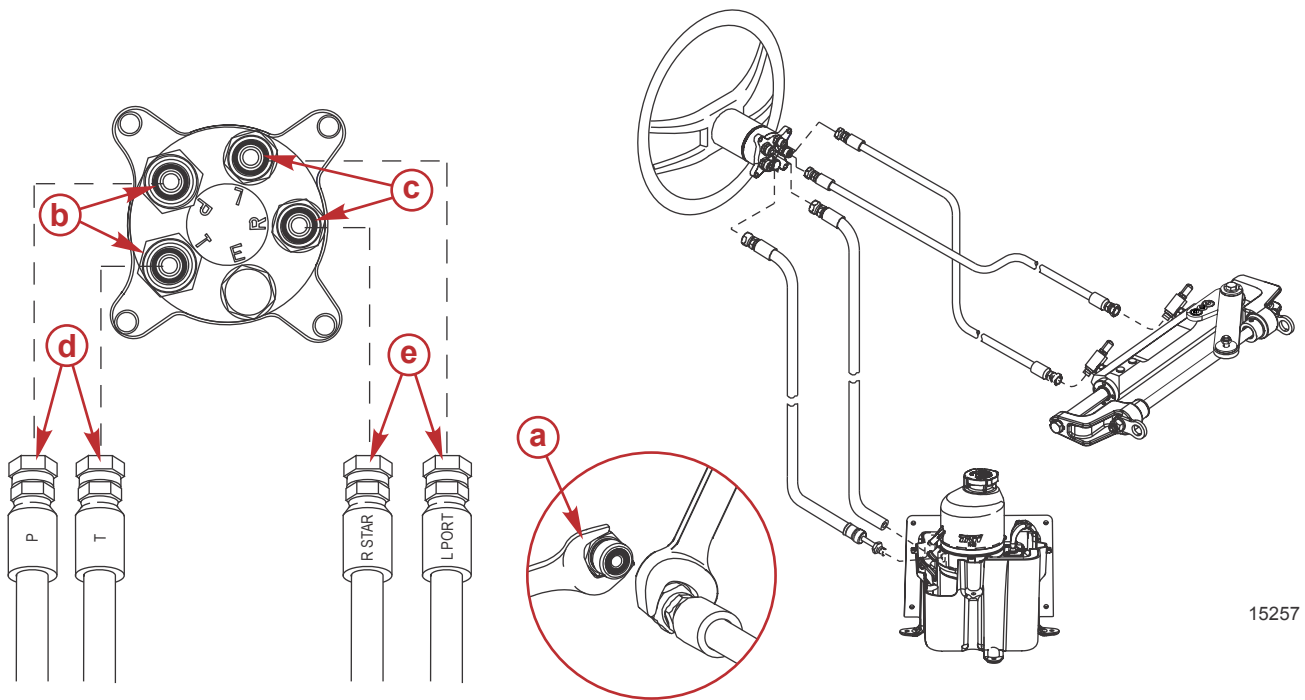

THE INFORMATION IN THIS DOCUMENT IS CONFIDENTIAL AND PROTECTED BY COPYRIGHT AND IS THE PROPERTY OF MERCURY MARINE.

This document is provided for the sole and exclusive use of the original recipient as prescribed by Mercury Marine and may not be distributed or copied, digitally or otherwise, without the prior written consent of Mercury Marine.

Helm Fitting ID Mark	Hose ID Mark	Description
P	P	Pressure from pump to helm
T	T	Tank low pressure return to pump
R	R STAR	Hose connects to port side of steering cylinder
L	L PORT	Hose connects to starboard side of steering cylinder

AMS Models—Power Steering

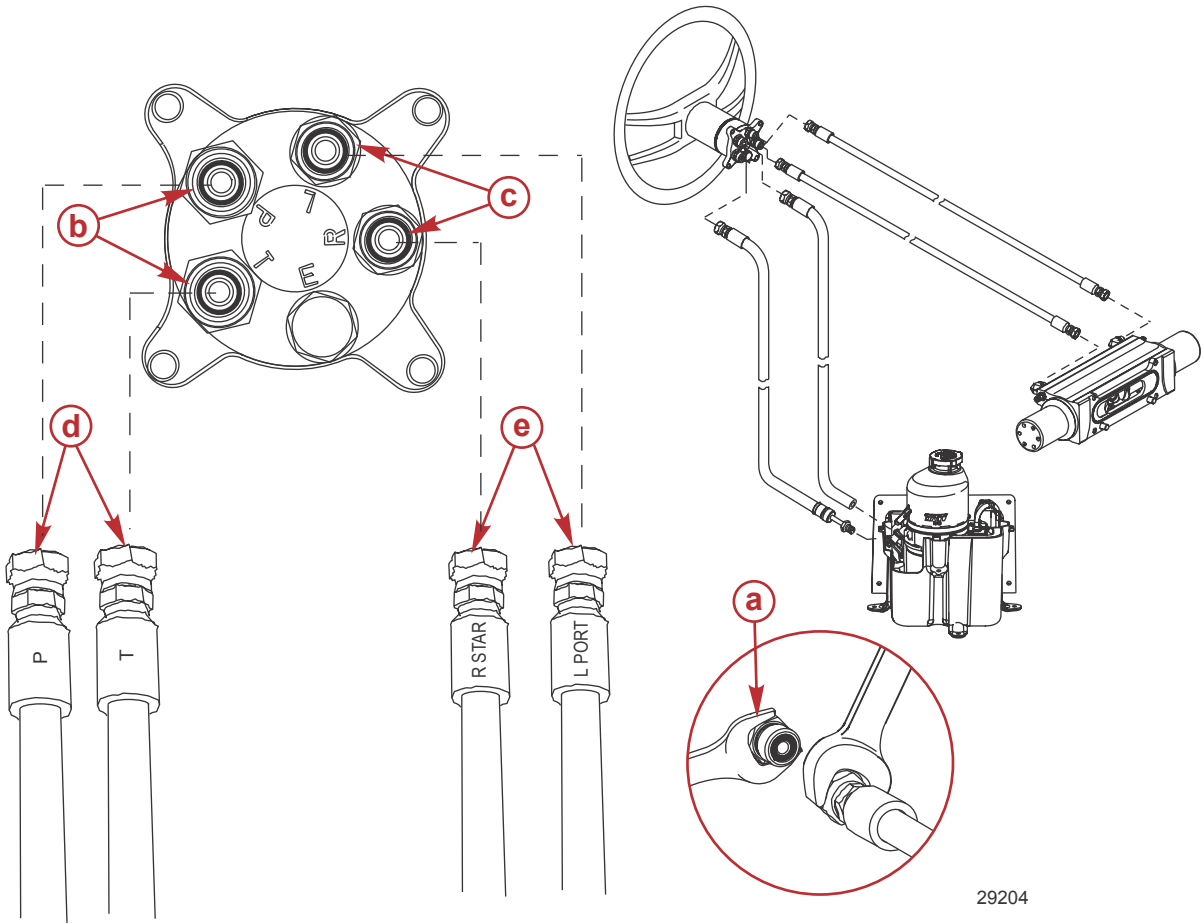

29204

- a** - Thin wrench
- b** - Helm hex fitting wrench size (P and T) - 19 mm (3/4 in.)
- c** - Helm hex fitting wrench size (R and L) - 16 mm (5/8 in.)
- d** - Hydraulic hose hex fitting wrench size (P and T) - 21 mm (13/16 in.)
- e** - Hydraulic hose hex fitting wrench size (R STAR and L PORT) - 18 mm (11/16 in.)

Helm Fitting ID Mark	Hose ID Mark	Description
P	P	Pressure from pump to helm
T	T	Tank low pressure return to pump
R	R STAR	Hose connects to starboard side of steering cylinder
L	L PORT	Hose connects to port side of steering cylinder

Battery Cables

Pro XS long shaft models are shipped with battery cables installed.

THE INFORMATION IN THIS DOCUMENT IS CONFIDENTIAL AND PROTECTED BY COPYRIGHT AND IS THE PROPERTY OF MERCURY MARINE.

This document is provided for the sole and exclusive use of the original recipient as prescribed by Mercury Marine and may not be distributed or copied, digitally or otherwise, without the prior written consent of Mercury Marine.

Models without installed cables have fish lines with clips secured to the power and ground studs, to allow the cables to be easily fed behind the intake runners. Remove the lines from the engine, prior to securing the cables to the appropriate studs. Refer to the outboard installation manual or service manual for proper battery cable sizing.

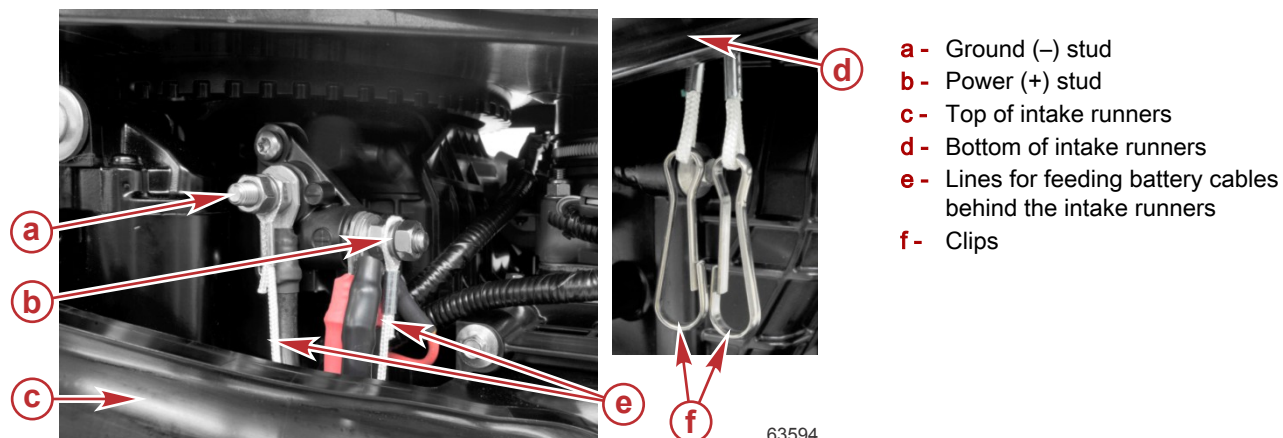

Battery Isolator Wiring Requirements

Model	Wire Gauge
CMS/8si alternator	Full load 88 amps, 4 AWG 105c wire
AMS/9si alternator	Full load 116 amps, 2 AWG 105c wire

Clean Power

A 2-pin clean power harness is shipped with CMS mechanical models only. All other models require the use of an accessory clean power kit.

Fuel Line Primer Bulb

IMPORTANT: There is no need to install a fuel line primer bulb into the fuel system of this outboard.

These new V-8 and V-6 FourStroke outboard models do not use a fuel primer bulb to prime the fuel system. However, the fuel system is not adversely affected with a primer bulb installed—as in the case of repowering an existing boat.

Gauge Options

NOTE: This outboard's PCM has a built-in AGI, and four analog gauge driver outputs—coolant temperature, oil pressure, trim position, and tachometer.

Function	Digital (SmartCraft)	Analog
Tachometer	Standard function on engine	AGI is built-into the engine's PCM and converts the digital signal into an analog gauge output* Mercury adjustable tachometer dial should be set to 4P
Speedometer	Standard sensor on engine	Standard sensor on engine with T-fitting and Legris hose (black) for analog hose connection to gauge
Block coolant pressure	DTS models: Standard sensor on engine	Mechanical models: Legris hose (gray) on engine for analog hose connection to mechanical gauge
	Mechanical models require optional kit: P/N 8M0142696 provides for digital sensor connection. Must be used in conjunction with SmartCraft gauge or MFD.	DTS models require optional kit: P/N 8M0145165 provides adapters and Legris hose (gray) for analog hose connection to mechanical gauge
Trim	Standard sensor on engine	Standard digital sensor on engine. AGI is built into the engine's PCM and converts the digital trim signal into an analog gauge output*.

THE INFORMATION IN THIS DOCUMENT IS CONFIDENTIAL AND PROTECTED BY COPYRIGHT AND IS THE PROPERTY OF MERCURY MARINE.

This document is provided for the sole and exclusive use of the original recipient as prescribed by Mercury Marine and may not be distributed or copied, digitally or otherwise, without the prior written consent of Mercury Marine.

Function	Digital (SmartCraft)	Analog
Block coolant temperature	Standard sensor on engine	Standard digital sensor on engine. AGI is built into the engine's PCM and converts the digital temperature signal into an analog gauge output*.
Engine oil pressure	Standard sensor on engine	Standard digital sensor on engine. AGI is built into the engine's PCM and converts the digital pressure signal into an analog gauge output*.
Engine oil temperature	Standard sensor on engine	Not available
Oil level	Verado model: Standard sensor on engine	Mechanical models: Optional digital oil level sensor kit P/N 8M0142265 provides audible warning. SmartCraft gauge or MFD required for visual warning.
	Non-Verado DTS models: Optional digital oil level sensor kit P/N 8M0142265	
Tank level	Capable of monitoring up to two (2) tanks. SmartCraft fuel/paddle harness kit P/N 8M0075945 and senders.	Tank level gauge options are available
Water-in-fuel (WIF) outboard mounted	Standard sensor on engine	Standard sensor on engine provides audible warning. SmartCraft gauge or MFD required for visual warning.
Water-in-fuel (WIF) vessel mounted	SeaPro models: Standard sensor on vessel mounted filter	SeaPro models: Standard sensor on vessel mounted filter
	Non-SeaPro models: Optional water-separating fuel filter kit with WIF sensor—vessel mounted kit P/N 8M0135386	Non-SeaPro models: Optional water-separating fuel filter kit with WIF sensor - vessel mounted kit P/N 8M0135386 provides audible warning. SmartCraft gauge or MFD required for visual warning.

* For mechanical (non-DTS) outboards, analog gauge outputs are wired through the 14-pin engine wiring harness and connected to the gauges using analog gauge harness accessory kits as listed.

Analog Gauge Connection for Mechanical (Non-DTS) Outboards

Option 1: Analog gauge harness (non DTS 14-pin)—connects to helm harness via 10-pin drop/connection.

Option 2: Analog gauge harness (non DTS 14-pin)—connects to junction box via 10-pin adapter harness (male to male connectors).

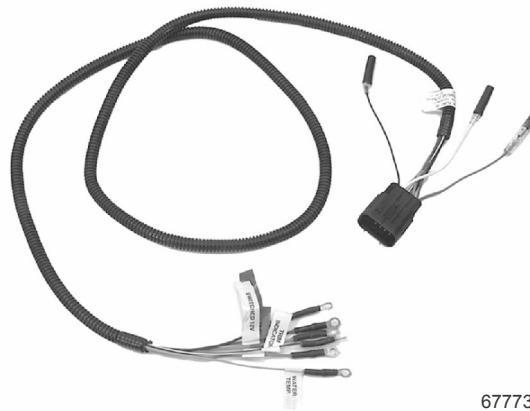

Description	Part Number
Analog gauge harness—1.524 m (5 ft)	892990T01
Analog gauge harness—3.048 m (10 ft)	892990T10

THE INFORMATION IN THIS DOCUMENT IS CONFIDENTIAL AND PROTECTED BY COPYRIGHT AND IS THE PROPERTY OF MERCURY MARINE.

This document is provided for the sole and exclusive use of the original recipient as prescribed by Mercury Marine and may not be distributed or copied, digitally or otherwise, without the prior written consent of Mercury Marine.

Description	Part Number
Analog gauge harness—4.572 m (15 ft)	892990T15



Description	Part Number
Adapter harness 10-pin—male to male connectors	892453A01

Analog Gauge Connection for DTS Outboards

NOTE: This outboard's PCM has built-in AGI and four analog gauge driver outputs—coolant temperature, oil pressure, trim position, and tachometer.

Option 1: The analog gauge harness (DTS)—connects to engine harness via 4-pin drop/connection at the top of the outboard's electrical box.

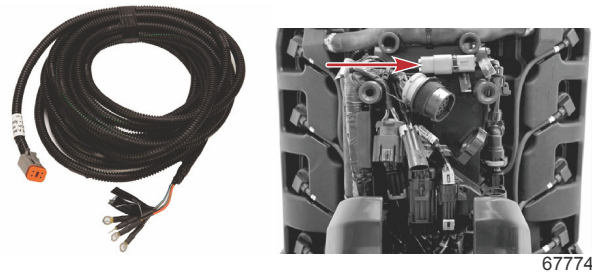

Description	Part Number
Analog gauge harness (DTS)—4.5 m (15 ft)	8M0095716
Analog gauge harness (DTS)—6.1 m (20 ft)	8M0095826
Analog gauge harness (DTS)—7.6 m (25 ft)	8M0095827
Analog gauge harness (DTS)—9.1 m (30 ft)	8M0095828

Option 2: The analog gauge harness (DTS)/extension harness connects to engine harness via 4-pin drop/connection at the top of the outboard's electrical box. This two-piece combination allows for the gauges to be prerigged, installed into the dash and connected to the engine using an extension harness.

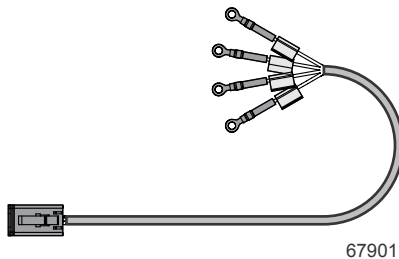

THE INFORMATION IN THIS DOCUMENT IS CONFIDENTIAL AND PROTECTED BY COPYRIGHT AND IS THE PROPERTY OF MERCURY MARINE.

This document is provided for the sole and exclusive use of the original recipient as prescribed by Mercury Marine and may not be distributed or copied, digitally or otherwise, without the prior written consent of Mercury Marine.

Description	Part Number
Analog gauge harness (DTS)—90 cm (3 ft) 4-pin to ring terminals. Used in conjunction with extension harness below.	8M0150539

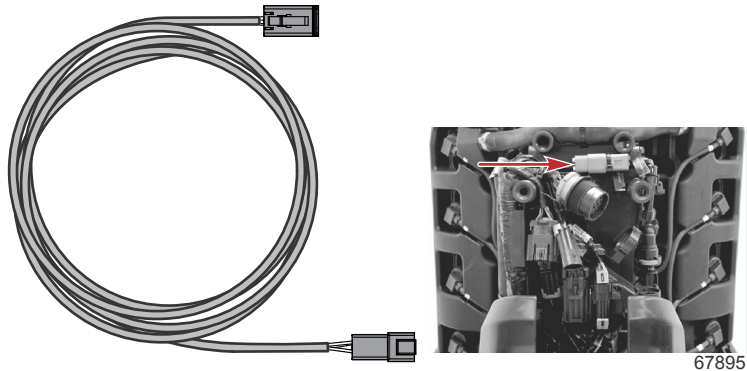

Description	Part Number
4-pin to 4-pin extension harness—5.2 m (17 ft)	8M0150477
4-pin to 4-pin extension harness—8.2 m (27 ft)	8M0150478

Speedometer (Pitot) Connections

NOTE: A black Legris hose is used for pitot connections.

All models are equipped for both analog and SmartCraft digital speedometer gauge connections. A SmartCraft digital pitot sensor is secured below the port intake runner and connected to the engine wiring harness. The Legris hose which runs from the pitot pickup in the gearcase to the digital sensor utilizes a T-fitting and extension hose for an analog connection. The extension hose is routed out through the rigging grommet/rigging tube and provides connection for the analog gauge kit.

IMPORTANT: Unused analog hose connections should be inspected to ensure that the red plug is installed and that the Legris hose is positioned neatly into the lower front cowl area.

Block Water Pressure Tubing Connection

For mechanical models: If the boat is equipped with a block water pressure gauge, the gray tubing can be used to operate the gauge. Feed the gray tubing through the accessories opening in the rigging grommet, as shown. Remove the plug from the coupler fitting, and make the connection to the tubing that runs to the block water pressure gauge.

If the tubing will not be used for a gauge:

1. Tuck the tubing inside the front of the engine cowling.
2. Keep the tubing clear of the throttle and shift cabling.
3. Ensure that the plug remains locked into the coupler fitting.

THE INFORMATION IN THIS DOCUMENT IS CONFIDENTIAL AND PROTECTED BY COPYRIGHT AND IS THE PROPERTY OF MERCURY MARINE.

This document is provided for the sole and exclusive use of the original recipient as prescribed by Mercury Marine and may not be distributed or copied, digitally or otherwise, without the prior written consent of Mercury Marine.

Hose Connections at the Rigging Tube

AMS Models

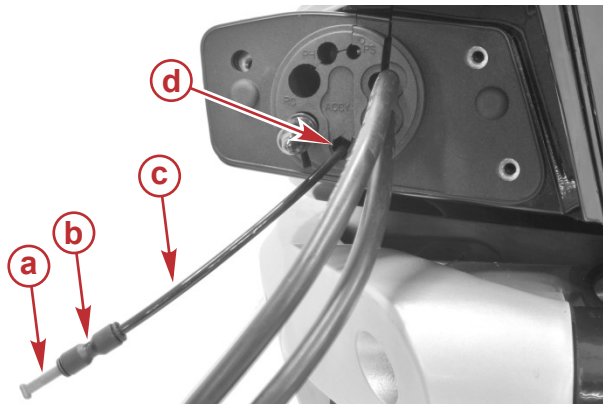

67165

- a - Plug
- b - Coupler fitting
- c - Water pickup tubing—black
- d - Accessories opening in rigging grommet

CMS Models

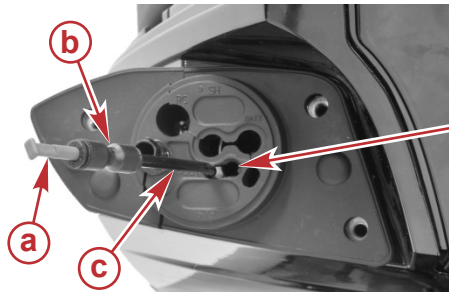

67163

DTS models

- a - Plug
- b - Coupler fitting
- c - Water pickup tubing—black
- d - Accessories opening in rigging grommet

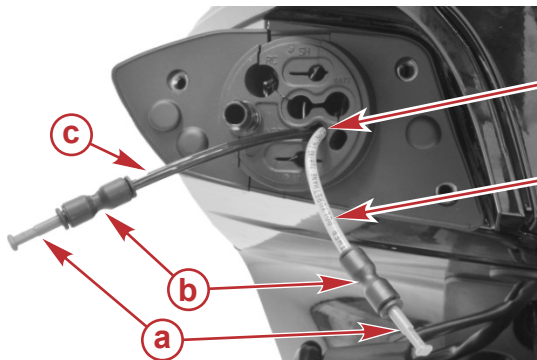

67164

Mechanical models

- a - Plug
- b - Coupler fitting
- c - Water pickup tubing—black
- d - Block water pressure tubing—gray
- e - Accessories opening in rigging grommet

Analog Block Water Pressure Adapter Kit

NOTE: A gray Legris hose is used for block water pressure connections.

NOTE: Mechanical models are shipped standard with an analog block water pressure feature.

THE INFORMATION IN THIS DOCUMENT IS CONFIDENTIAL AND PROTECTED BY COPYRIGHT AND IS THE PROPERTY OF MERCURY MARINE.

This document is provided for the sole and exclusive use of the original recipient as prescribed by Mercury Marine and may not be distributed or copied, digitally or otherwise, without the prior written consent of Mercury Marine.

Kit allows the use of an analog block water pressure gauge on DTS outboards and provides a connection for a Legris hose connection.

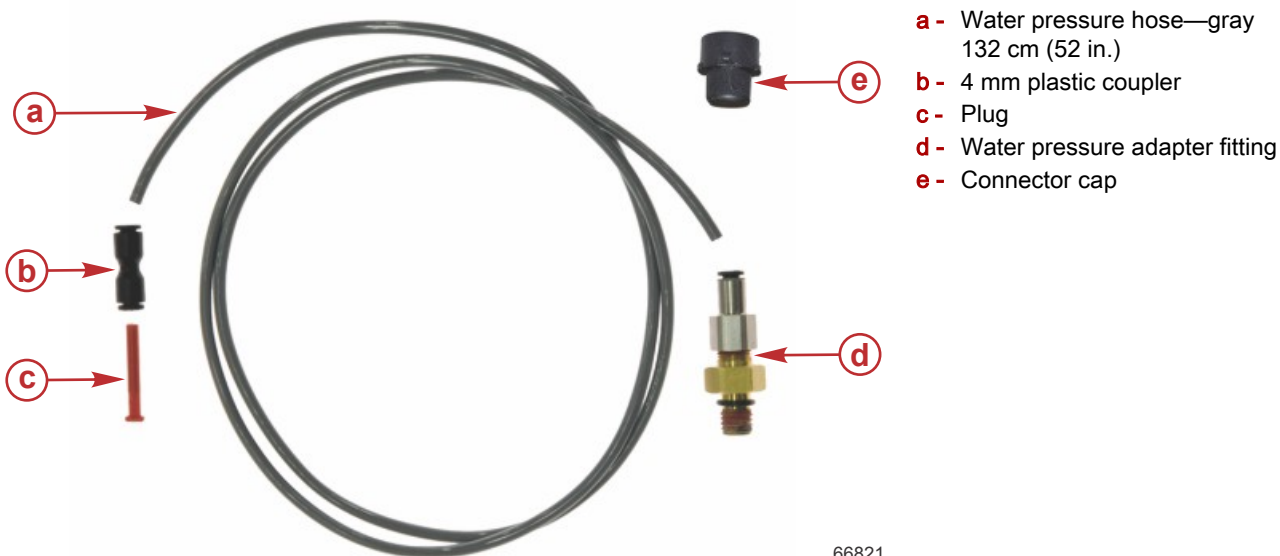

Description	Part Number
Analog block water pressure kit	8M0145165

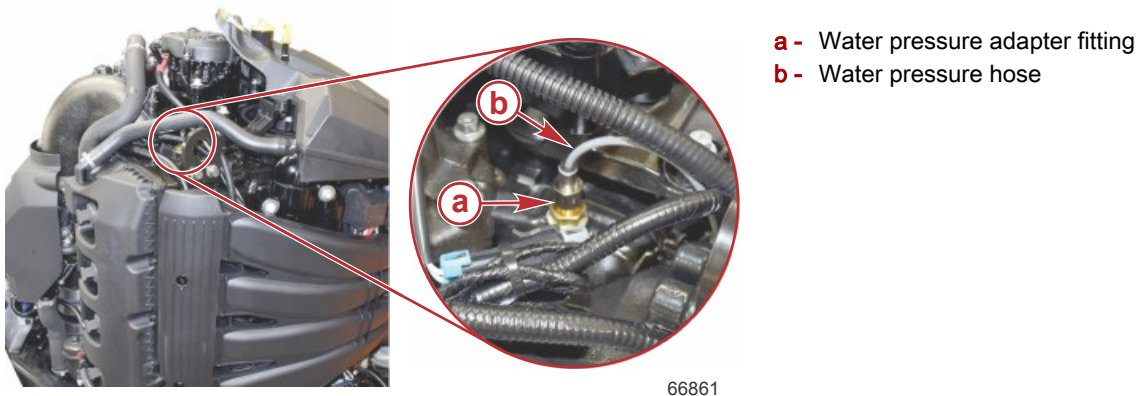

Digital Block Water Pressure Sensor Kit

NOTE: DTS models are shipped standard with a digital block water pressure feature.

Kit converts analog block water pressure equipped models to a digital system.



Description	Part Number
Digital block water pressure sensor kit	8M0142696

THE INFORMATION IN THIS DOCUMENT IS CONFIDENTIAL AND PROTECTED BY COPYRIGHT AND IS THE PROPERTY OF MERCURY MARINE.

This document is provided for the sole and exclusive use of the original recipient as prescribed by Mercury Marine and may not be distributed or copied, digitally or otherwise, without the prior written consent of Mercury Marine.

Digital Oil Level Sensor Kit—Standard on Verado V-8 Models

Digital oil level sensor checks engine oil at key-up and alerts the operator if the level is low. The system is compatible with:

- VesselView 403
- VesselView 502
- VesselView 703
- VesselView 903
- MercMonitor gauges
- SC 1000 gauges



- a** - Digital oil level sensor
- b** - Cable tie

Description	Part Number
Digital oil level sensor	8M0142265

Water-Separating Fuel Filter with WIF Sensor—Outboard Mounted

NOTE: Filter element is rated at 10 micron.

This filter is the service replacement for the standard outboard mounted inlet fuel filter.



Description	Part Number
Water-separating fuel filter with WIF sensor—outboard mounted	8M0106635

THE INFORMATION IN THIS DOCUMENT IS CONFIDENTIAL AND PROTECTED BY COPYRIGHT AND IS THE PROPERTY OF MERCURY MARINE.

This document is provided for the sole and exclusive use of the original recipient as prescribed by Mercury Marine and may not be distributed or copied, digitally or otherwise, without the prior written consent of Mercury Marine.

Water-Separating Fuel Filter Kit with WIF Sensor—Vessel Mounted

NOTE: Filter element is rated at 10 micron.

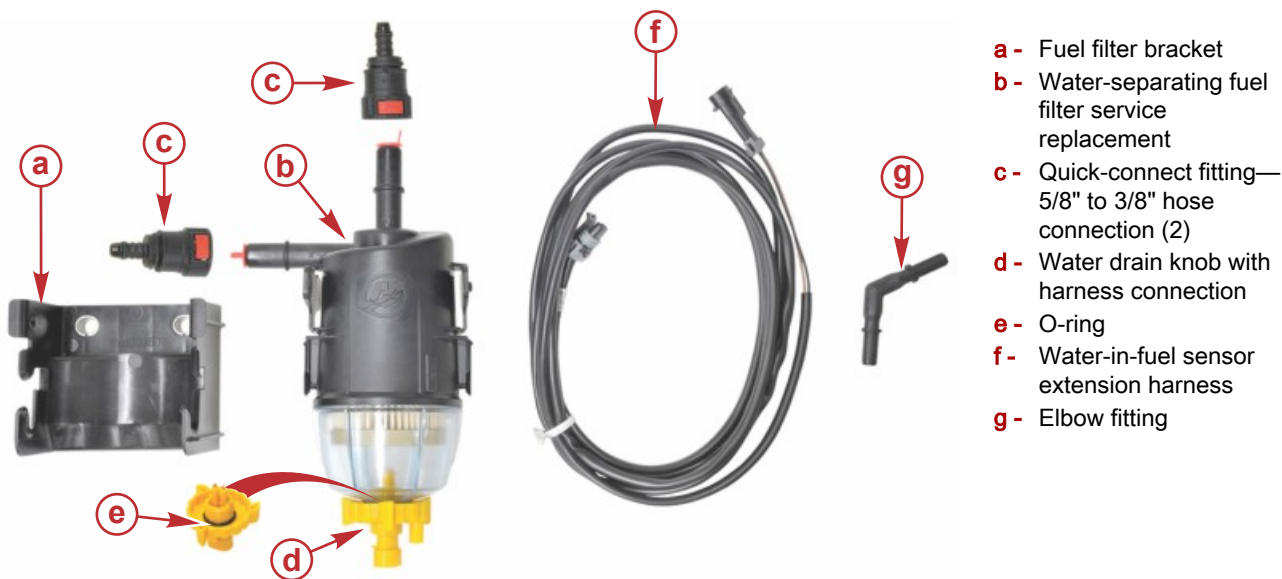

64206

Description	Part Number
Water-separating fuel filter kit with WIF sensor—vessel mounted	8M0135386

Water-Separating Fuel Filter Service Replacement—Vessel Mounted



64334

Description	Part Number
Water-separating fuel filter service replacement—vessel mounted	8M0126144

Advanced Sound Control (ASC) Harness/Module Kit—V-8 Verado Only

ASC uses an electronically controlled valve in the engine's idle relief system to bypass one of the mufflers and create a sportier sound when desired by the user.

There are two preferred ways to control it:

1. Via a SmartCraft display—VesselView 403/502/703/903, SC1000, or MercMonitor.

THE INFORMATION IN THIS DOCUMENT IS CONFIDENTIAL AND PROTECTED BY COPYRIGHT AND IS THE PROPERTY OF MERCURY MARINE.

This document is provided for the sole and exclusive use of the original recipient as prescribed by Mercury Marine and may not be distributed or copied, digitally or otherwise, without the prior written consent of Mercury Marine.

2. Via a control module wired to a helm-mounted rocker switch.

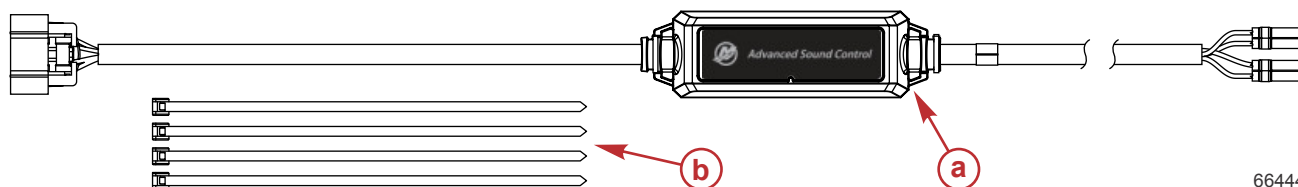

- a - Harness/module
- b - Cable ties (4)

Description	Part Number
Advanced sound control harness/module kit	8M0143359

Rocker Switch

This kit does not include a switch. Mercury Marine recommends using a three-position momentary rocker switch to connect to the advanced sound control (ASC) module. Switch should meet the following specifications:

- Contacts: momentary DPST (double pole single throw), (ON)-OFF-(ON)
- Rating: 0.4 VA at 24 VDC (Max) resistive or greater
- Illumination: yes (LED or incandescent) (color customer choice)
- Type: rocker or toggle or rotary
- Terminals: 0.25 in. quick-connect spade

Repower Harness Kit—304.8 cm (10 ft)

NOTE: Extension connections are not allowed in the rigging tube or inside the cowl.

The components in this kit are to be used to extend the existing wiring harnesses during a repower. This is done to be certain that no connections are to be made within the cowling of the motor. All harnesses to the engine wiring connections are to be made at the engine's electrical panel and covered with the electrical panel cover.

THE INFORMATION IN THIS DOCUMENT IS CONFIDENTIAL AND PROTECTED BY COPYRIGHT AND IS THE PROPERTY OF MERCURY MARINE.

This document is provided for the sole and exclusive use of the original recipient as prescribed by Mercury Marine and may not be distributed or copied, digitally or otherwise, without the prior written consent of Mercury Marine.

Description	Part Number
Repower harness kit	8M0145987

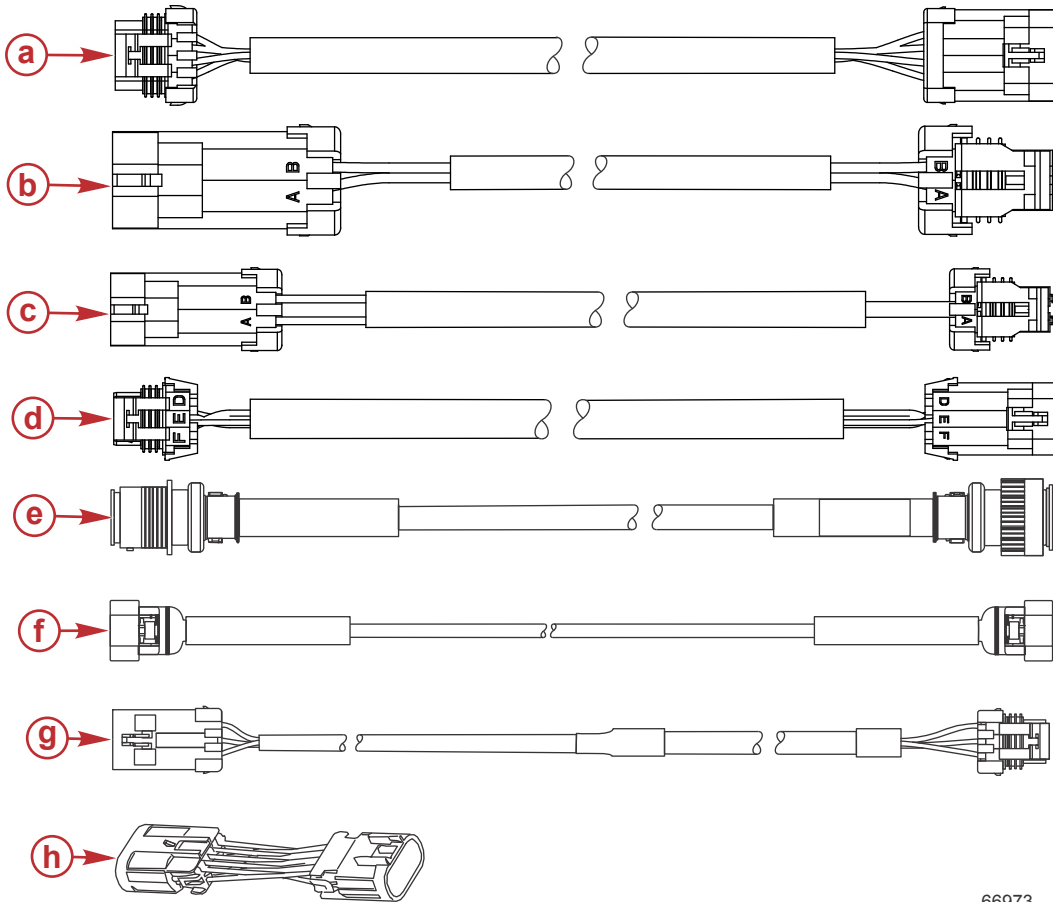

66973

- a** - 4-pin depth extension harness
- b** - 2-pin clean power extension harness
- c** - 2-pin water-in-fuel extension harness
- d** - 6-pin fuel/paddle wheel extension harness
- e** - 14-pin data cable extension harness
- f** - 10-pin SmartCraft extension harness
- g** - 3-pin power steering extension harness
- h** - 10-pin male-to-male gender adapter

THE INFORMATION IN THIS DOCUMENT IS CONFIDENTIAL AND PROTECTED BY COPYRIGHT AND IS THE PROPERTY OF MERCURY MARINE.

This document is provided for the sole and exclusive use of the original recipient as prescribed by Mercury Marine and may not be distributed or copied, digitally or otherwise, without the prior written consent of Mercury Marine.

Rigging Grommets—Open Option Kits

IMPORTANT: A rigging hose is required when using this open style rigging grommet. The use of the rigging adapter and rigging grommet is mandatory.

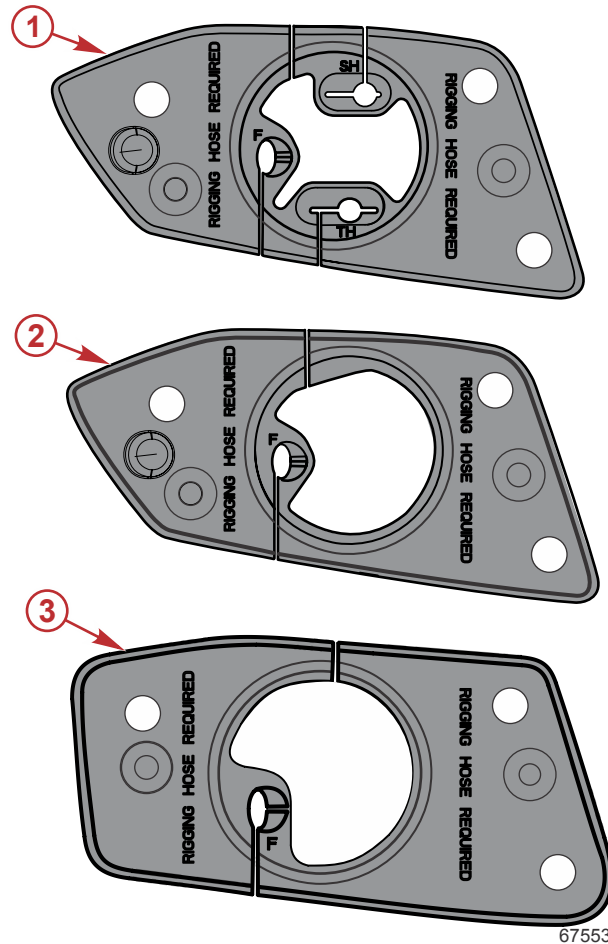

67553

Ref.	Description	Part Number
1	Open grommet for CMS mechanical models	8M0146953
2	Open grommet for CMS DTS models	8M0146954
3	Open grommet for AMS models	8M0146955

Big Tiller Kits—CMS Model 250 hp and Below

Description	Part Number
Big Tiller—CMS/mechanical with power steering	8M0133491
Big Tiler—CMS/DTS with power steering	8M0133492
Throttle and shift cable kit—CMS/mechanical with two cables at 88.9 cm (35 in.) long	8M0141907

Propeller Hub Kit Selection

Propeller Shaft	Good	Better	Best
1 inch	Flo-Torq II (175–300 HP) 835257K 6*	Flo-Torq IV (175–200 HP) 835257K10	SSR hub (175–300 HP) 8M0101602

THE INFORMATION IN THIS DOCUMENT IS CONFIDENTIAL AND PROTECTED BY COPYRIGHT AND IS THE PROPERTY OF MERCURY MARINE.

This document is provided for the sole and exclusive use of the original recipient as prescribed by Mercury Marine and may not be distributed or copied, digitally or otherwise, without the prior written consent of Mercury Marine.

Propeller Shaft	Good	Better	Best
1.25 inch	N/A	Flo-Torq Solid (175–200 HP) 840389K06	SSR hub (175–300 HP) 8M0101601

* Hub kit included with most propellers.

Driveshaft/Housing Conversion Kits

Order both a driveshaft housing conversion (spacer) kit and a matching driveshaft conversion kit per each installation. The maximum extension length available is extra, extra long (XXL), measuring 76.2 cm (30 in.). The XXL conversion option cannot be installed on a V-8 300 hp CMS outboard; however it can be installed on the V-8 300 hp SeaPro CMS model.

Driveshaft Housing Conversion (Spacer) Kits*

Description	Part Number
Driveshaft housing spacer kit - 12.7 cm (5 in.) Black	8M0142779
Driveshaft housing spacer kit - 12.7 cm (5 in.) Silver	8M0147047
Driveshaft housing spacer kit - 25.5 cm (10 in.) Black	8M0142787
Driveshaft housing spacer kit - 25.5 cm (10 in.) Silver	8M0147046



Driveshaft Conversion Kits*

Description	Part Number
4.8 in. gearcase long shaft - 50.8 cm (20 in.)	8M0146062
4.8 in. gearcase extra long shaft - 63.5 cm (25 in.)	8M0146063
4.8 in. gearcase extra, extra long shaft - 76.2 cm (30 in.)	8M0146064
5.4 in. gearcase long shaft - 50.8 cm (20 in.)	8M0146065
5.4 in. gearcase extra long shaft - 63.5 cm (25 in.)	8M0146066
5.4 in. gearcase extra, extra long shaft - 76.2 cm (30 in.)	8M0146067

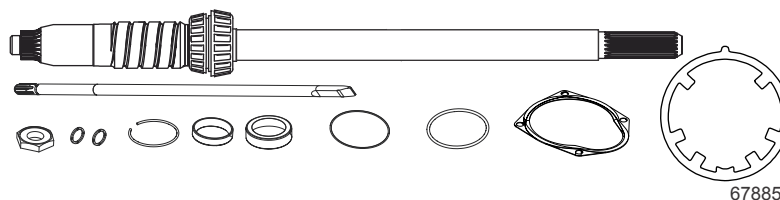

THE INFORMATION IN THIS DOCUMENT IS CONFIDENTIAL AND PROTECTED BY COPYRIGHT AND IS THE PROPERTY OF MERCURY MARINE.

This document is provided for the sole and exclusive use of the original recipient as prescribed by Mercury Marine and may not be distributed or copied, digitally or otherwise, without the prior written consent of Mercury Marine.

Gear Housing Removal and Installation

NOTE: It is not necessary to drain the oil sump when removing the gear housing.

IMPORTANT: The XL and XXL models use a driveshaft housing spacer which will come off with the gear housing. Be careful not to drop or lose the driveshaft housing spacer on these models.

Gear Housing Installation

1. On right-hand rotation gearcases, use the shift shaft tool to rotate the shift shaft counterclockwise into the front (forward) gear. For left-hand rotation gearcases, use the shift shaft tool to rotate the shift shaft clockwise into the front (reverse) gear.

NOTE: It may be necessary to rotate the propeller shaft to ensure that the clutch is engaged.

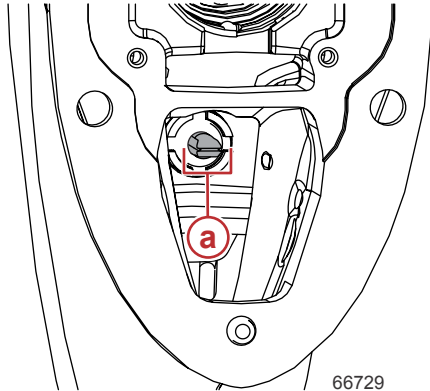

a - Shift shaft in neutral position

Shift shaft handle tool	8M0127025
-------------------------	-----------

2. Ensure that the notch on the shift shaft coupler aligns with the notch on the shift actuator output shaft.

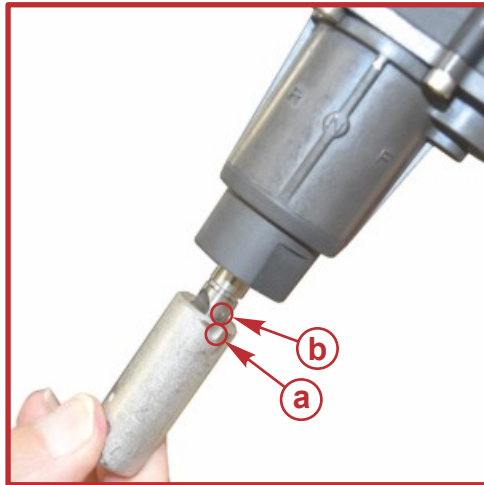

a - Notch on shift actuator coupler
b - Notch on shift actuator output shaft

65132

THE INFORMATION IN THIS DOCUMENT IS CONFIDENTIAL AND PROTECTED BY COPYRIGHT AND IS THE PROPERTY OF MERCURY MARINE.

This document is provided for the sole and exclusive use of the original recipient as prescribed by Mercury Marine and may not be distributed or copied, digitally or otherwise, without the prior written consent of Mercury Marine.

- On right-hand rotation gearcases, use a 15 mm wrench to rotate the shift actuator coupler so the notch on the coupler is aligned with the "F" marking on the shift actuator. For left-hand rotation gearcases, use a 15 mm wrench to rotate the shift actuator coupler so the notch on the coupler is aligned with the "R" marking on the shift actuator.

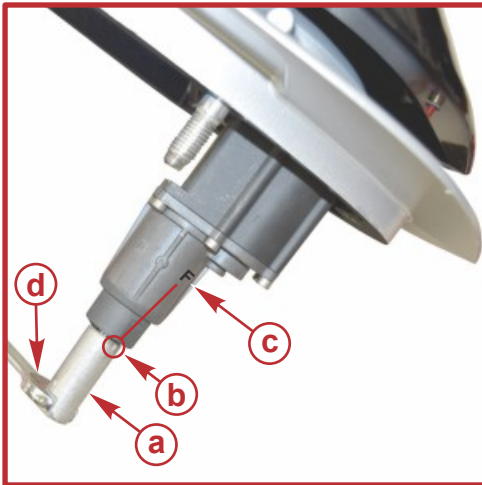

65127

- a - Shift actuator coupler
- b - Tab on shift actuator coupler
- c - "F" marking on shift actuator
- d - Wrench

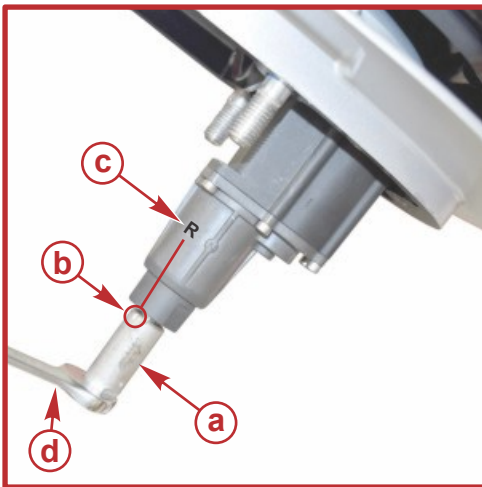

65128

- a - Shift actuator coupler
- b - Tab on shift actuator coupler
- c - "R" marking on shift actuator
- d - Wrench

- Position the gear housing and spacer if equipped, so the driveshaft is protruding into the driveshaft housing.
- Move the gear housing up toward the driveshaft housing while aligning the water pump coupler to the water tube and the shift shaft into the shift shaft actuator coupler.

NOTE: If the driveshaft splines will not align with the crankshaft splines, rotate the propeller shaft slightly to reposition the splines.

- Secure the gear housing assembly to the driveshaft housing.

THE INFORMATION IN THIS DOCUMENT IS CONFIDENTIAL AND PROTECTED BY COPYRIGHT AND IS THE PROPERTY OF MERCURY MARINE.

This document is provided for the sole and exclusive use of the original recipient as prescribed by Mercury Marine and may not be distributed or copied, digitally or otherwise, without the prior written consent of Mercury Marine.

Special Tools

Rigging

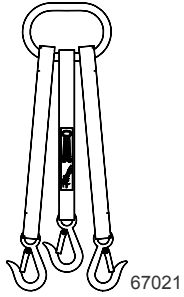
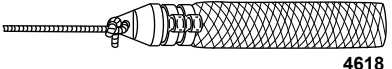
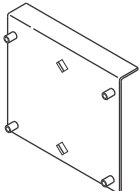
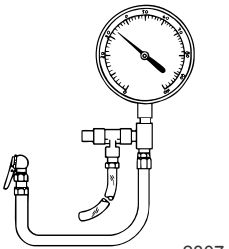

<p>Lifting Strap</p>  <p>67021</p>	<p>883705T01</p> <p>Use with an overhead hoist to lift an engine.</p>
<p>Data Cable Puller</p>  <p>4618</p>	<p>888462A 1</p> <p>Attaches to end of the DTS data harness to aid in pulling harness through boat. Prevents damage to the DTS data harness.</p>
<p>Transom Drilling Fixture</p>  <p>5489</p>	<p>91- 98234A 2</p> <p>Aids in engine installation by acting as a template for engine mounting holes.</p>
<p>Fuel Pressure Gauge Kit</p>  <p>2807</p>	<p>91-881833A03</p> <p>Tests the fuel pump pressure; can be used to relieve fuel pressure.</p>

THE INFORMATION IN THIS DOCUMENT IS CONFIDENTIAL AND PROTECTED BY COPYRIGHT AND IS THE PROPERTY OF MERCURY MARINE.

This document is provided for the sole and exclusive use of the original recipient as prescribed by Mercury Marine and may not be distributed or copied, digitally or otherwise, without the prior written consent of Mercury Marine.

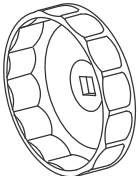

Battery/Clean Power Service Tool Harness	91-8M0147078
	<p>The harness is specifically designed to assist with the outboard engine installation onto the boat transom. When the battery/clean power service tool harness is installed, use the cowl mounted trim switch to change the transom brackets/mount cradle angle so it is better aligned—parallel with the boat transom. The battery/clean power service tool harness can be used on any outboard or MerCruiser power package which utilizes a clean battery power source.</p>

Maintenance

Crankcase Oil Pump	802889A1
	<p>Aids in the removal of engine oil without draining the crankcase.</p>
Oil Drain Hose	8M0129230
	<p>Aids in the removal of engine oil without draining the crankcase. Connect to the crankcase oil pump.</p>
Oil Filter Wrench	91-889277
	<p>Aids in the removal of the oil filter. Cup size: 76mm x 14 flute.</p>

THE INFORMATION IN THIS DOCUMENT IS CONFIDENTIAL AND PROTECTED BY COPYRIGHT AND IS THE PROPERTY OF MERCURY MARINE.

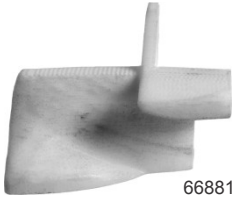
This document is provided for the sole and exclusive use of the original recipient as prescribed by Mercury Marine and may not be distributed or copied, digitally or otherwise, without the prior written consent of Mercury Marine.

Alternator Belt Shoe	8M0146862
 <p>66881</p>	<p>Aids in the installation and removal of the alternator belt on V-8 and V-6 FourStroke outboards. Tool ID number 8M0140323.</p>
Flywheel Rotation Tool	8M0146861
 <p>66882</p>	<p>Aids in the manual rotation of the flywheel, especially for alternator belt removal and installation. Tool ID number 8M0144583.</p>

Diagnostic Tool Requirements

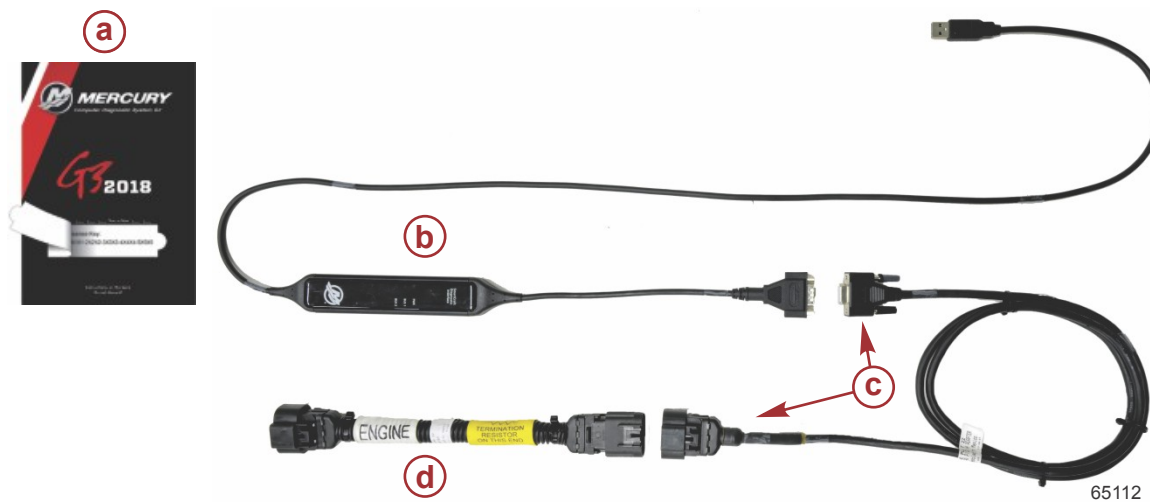

- a**- Mercury Marine CDS G3 license key
- b**- CDS G3 SmartCraft diagnostic interface
- c**- CAN-P/CAN-H adapter harness
- d**- G3 engine harness adapter with resistor

Description	Part Number
CDS G3 interface kit	91-8M0138392
Mercury Marine CDS G3 2018 license key	90-8M0138391

The V-8 200–300 and V-6 175–225 FourStroke outboards require CDS G3 2018 update 3 or greater. Along with the standard data fault support in this version/update, the following active diagnostics are also supported for this outboard:

- Injector pulse test
- Ignition spark gap test
- Tachometer output test
- Fuel pump output test
- IAC output test

THE INFORMATION IN THIS DOCUMENT IS CONFIDENTIAL AND PROTECTED BY COPYRIGHT AND IS THE PROPERTY OF MERCURY MARINE.

This document is provided for the sole and exclusive use of the original recipient as prescribed by Mercury Marine and may not be distributed or copied, digitally or otherwise, without the prior written consent of Mercury Marine.

- Horn output test
- Cylinder misfire test
- Smart start test

To connect the CDS G3 SmartCraft interface cable to the engine, you must remove the yellow resistor cap from below the electrical box cover and replace it with the SmartCraft interface adapter harness P/N 8M0046081. The adapter harness contains the proper termination for the CAN bus circuit. Proper termination is required to ensure reliable communication. The adapter allows the SmartCraft diagnostic interface to connect directly to the 10-pin connector on the engine.

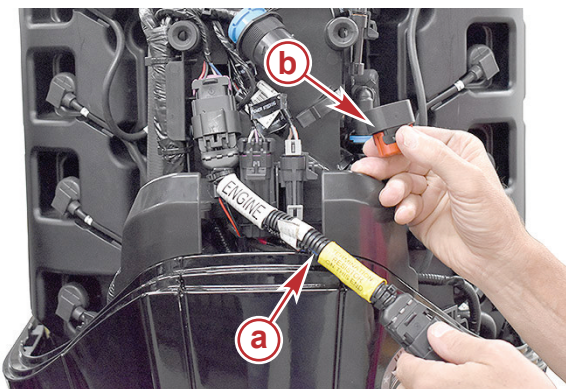

67689

- a** - SmartCraft diagnostic interface adapter with resistor P/N 8M0046081
- b** - Resistor cap from engine

Adaptive Speed Control Propping with CDS G3

A special propping procedure using CDS G3 should be used for optimum propping. An informative video can be found at: <https://p.widencdn.net/v7mcw2/ASC-Propping>.

1. Install the best guess propeller.
2. Connect CDS G3 to the engine, and monitor the following values:
 - **RPM** - engine speed. In this example, for a new boat with a new engine, the ideal RPM is at the upper end of the RPM range.
 - **DemandLinear** - requested handle position. This should be at 100% at wide-open throttle. If this value is not at 100% when the handle is in the full forward position, the throttle cable needs to be adjusted—mechanical engine, or the helm configuration needs to be performed—DTS engine.
 - **DemandLinear_with_Guardian** - software controlled limit with any engine protection/Guardian limits applied. This value should also be at 100% when underway and with the handle in the full forward position. If this value is less than the **DemandLinear** value, check faults for Guardian cause and correct the issue.
 - **Demand** - the final demand value requested by the software. If the engine is propped correctly, with engine speed at wide-open throttle falling within the operating range at optimum trim, this value should be at 100%.

STBD Engine - City ID: 11		
NAME	VALUE	DESCRIPTION
RPM	5212 RPM	Engine speed
Demand	100.00 %	Demand request by control software
DemandLinear_with_Guardian	100.00 %	Demand request by Guardian
TrimPospercent	19.35 %	Trim Position
DemandLinear	100.00 %	Demand request by operator

65614

3. Run the engine with the handle at wide-open throttle (100% DemandLinear) at optimum trim. Use the following chart to aid in final propeller selection.

THE INFORMATION IN THIS DOCUMENT IS CONFIDENTIAL AND PROTECTED BY COPYRIGHT AND IS THE PROPERTY OF MERCURY MARINE.

This document is provided for the sole and exclusive use of the original recipient as prescribed by Mercury Marine and may not be distributed or copied, digitally or otherwise, without the prior written consent of Mercury Marine.

Scenario	Engine Speed—See Note 1				
	Description	< 5,200 RPM	At or just above 5,200 RPM	Within operating range	At or just below 6,000 RPM
DemandLinear = 100% DemandLinear with Guardian = 100% Demand = 100%	Decrease propeller pitch until engine speed falls within operating range.	Consider a slightly lower pitch propeller. See Note 2.	No change needed.	Consider a slightly higher pitch propeller. See Notes 3 and 4.	N/A
DemandLinear = 100% DemandLinear with Guardian = 100% Demand < 100%	N/A	N/A	N/A	N/A	Increase propeller pitch until engine speed falls within operating range.
DemandLinear < 100% with throttle lever at maximum	Adjust throttle cable or reconfigure DTS handle so that 100% DemandLinear can be reached.				
DemandLinear = 100% DemandLinear with Guardian < 100%	Check faults for cause of Guardian condition.				

Notes from the Table:

1. The range of 5,200–6,000 RPM is an example only. Actual RPM ranges vary by model. Refer to the applicable specifications for your particular engine model.
2. Lowering the pitch of the propeller will increase the engine speed above the 5,200 RPM lower threshold, to account for variations in loading and ambient conditions.
3. Increasing the pitch of the propeller will decrease the engine speed below the 6,000 RPM upper threshold, to account for variations in loading and ambient conditions.
4. Demand may be slightly less than 100%.

Adaptive Speed Control Propping without CDS G3

IMPORTANT: Boat propping can be performed using the normal method used for Mercury Outboards. To achieve optimum propeller selection, however, follow the Adaptive Speed Control Propping with CDS G3 procedure.

IMPORTANT: To operate the engine at full throttle before the break-in period is complete, follow this procedure.

1. Start the engine and shift into forward gear.
2. Slowly advance the throttle until the engine reaches 1300 RPM (± 100 RPM).
3. Watch all gauges for normal readings.
4. When the engine reaches normal operating temperature, run the boat up on plane.
5. Advance the engine RPM—in 200 RPM increments, until the engine reaches its maximum rated RPM. Refer to the appropriate outboard owner’s manual or service manual for the engine’s full throttle RPM range.
6. To test if the correct propeller has been installed, operate the boat (with normal load onboard) at WOT and check RPM with an accurate tachometer. The engine RPM should be near the top of the specified range so that, under a heavy load, the engine speed will not fall below specifications. If the engine speed is too high, replace the propeller with a higher pitch propeller. Normally a 25 mm (1 in.) propeller pitch change causes an RPM change of 150 RPM.
7. Return to idle speed.
8. Shut off the engine.

Operational Note

Depending on the model version CMS or AMS, a noticeable noise may be emitted from the outboard’s electronic actuators during a key off, tilt switch actuation. To allow the outboard to be tilted with the key in the off position, the PCM is momentarily turned on with the tilt switch. When the PCM turns on, the actuators will cycle and create a clicking or a buzzing sound. The noise created by this actuator cycling is considered normal operation.

THE INFORMATION IN THIS DOCUMENT IS CONFIDENTIAL AND PROTECTED BY COPYRIGHT AND IS THE PROPERTY OF MERCURY MARINE.

This document is provided for the sole and exclusive use of the original recipient as prescribed by Mercury Marine and may not be distributed or copied, digitally or otherwise, without the prior written consent of Mercury Marine.