



MERCRUISER SERVICE BULLETIN

Section: 12 (Bulletins)

Number: 66-113

Date : 9/1/66

Cut individual items along broken lines and attach in appropriate sections of your MerCruiser Service Manual.

- A. Serial Number Location - All MerCr. Stern Drives (Section 1)
- B. Exhaust Bellows Installation Tool - MerCruiser I (Section 11)
- C. Cylinder Head Wedge - MerCruiser "60" (Section 11)
- D. Universal Joint Assembly - All MerCruiser Models (Section 9)

A. SERIAL NUMBER LOCATION - ALL MERCUISER DRIVE UNITS

(For General Information Section 1)

All MerCruiser drive units, which presently are in production, have the serial number stamped into the decal located on the port side of the drive shaft housing and also stamped into the casting under the decal.

B. EXHAUST BELLOWS INSTALLATION TOOL - MERCUISER I

(For Tool Section 11)

The Exhaust Bellows Expander Tool (C-91-45497A1) has been developed to aid in installing the exhaust bellows to the bell housing on all MerCruiser I drive units. Use the tool as follows:

1. Place exhaust bellows expander into bell housing exhaust outlet. (Figure 1)
2. Push handles of tool together, thus causing inner end to expand and catch in the first convolution of the bellows, then install the holding clip into handles. (Figure 2)

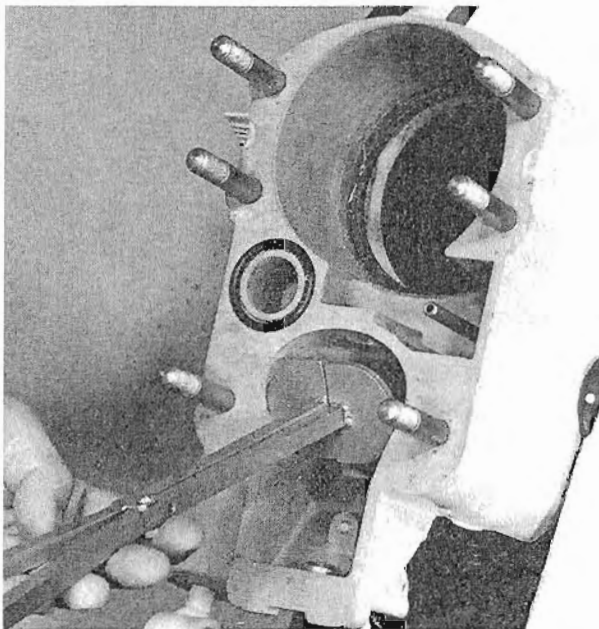

Figure 1. Tool Placed in Bell Housing Exhaust Outlet

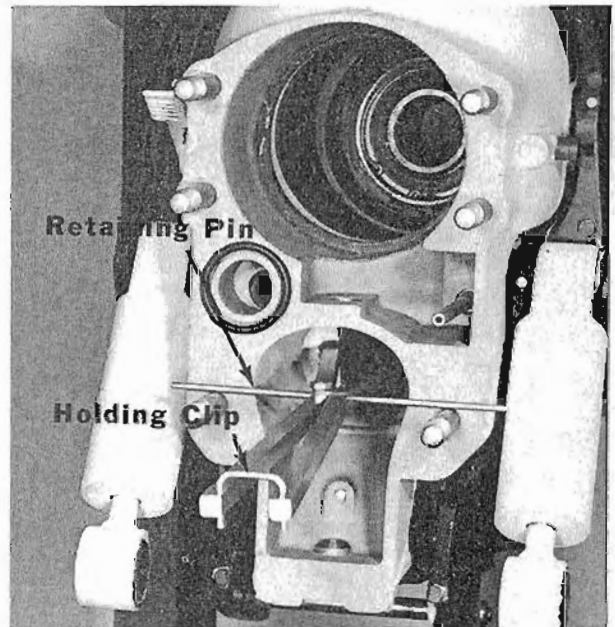

Figure 2. Installing Holding Clip into Tool Handles

3. Pull out on tool to pull bellows over flange on bell housing and place retaining pin thru tool, allowing retaining pin to rest on bell housing. (Figure 2)
4. Place clamp on bellows and remove tool.

C. CYLINDER HEAD WEDGE - MERCUISER "60"

(For Tool Section 11)

A new aluminum wedge (C-91-37023) can be used when making repairs on MerCruiser "60" cylinder head assemblies. The wedge holds the head in a position so that valve guides are in a vertical position for replacement. Refer to MerCruiser Service Manual Section 8 for proper use of the tool. (Figures 3 and 4)

Install the cylinder head on the wedge with four 96mm cylinder head to cylinder block screws.

C-91-37023

Wedge, MerCruiser "60" Cylinder Head

\$ 12.00 Net U.S.

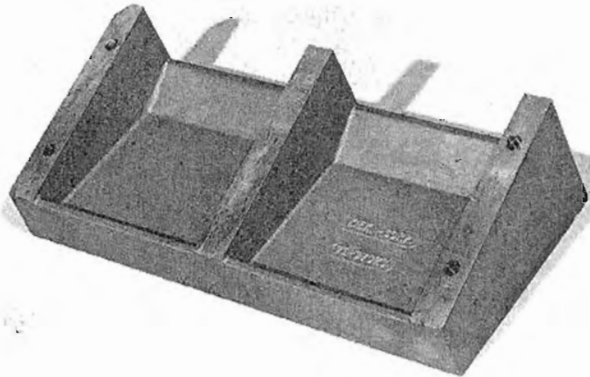

Figure 3. Wedge for MerCruiser "60" Cylinder Head Repair

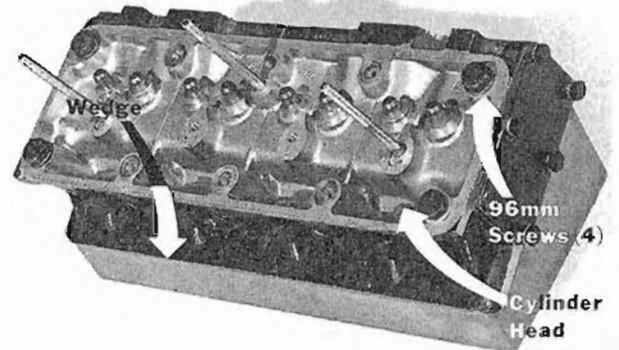

Figure 4. Cylinder Head in Position on Wedge

D. UNIVERSAL JOINT ASSEMBLY - ALL MERCUISER MODELS

(For Drive Unit Section 9)

The 4 parts, which make up the universal joint assembly for MerCruiser Stern Drives, now can be ordered separately for service replacement. See Figure 5 and order from chart below.

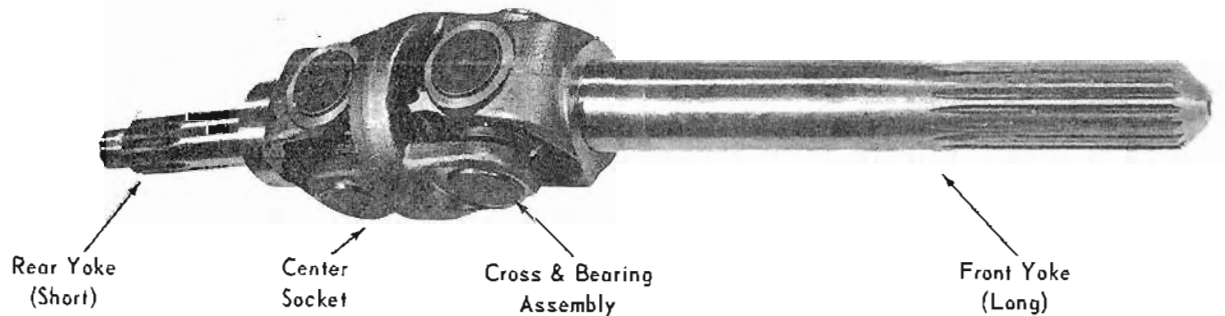

Figure 5. Universal Joint Assembly Components

	Universal Joint	Rear Yoke (Short)	Center Socket	Cross & Bearing Assembly (2 Req.)	Front Yoke (Long)
MerCr. "O"	B-38124	B-39413	B-39409	B-36311	B-39412
MerCr. I	B-32595	N.A.	N.A.	B-36311	N.A.
MerCr. IA-B-C & E-Z	B-35911A1	B-39384	B-39383	B-36312	B-39385A1
MerCr. IB-C (1967)	B-45808A1	B-46020	B-39383	B-36312	B-39385A1
MerCr. II *	B-32051	N.A.	N.A.	B-36312	B-39496
MerCr. II **	B-36013	B-39495	B-39383	B-36312	B-39496

* Serial No. 1602185 & below

** Serial No. 1602186 & above

N. A. = Not available