

TO: SERVICE MANAGER TECHNICIANS
PARTS MANAGER

No. 80-8

Power Trim Hose Installation to Reverse Lock Valve

(Attach Bulletin Reference Sticker to P. 7A-8 of Your Service Manual.)

Some V-8 engines (898/228/260) reverse lock valve assemblies were produced with an extra seal plug (Figure 1) in straight fitting to which white plastic tubing connects. This plug must be removed, along with shipping plug and ball.

If plug is not removed, Power Trim will not operate hydraulically in “up” or “down” direction. Future reverse lock valve assemblies again will have only the shipping plug and ball installed.

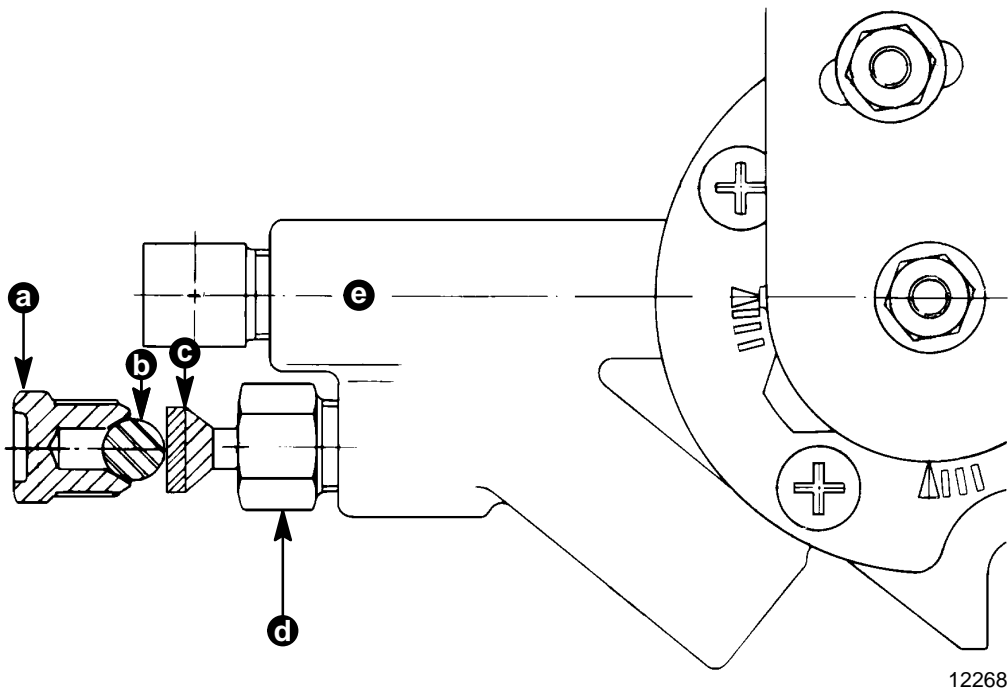

- a - Shipping Plug
- b - Ball
- c - Extra Seal Plug
- d - Straight Fitting
- e - Reverse Lock Valve Assembly

Figure 1. Seal Plug Location

V-8 Power Steering Locking Spring

(Attach Bulletin Reference Sticker to P. 2C-8 of Your Service Manual.)

When servicing V-8 Power Steering that does not have a locking spring (24-78498) installed on its mounting tube, install one of the locking springs during reinstallation of the Power Steering assembly to transom. (Figure 2)

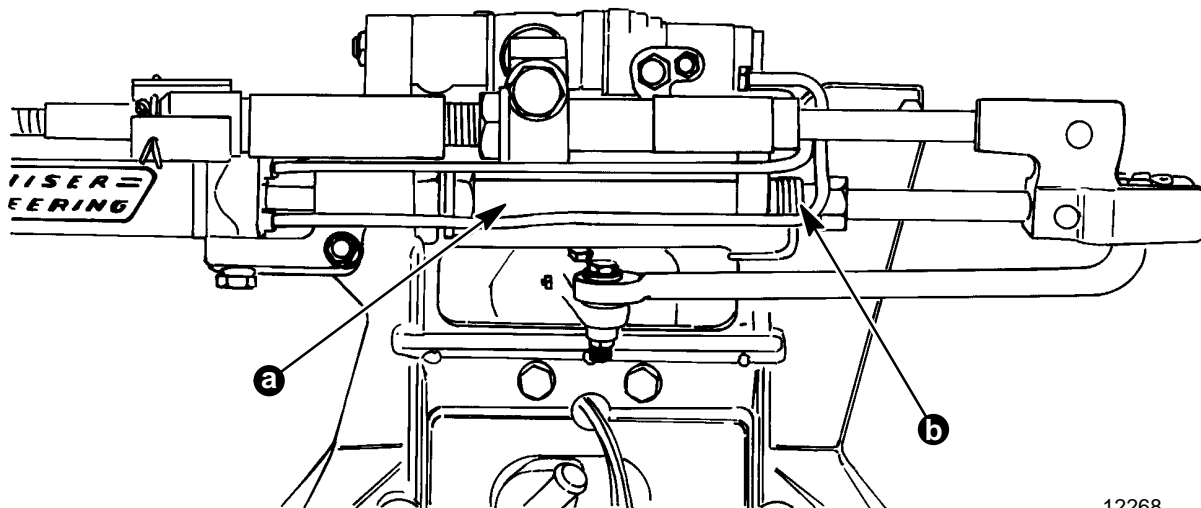

12268

- a - Power Steering Mounting Tube
- b - Locking Spring

Figure 2. V-8 Power Steering with Locking Spring

Propeller Installation

(Attach Bulletin Reference Sticker to PP. 2A-4, 2B-5 and 2C-6 of Your Service Manual.)

When installing a MerCruiser propeller, the splines of the splined washer must engage splines of propeller shaft, or propeller nut may come off. Propeller should be pushed onto propeller shaft far enough so that spline engagement can be felt when spline washer is installed. Torque nut to a minimum of 55 ft. lbs. (7.6 mkg). Retorque after first use and check periodically for tightness.

If spline engagement cannot be felt, propeller hub is not installed correctly. Problem can be corrected by having a Quicksilver Propeller Repair Station remove the hub and install a NEW hub.

External Return Line Trim Cylinder Repair Kits

(Attach Bulletin Reference Sticker to P. 7A-15 of Your Service Manual.)

Repair kits and parts for the new external return line trim cylinders now are available. Part numbers are as follows:

MerCruiser Model	II-TR/TRS	120-thru-260
Overhaul Kit	B-86611A1	B-87068A1
Seal Kit	B-25-79871A1	B-25-60342A3
Tube, Outer (stb.)	B-87412	B-87173
Tube, Outer (port)	B-87411	
Cap, End	B-88035	B-87069

MerCathode Installation with Dual Drive Units

(Attach Bulletin Reference Sticker to P. 7E-2 of Your Service Manual.)

When installing a MerCathode on a boat with dual drive units (Figure 3), the anode is installed between the drives (below waterline), and the reference electrode is installed on outside of either drive (below waterline). This location will protect both drive units.

When installing two (2) MerCathode systems on a boat with dual drive units (Figure 4), both anodes are installed between the drives (below waterline), and reference electrodes are installed on outside of each drive unit (below waterline).

On all MerCruiser Power Packages, the drive, transom assembly, engine and battery MUST have a common ground (be grounded together). On dual installations, the two Power Packages must be grounded together. This is easily done with a ground strap between engine blocks or between negative (-) battery terminal. Both Power Packages must be grounded to the negative (-) terminal of battery to which the MerCathode system is connected.

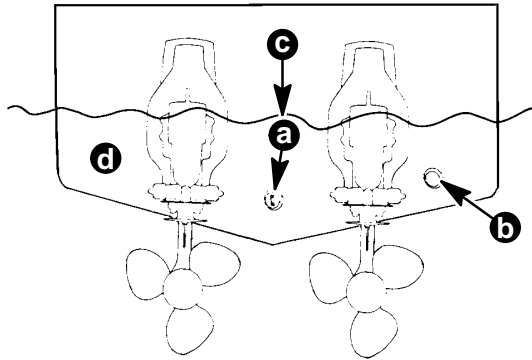

- a - Anode
- b - Reference Electrode Location
- c - Waterline
- d - Alternate Reference Electrode Location

Figure 3. Dual Drive Installation with Single MerCathode

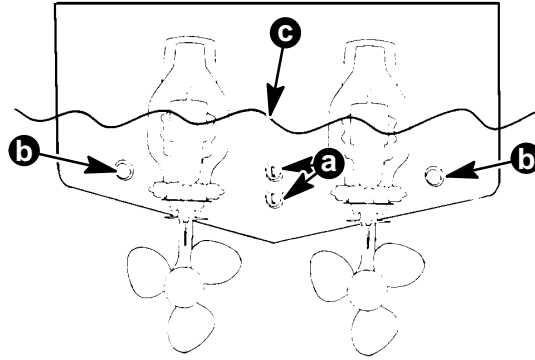

- a - Anodes (2)
- b - Reference Electrode (2)
- c - Waterline

Figure 4. Dual Drive Installation with Dual MerCathode

Testing for Need of Two MerCathodes

Use Test Tool C-76675A1 Reference Electrode in conjunction with Quicksilver VOA Meter C-91-62562A1. (Quicksilver VOA Meter also is part of Quicksilver Thunderbolt Ignition Analyzer C-91-62563A1.)

Testing Instructions

1. Plug Reference Electrode lead into POSITIVE (+) receptacle of VOA meter.
2. Plug negative lead into NEGATIVE (-) receptacle of VOA meter and connect lead to negative battery terminal or other convenient ground.
3. Set meter dial on "AUX. TEST" position.
4. Immerse Reference Electrode in water near drive.
5. Read 0-20 (bottom) scale:

IMPORTANT: NEW boats, just placed in service (with or without MerCathode), almost always will produce a reading higher than 9.4 (940 millivolts equivalent). This is because the drive is protected by a good finish paint job and new sacrificial zinc anodes. To obtain an accurate diagnosis, the reading should be taken sometime after the boat has been in service for anywhere from one to 2 weeks. After this time, the paint has had a chance to "soak", and minor abrasions and scratches in the finish will have appeared, thus a more accurate reading.

- a. A reading between 9.4 (940 millivolts equivalent) and 10.5 (1050 millivolts equivalent) indicates that the drive and hull are cathodically protected.
 - b. A reading of 8.6 (860 millivolts equivalent) is acceptable, if the drive is equipped with a stainless steel or bronze propeller.
6. If the boat is equipped with a MerCathode, and the reading is BELOW 9.4 (940 millivolts equivalent), except in "b" preceding, use the Corrosion Troubleshooting Chart (MerCruiser Service Bulletin 80-7) to be sure that MerCathode is installed properly, functioning properly and that there are no outside factors causing galvanic corrosion beyond the capability of any MerCathode System, such as stray 12-volt current, improper shore power supply, large unprotected steel hull, etc.

After everything is checked OK, and reading is still low, a second MerCathode may be needed.

Ride-Guide Steering Cable Measurement

(Attach Bulletin Reference Sticker to P. 2D-2 of Your Service Manual.)

Ride-Guide Cable Measurement - Straight Rack

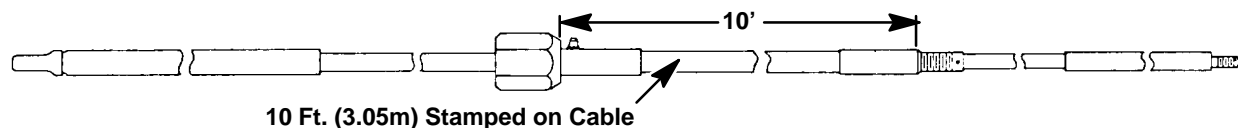

Figure 5. Old Method of Measuring (34451A10 Cable)

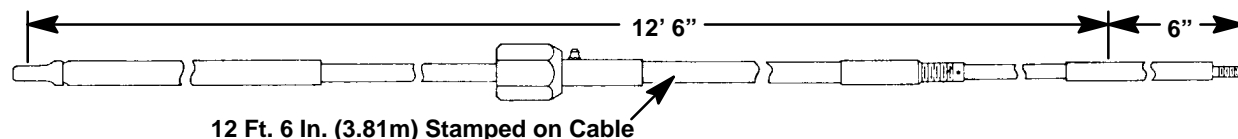

Figure 6. A.B.Y.C. Method of Measuring (76043A12 Cable)

Example: 34451A10 cables were measured the old way (from cable fastening nut to 9/16 x 18 threaded end) and had old measurement (10 ft.) stamped on cable housing. This cable would be interchangeable with 76043A12 cable which is measured the A.B.Y.C. way (from centerline of steering wheel to hole in output end of ram with steering at mid-travel) and has new measurement (12 ft. 6 in.) stamped on cable housing.

Ride-Guide Cable Measurement - Rotary

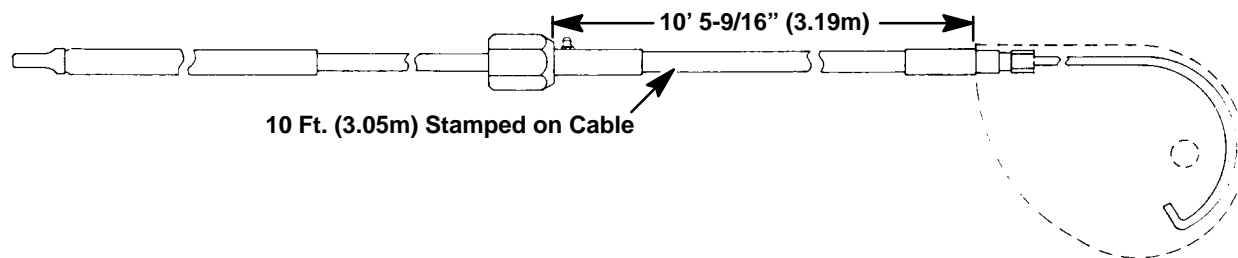

Figure 7. Old Method of Measuring (54121A10 Cable)

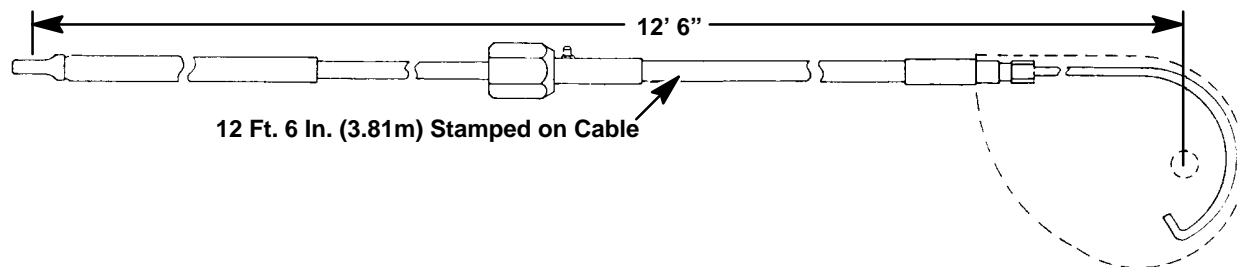

Figure 8. A.B.Y.C. Method of Measuring (76042A12 or 76876A12 Cable)

Example: 54121A10 cables were measured the old way (from cable fastening nut to housing) and had old measurement (10 ft.) stamped on cable housing. That cable is interchangeable with 76042A12 cable which is measured the A.B.Y.C. way (from centerline of steering wheel to hole in output end of ram with steering at mid-travel) and has new measurement (12 ft. 6 in.) stamped on cable housing.

Cable and head assembly 76876A is not interchangeable with 76042A__ or 54121A__, because of differences in head, however, both 76876 and 76042 cables are measured and stamped on cable housing by A.B.Y.C. standards.