

NUMBER: 85-33

NOTICE
This bulletin supercedes bulletin 83-7.

CIRCULATE TO:
SERVICE MANAGER
PARTS MANAGER
MECHANICS
"Place in a Service Bulletin Binder"

- A. MerCruiser Engine Identification - G.M. Engine Models (1974 and Newer)
- B. Cylinder Head Identification Marks - G.M. Small Block V-8 Engines (1980 and Newer)
- C. Mercury 4 Cylinder 224 CID Engine Identification - 470/485/488/170/190

A. MERCUISER ENGINE IDENTIFICATION - G.M. ENGINE MODELS (1974 and NEWER)

The MerCruiser Model can be determined by looking at the LAST TWO LETTERS of the engine code stamped into the cylinder block. (Figure 1) This code number is stamped on all MerCruiser Power Packages and replacement partial engines but not replacement cylinder block assemblies.

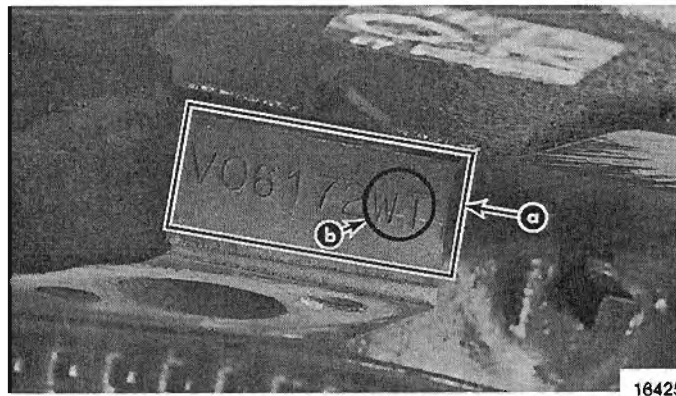

a - Engine Code (V06172WT),
b - Last Two Letters (WT)

Figure 1. G.M. Engine Code

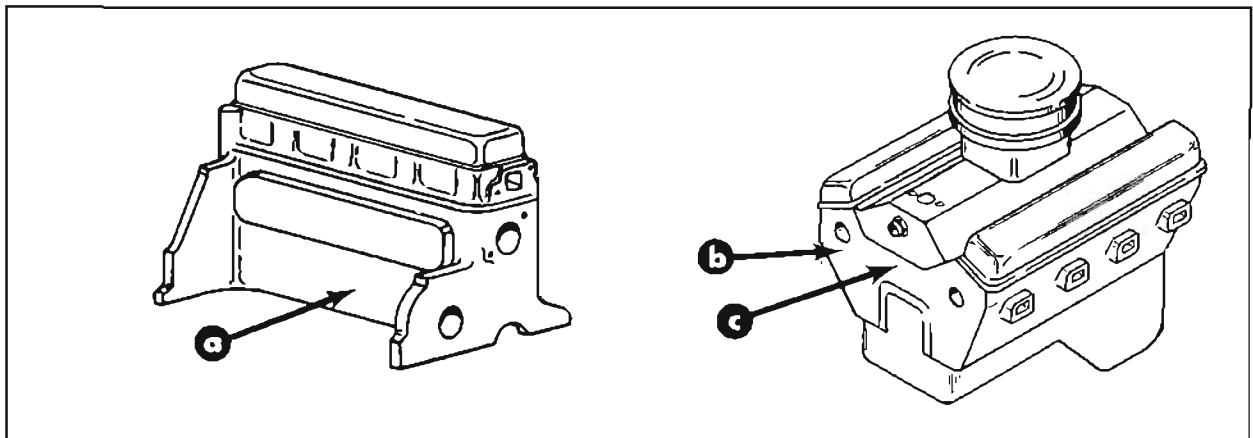

a - 4 and 6 Cylinder-In-Line (Near Distributor)
b - V-6 and Small Block V-8 (Front, Starboard Side, Near Cylinder Head Mating Surface)
c - Large Block V-8 (Front of Engine Just Above Timing Gear/Chain Cover)

Figure 2. G.M. Engine Code Location

If the engine serial number, and/or model decals are missing, the engine code letters may help in determining the engine model. Following is a list of G.M. engines and their respective code letters.

MCM Stern Drive Engines (All Are L.H. Rotation)

120 - NB	898/200 - MN/MX or PY	330 - XS
140 - RA	228/230 - MJ/MY or PZ	330 (B-W) - XY
165 - SD	250 - WS or WT	370/400/
185 (229 CI) - JK	255 - WH or WN	440/460
185 (262 CI) - KW	260 - WT or AN	475 Turbo
205 (262 CI) - KR	280/300 - WK	} XF

MIE Inboard Engines (Either Rotation)

L.H. (Standard) Rotation		R.H. (Opposite) Rotation	
198 - MR	260 - WN or AB	198 - MS	260 - WR or AR
228 - MA	330 - XN or XY	228 - MB	330 - XR or XZ
230 - MA or PA	340 - XY or XYY	230 - MB or PB	340 - XZ or XZZ
255 - WH or WN	350 - XB	255 - WJ or WR	350 - XC

B. CYLINDER HEAD IDENTIFICATION MARKS - G.M. SMALL BLOCK V-8 ENGINES (1980 and Newer)

The identification mark is located on both ends of the cylinder head.

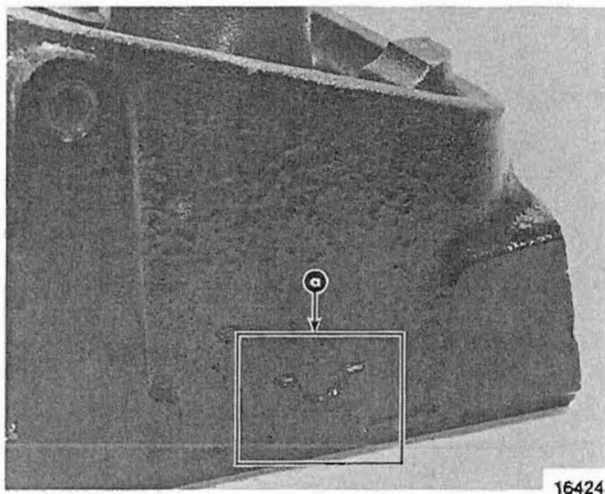

Figure 3. 305 CID Engines (898, 228, 230)

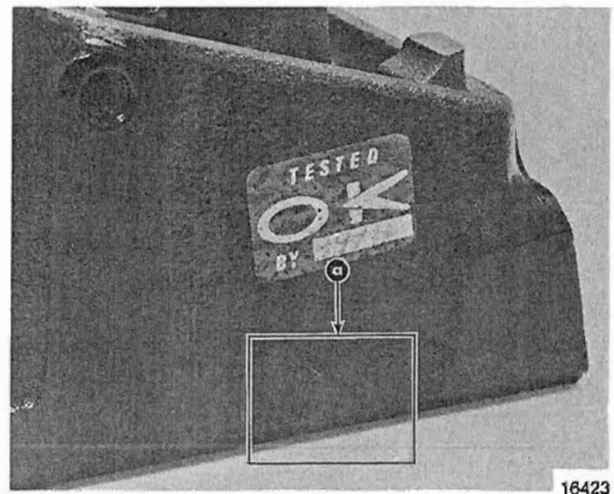
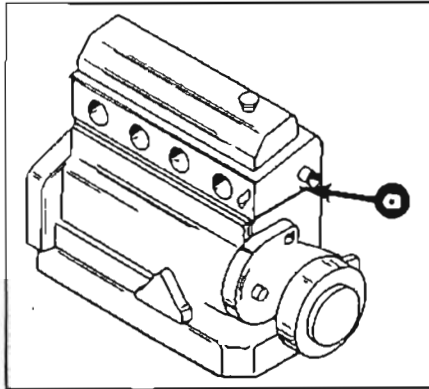

Figure 4. 350 CID Engines (255, 260)

C. MERCURY 4 CYLINDER 224 CID ENGINE IDENTIFICATION - 470/485/488/170/190

If the engine serial number and/or model decals are missing, the following will help in determining what model it is. Look for stamped code number in cylinder head. Also look at valve spring for color code.



a - "Stamped" Number

Figure 5. Location of Stamped Number

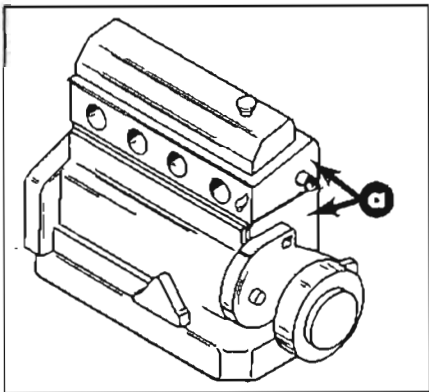

a - "X" Stamped on Both the Cylinder Head and Cylinder Block

Figure 6. Location of Identification

- | | |
|----------------------------------|---|
| MCM/MIE 470 (L.H.)
(Figure 5) | - Stamped "0" or no stamp at all in cylinder head. Single coil valve springs with orange stripe. |
| MIE 470 (R.H.)
(Figure 5) | - Same as above plus 1/4" thick ring between cylinder block and distributor. |
| MCM 485
(Figure 5) | - Stamped "5" in cylinder head. Valve springs have internal dampener and Red/Green or Blue/White stripes. |
| MCM 488
(Figure 5) | - Stamped "8" in cylinder head. Valve springs have external dampener around spring and Green stripe. |
| MCM 170/190
(Figure 6) | - Stamped "X" on both cylinder head and block. Same valve spring as 488 except dampener has anti-rotation tab |

NOTE: Refer To MerCruiser Service Bulletin 84-26 for replacement partial engines and cylinder heads used on the 470/485/488/170/190 engines.