

NUMBER: 84-26

CIRCULATE TO:  
SERVICE MANAGER   
PARTS MANAGER   
MECHANICS   
"Place in a Service  
Bulletin Binder"

- A. Supersession of Partial Engines and Cylinder Heads - MCM/MIE 470 and MCM 485/488
- B. Replacement Pistons - MCM 170MR/190MR

**A. SUPERSESION OF PARTIAL ENGINES AND CYLINDER HEADS - MCM/MIE 470 and MCM 485/488**

The partial engine assemblies of older Mercury Marine built engines has been superseded by one partial engine assembly (72775A16). MIE 470 (R.H.) partial engine assembly (72775A11) will not be affected by this supersession.

MCM 470: 72775A3  
MCM 470: 72775A10  
MIE 470 (L.H.): 72775A10  
MCM 485: 72775A12  
MCM 488: 72775A14

} SS to 72775A16 MCM 170MR/190MR Partial Engine Assembly

The MCM 170MR/190MR partial engine will be identified as shown in Figure 1.

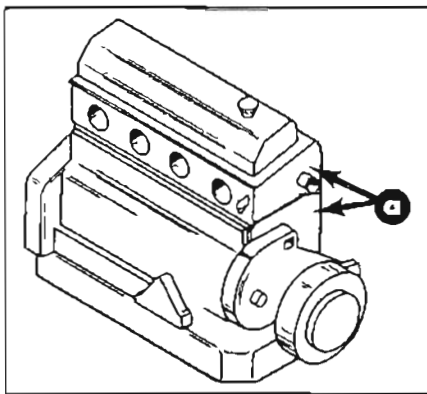

a - "X" Stamped on Both the Cylinder Head and Cylinder Block

**Figure 1. Location of Identification**

**IMPORTANT:** Replacement parts for the 72775A16 partial engine marked with an "X", as shown in Figure 1, must be ordered from the MCM 170MR/190MR parts list.

## CYLINDER HEADS

The cylinder head of older Mercury Marine built engines has been superseded by a complete cylinder head assembly (966-9187A3). This cylinder head assembly has the valves, springs, etc. installed.

MCM 470: 966-6187A4  
 MIE 470: 966-6187A4  
 MCM 485: 966-7704A3  
 MCM 488: 966-8551A2

} SS to 966-9187A3 MCM 170MR/190MR Cylinder Head Assembly

The MCM 170MR/190MR cylinder head assembly will be identified as shown in Figure 1.

**IMPORTANT: Replacement parts for the 966-9187A3 cylinder head assembly must be ordered from the MCM 170MR/190MR parts list.**

## B. REPLACEMENT PISTONS - MCM 170MR/190MR

Refer to the following chart when ordering pistons for the above model engines. Use this chart until parts lists are corrected. Refer to Service Bulletin 84-11 for installation and clearances.

	Part Number	MCM 170MR	MCM 190MR
<b>Figure 2</b>	759-8312A2 (Standard) 759-8312A3 (.005" O.S.) 759-8312-12 (.030" O.S.)	(Note 1)	(Note 2)
<b>Figure 3</b>	778-9015A2 (Standard) 778-9015A3 (.005" O.S.) 778-9015A4 (.030" O.S.)	(Note 1)	X

NOTE 1: Engine must use 4 of the same type of pistons.

NOTE 2: MCM 190MR uses only this type of piston.

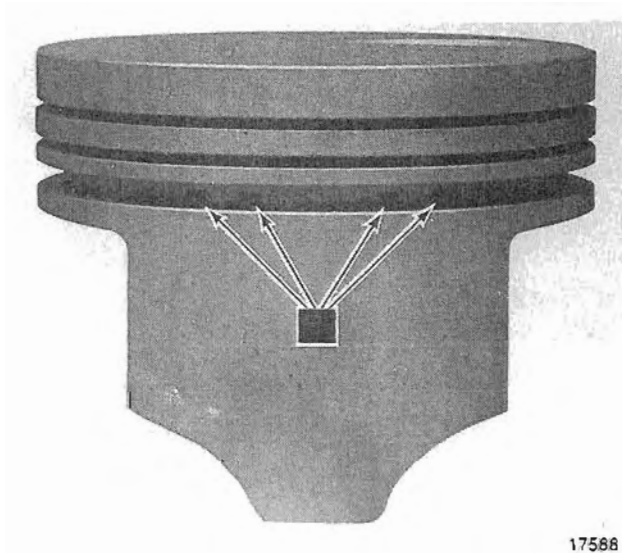
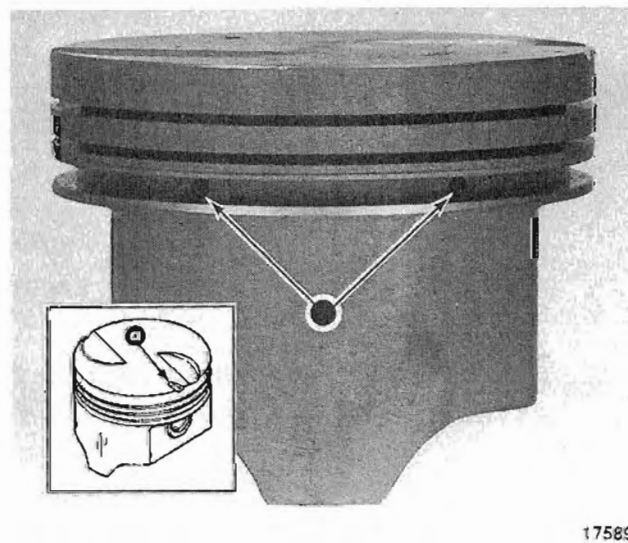

Figure 2.



a - Notch  
 Figure 3.