

CIRCULATE TO:
SERVICE MANAGER
PARTS MANAGER
MECHANICS
"Place in a Service
Bulletin Binder"

STEERING PIVOT BOLT INSTALLATION ON MERCURUISER 120-THRU-260 R & MR MODELS

If it is necessary to remove the Power Steering unit or manual steering swivel ring assembly, the following procedure should be used when reinstalling components to ensure proper installation. Failure to install components correctly could result in damage to the product and/or affect steering operation.

STEERING SYSTEM INSTALLATION

①

Inspect bushings (a) for debris. Lubricate with Special Lubricant 101 (b).

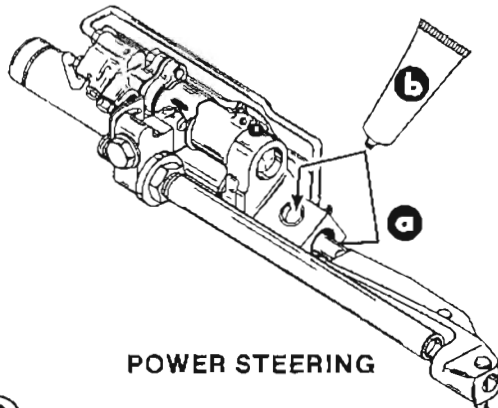
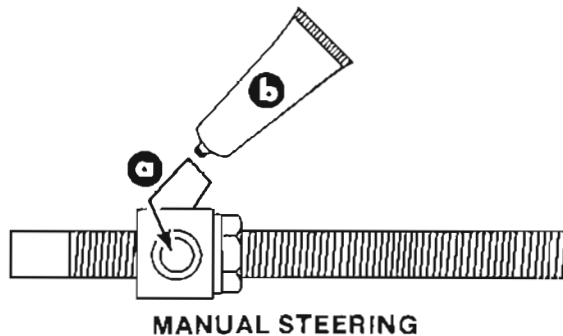

②

Lubricate pivot bolts with Special Lubricant 101.

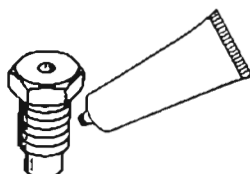

③

Install upper and lower pivot bolts as shown:

- First thread bolts (a) all-the-way in by hand to ensure proper alignment. Do not use a wrench.
- Tab washer tangs (b) must straddle ridge on inner transom plate.

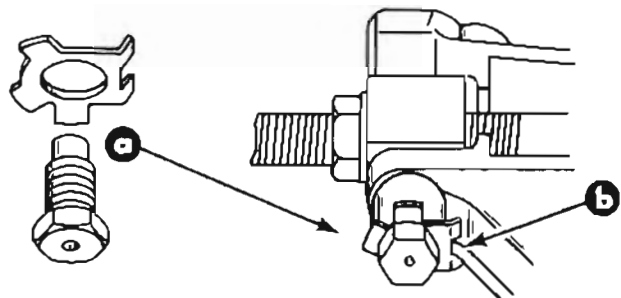
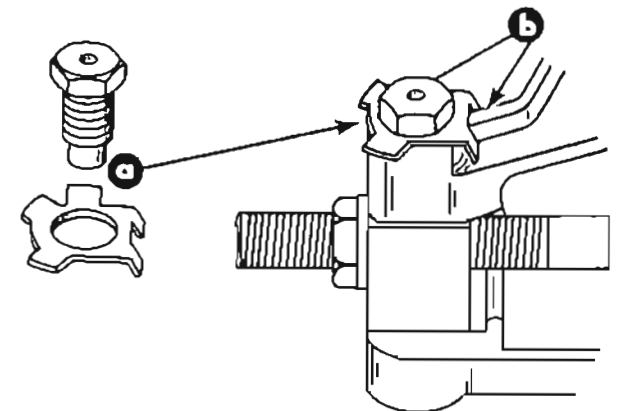

MANUAL STEERING

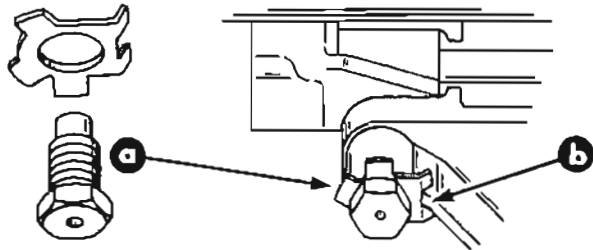
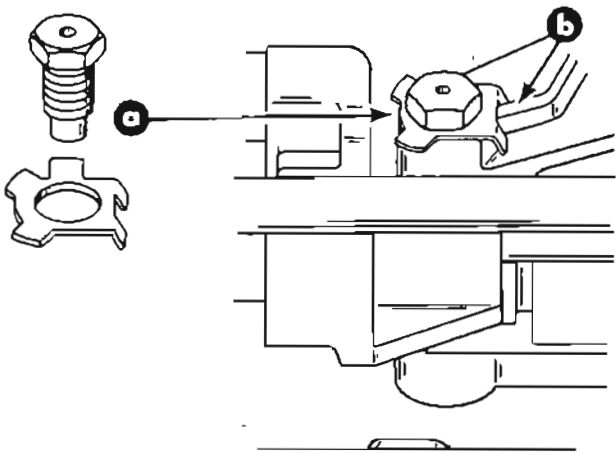

POWER STEERING

4

Torque bolts (a) to 25 lbs. ft. (34 N.m). Bend washer tabs (b) against corresponding flats on bolt heads.

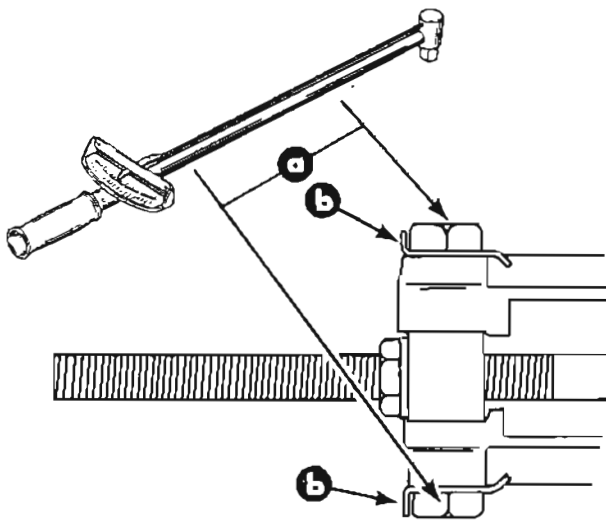

MANUAL STEERING

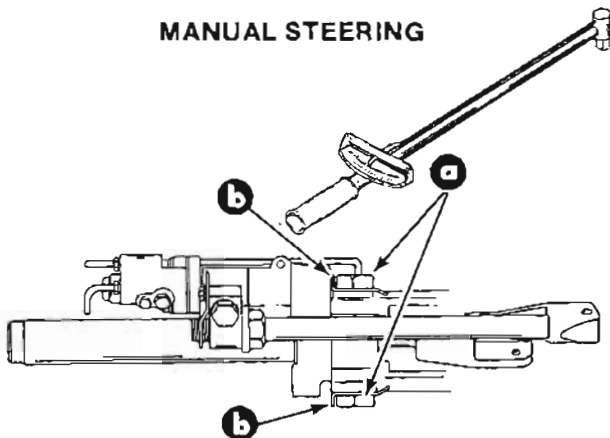

POWER STEERING

5

Check manual steering swivel ring assembly (a) to ensure that it pivots freely.

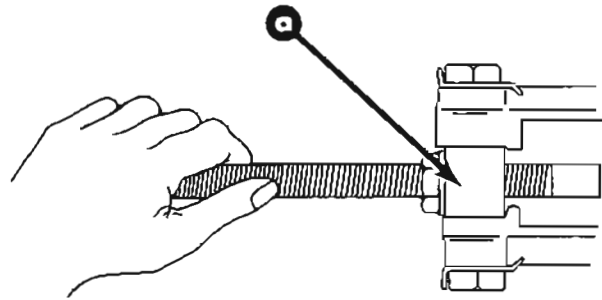

MANUAL STEERING

Check power steering unit (a) to ensure that it pivots freely.

Lubricate clevis pin (b) with Special Lubricant 101.

Connect power steering unit to steering lever. Install clevis pin from the top (b). Secure, spreading both halves of the cotter pin.

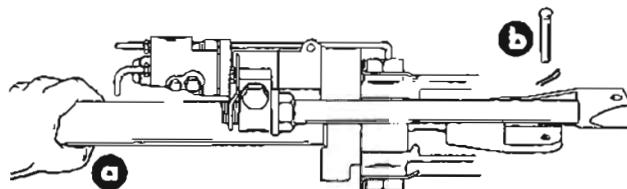

POWER STEERING

6

Reinstall steering cable.