

TO: SERVICE MANAGER TECHNICIANS
PARTS MANAGER

No. 88-2

Piston Knock in MCM 224 CID (3.7 Litre) Engines with Aluminum Exhaust Manifolds

There has been a few reports on the MerCruiser 224 CID 3.7 litre engines with aluminum exhaust manifolds having a piston knock caused by a tight piston pin. The starting serial numbers of engines with aluminum exhaust manifolds are 165/170 3.7L A528109 and up, 180/190 3.7 L/LX A528516 and up. The tight pin may be caused by engine coolant entering the cylinders because of a leaking exhaust elbow/reservoir to exhaust manifold gasket part number 27-97863. The early style 27-97863 gasket had a silicon seal on both sides. The later style 27-97863 gasket was changed to a graphite type (Figure 1). 27-97863 is now superseded to 27-18272 which is a graphoil/tin composite (Figure 1). Starting serial numbers of production engines, with the 27-18272 gaskets are 165 3.7L B742442 and up 180 3.7L/LX B743204 and up. Gasket part number 27-18272 is also in Quicksilver parts stock.

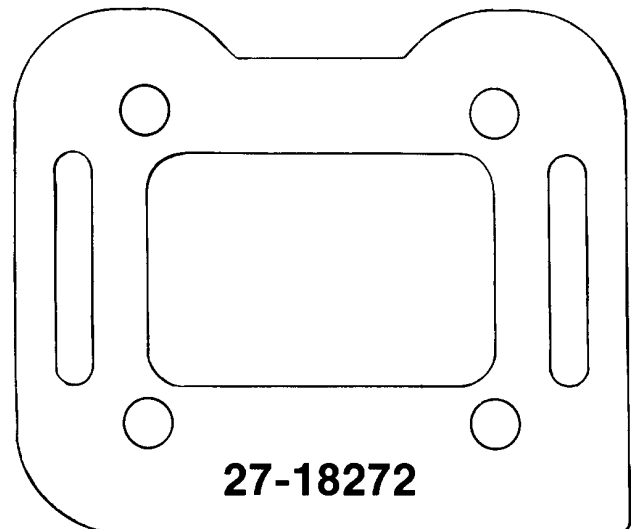
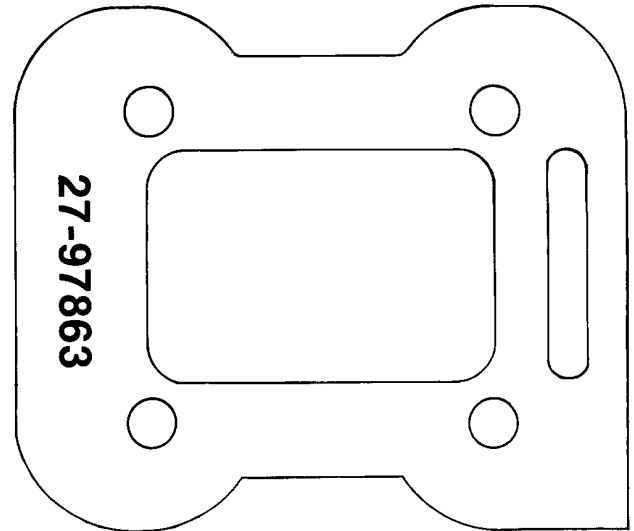
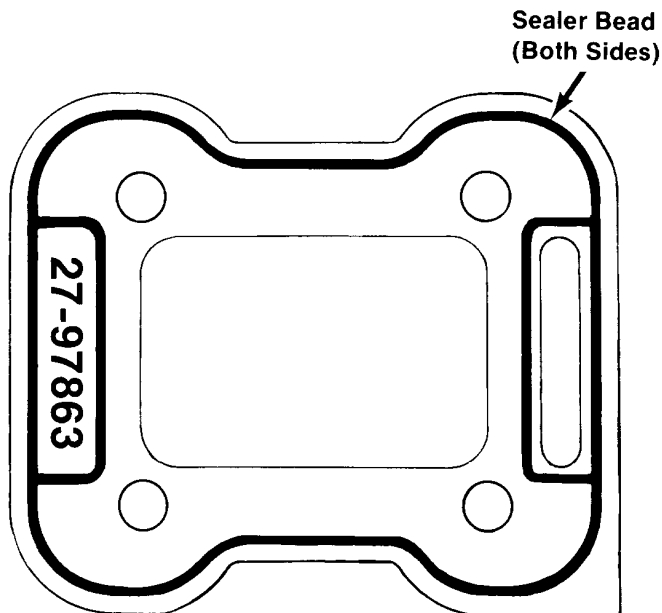

Figure 1.

Borg Warner V-Drive Oil Capacity Increase

Borg Warner V-Drive transmissions with dipstick located in V-Drive case (Figure 2) that have had intermediate shaft rear bearing failure should have oil capacity increased.

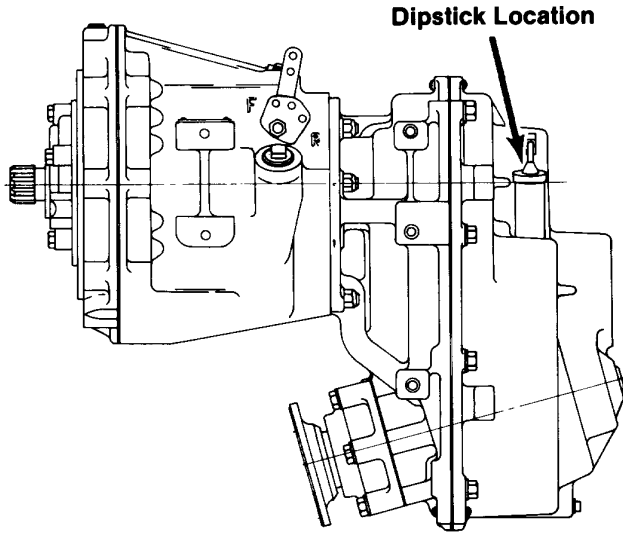

Figure 2.

Dipstick 10-05-559-001 (Figure 3) is now available for use in Velvet Drive® V-Drive transmissions which have the dipstick in the V-Drive case. The new dipstick will provide for additional oil capacity. Order new dipstick from your closest velvet drive distributor as shown on map. The following illustration shows the dimensions of the new dipstick. It is recommended that the new dipstick be installed when servicing any V-Drive transmission which has the dipstick located in the V-Drive case.

Original dipsticks can be modified to current design by adding a mark 1" (2.5mm) above the original "full" mark. The original "full" mark then becomes the "low" or "add oil" mark.

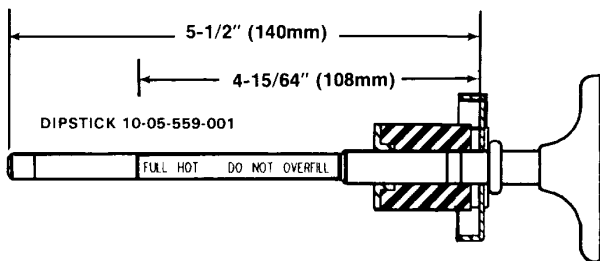
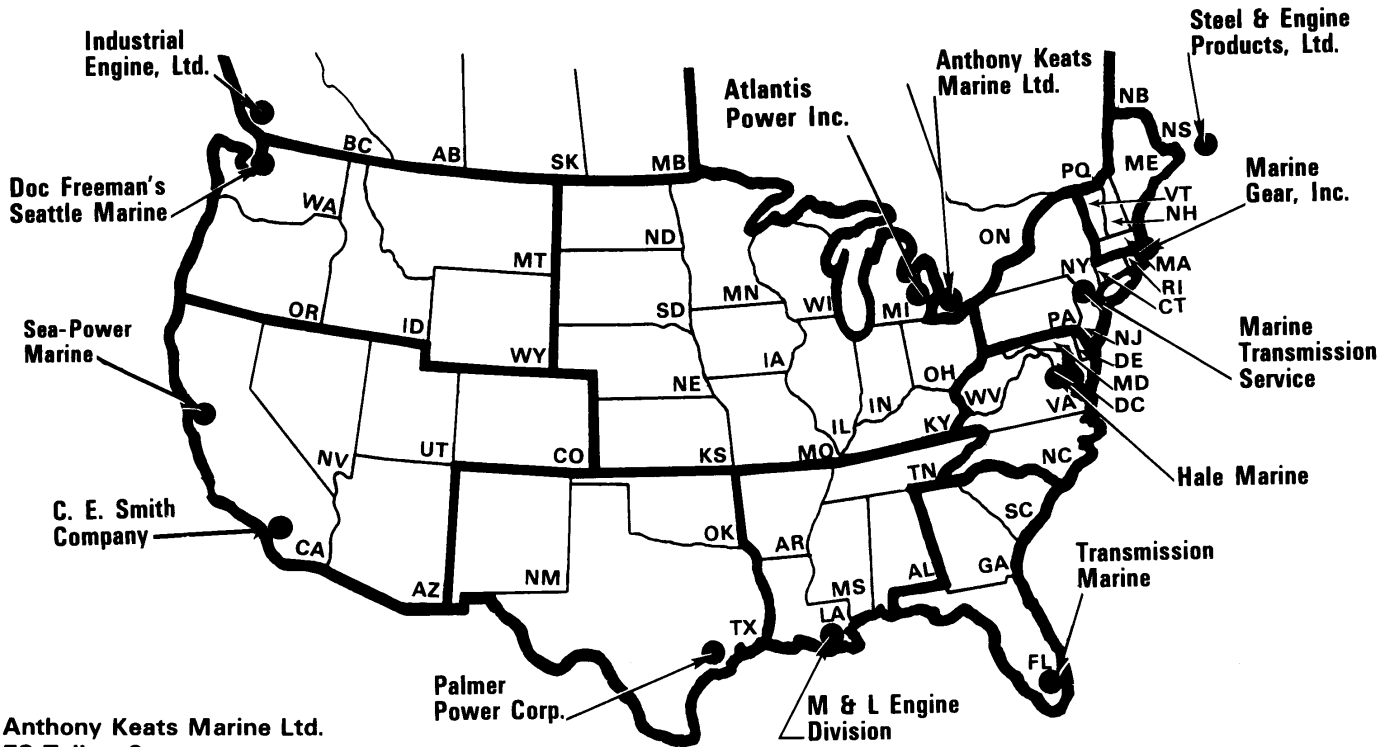

Figure 3.

The new dipstick has been installed in production transmissions beginning at the following serial numbers:

10-04-000-02	6473
10-04-000-03	1367
10-04-000-04	374
10-04-000-005	538
10-04-000-006	411
10-04-000-007	523
10-04-000-008	511
10-04-000-009	1201
10-04-000-010	809
10-04-000-011	7314
10-04-000-012	632
10-04-000-013	613
10-05-000-002	3860
10-05-000-003	1032
10-05-000-004	304
10-05-000-005	486
10-05-000-006	147
10-05-000-007	102
10-05-000-008	316
10-05-000-009	1614
10-05-000-010	1072
10-05-000-011	7672
10-05-000-012	457
10-05-000-013	201

VELVET DRIVE® DISTRIBUTORS



Anthony Keats Marine Ltd.
78 Talbot Street
Wheatley, Ontario, Canada NOP 2P0
Phone: 519/825-4631
Ontario; Quebec

Atlantis Power Inc.
34600 Klein
Fraser, MI 48026
Phone: 313/294-0140
Wisconsin; Illinois; Michigan;
Indiana; Ohio; Minnesota;
North Dakota; South Dakota;
Nebraska; Kansas; Iowa; Missouri;
Kentucky

Doc Freeman's, Inc.
999 North Northlake Way
Seattle, WA 98103
Phone: 206/633-1500
Washington; Oregon; Idaho; Montana;
Wyoming; Alaska

Hale Marine
6080 Historyland Highway
Warsaw, VA 22572
Phone: 804/333-3677
Maryland; Virginia; West Virginia;
District of Columbia; Delaware;
North Carolina

Industrial Engine, Ltd.
8975 Oak Street
Vancouver B.C. Canada V6P 4B8
Phone: 604/266-4126
Western Canada (British Columbia,
Alberta, Saskatchewan, Manitoba,
Yukon, and Northwest Territory)

M & L Engine Division
M & L Industries, Inc.
1210 St. Charles Street
Houma, LA 70360
Phone: 504/876-2280
Arkansas; Louisiana; Mississippi;
Alabama; Tennessee

Marine Gear Supply, Inc.
P. O. Box 796
RTE 1
Rowley, MA 01969
Phone: 617/948-7901
Maine; New Hampshire; Vermont;
Massachusetts

Marine Transmission Service
2780 Hamilton Blvd.
South Plainfield NJ 07080
Phone: 201/668-0300
New York; Pennsylvania; Connecticut;
New Jersey; Rhode Island

Palmer Power Corporation
6451 Rupley Circle,
Houston, TX 77087
Phone: 713/644-6410
Texas; Oklahoma; New Mexico

Sea-Power Marine
333 Kennedy Street
Oakland CA 94606
Phone: 415/533-9290
California; Arizona; Utah; Nevada;
Colorado; Hawaii

C. E. Smith Company
16872 Milliken Ave.
Irvine, CA 92713
Phone: 714/863-1924
California; Arizona; Utah; Nevada;
Colorado; Hawaii

Steel & Engine Products, Ltd.
P.O. Box 1120
Liverpool, Nova Scotia BOT 1K0
Canada
Phone: 902/354-3483
Eastern Canada; New Brunswick;
Nova Scotia; Newfoundland;
Prince Edward Island

Transmission Marine, Inc.
440 N.W. First Ave.,
Fort Lauderdale, FL 33301
Phone: 305/467-1508
Florida; Georgia; South Carolina