

TO: SERVICE MANAGER TECHNICIANS
PARTS MANAGER

No. 89-8

Hinge Pin Torque Change 120R-MR - 260R-MR and All Alpha Ones

The hinge pin torque has increased from 60 lb. ft. (81 N.m) of torque to 95 lb. ft. (129 N.m) of torque.

Shift Spool Assembly All MCI-120R-MR - 260R-MC and All Alpha Ones

These will no longer be sold as separate components. If the spool assembly would have to be taken apart to clean out foreign material such as metal particles from damaged gears or bearings from water damage, reassemble using the following instructions and drawings.

Assembly of Shift Spool and Actuating Rod

- a. Slide spool onto actuating shaft.
- b. Place first washer, spring and second washer in spool. Apply two drops Type 271 Loctite to threads on retainer. Thread retainer onto spool finger tight. Then tighten securely using a channel lock pliers while holding spool in vise (use caution not to damage the spool by over tightening in vise jaws).
- c. Thread on castle nut (adjusting sleeve) until nut touches washers and a slight resistance is felt.
- d. Loosen castle nut (adjusting sleeve) until next cotter pin slot is aligned with hole in shaft. Spool must spin freely and have no more .002 (.05mm) to .010 (.25mm) end play. Measurement taken between the brass spool and the shoulder at the center shaft, (shown in drawings following).
- e. Install cotter pin between castle nut slots and thru actuating shaft. Spread both ends.

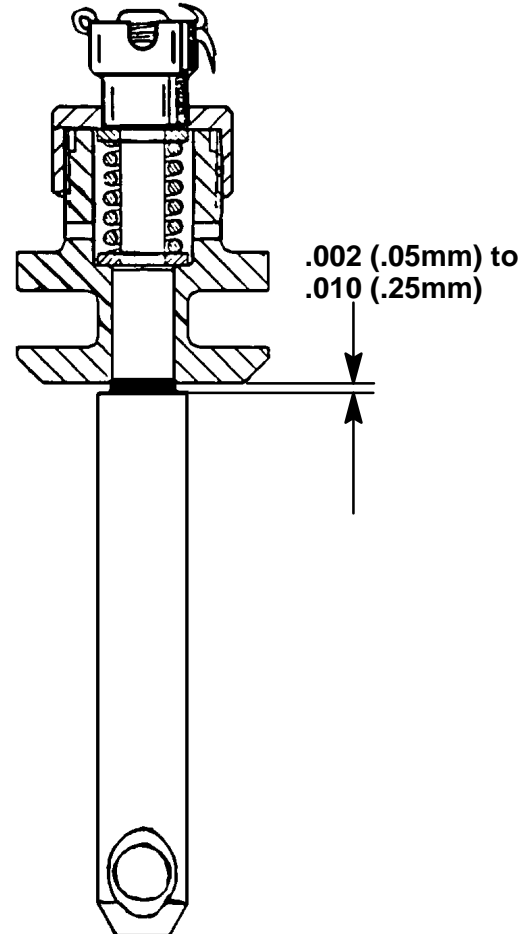

- a - Washers (2)
- b - Spring
- c - Retainer
- d - Spool
- e - Actuating Shaft
- f - Castle Nut
- g - Cotter Pin

Figure 1.