

TO: SERVICE MANAGER TECHNICIANS
PARTS MANAGER

No. 89-1

1988/89 MerCruiser/Sea Ray Engine Identification GM Engine Models

The basic G.M. engine used on a given MerCruiser/Sea Ray model can be determined by looking at the last three digits of the engine code stamped into the cylinder block. (Figure 1) This code number is stamped on all MerCruiser/Sea Ray power packages and replacement partial engines but not replacement cylinder block assemblies.

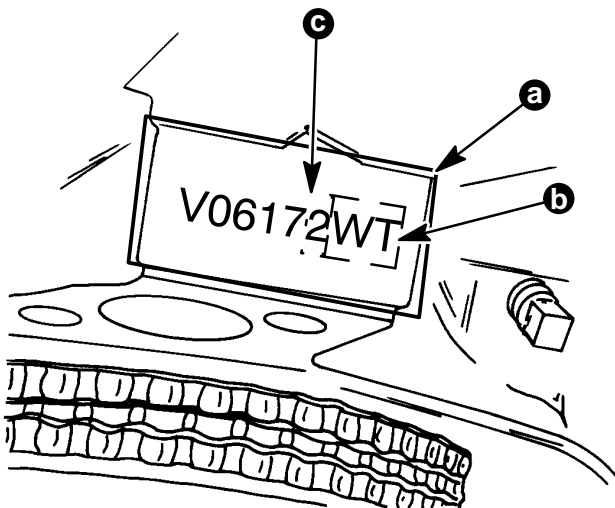

- a - Engine Code (V06172WT)
- b - Last Two Letters (WT)
- c - Last Number (Year-82)

Figure 1. G.M. Engine Code

16425

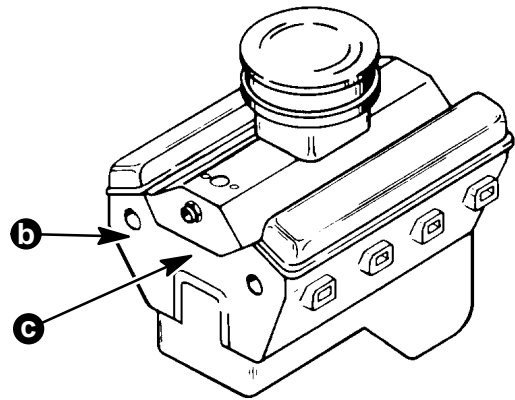
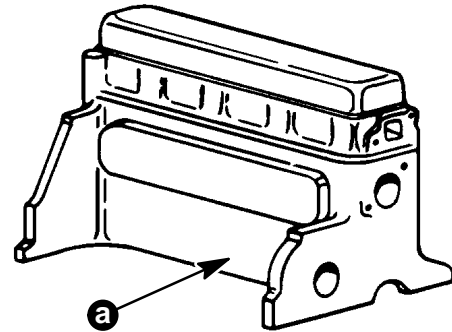

- a - 4 Cylinder-In-Line (Near Distributor)
- b - V-6 and Small Block V-8 (Front, Starboard Side, Near Cylinder Head Mating Surface)
- c - Large Block V-8 (Front of Engine Just Above Timing Gear/Chain Cover)

Figure 2. G.M. Engine Code Location

If the engine serial number, and/or model decals are missing, the engine code may help in determining the engine model. Following is a list of the 1988/89 G.M. engines and their respecting code letters.

MCM Stern Drive Engines

<u>Model</u>	<u>G.M. Code</u>	<u>Rotation</u>		<u>Flywheel In.</u>	<u>Diameter In.</u>
2.5 Litre	NB	L.H.	4 Cyl/153 CID	12-3/4	(324)
3.0 Litre	RS/RA	L.H.	4 Cyl/181 CID	12-3/4	(324)
4.3 Litre	KP	L.H.	V-6/262 CID/Roller Tappet Cam	14	(356)
4.3 Litre LX	KR	L.H.	V-6/262 CID/Roller Tappet Cam	14	(356)
5.0 Litre	PC	L.H.	V-8/305 CID/New Cylinder Heads	14	(356)
5.0 Litre LX	PD	L.H.	V-8/305 CID/New Cylinder Heads	14	(356)
5.7 Litre	AB	L.H.	V-8/350 CID/New Cylinder Heads	14	(356)
5.7 Litre (Bravo Two)	AB	L.H.	V-8/350 CID/New Cylinder Heads Hi Rise Intake Manifold	14	(356)
350 Magnum	AS	L.H.	V-8/350 CID/New Cylinder Heads Hi Rise Intake Manifold	14	(356)
454 Magnum (Alpha One)	XS	L.H.	V-8/454 CID	14	(356)
7.4L Magnum (Alpha One)	XS	L.H.	V-8/454 CID	14	(356)
7.4 Litre	XY	L.H.	V-8/454 CID/2 Bolt Main	14	(356)
7.4 Litre	XW	L.H.	V-8/454 CID/4 Bolt Main	14	(356)
454 Magnum (Bravo One)	XA	L.H.	V-8/454 CID/4 Bolt Main	14	(356)
HP 320 EFI	AK	L.H.	V-8/350 CID/4 Bolt Main/New Heads	14	(356)
HP 420	XF	L.H.	V-8/454 CID/4 Bolt Main	14	(356)
HP 575	No Code	L.H.	V-8/540 CID/GM/Mercury Marine	14	(356)

MIE Inboard Engines

<u>Model</u>	<u>G.M. Code</u>	<u>Rotation</u>		<u>Flywheel In.</u>	<u>Diameter In.</u>
5.0 Litre	PF	L.H.	V-8/305 CID/New Cylinder Heads	14	(356)
5.0 Litre	PH	R.H.	V-8/305 CID/New Cylinder Heads	14	(356)
5.7 Litre	AN	L.H.	V-8/350 CID/New Cylinder Heads	14	(356)
5.7 Litre	AR	R.H.	V-8/350 CID/New Cylinder Heads	14	(356)
5.7 Ski	AB	L.H.	V-8/350 CID/New Cylinder Heads	14	(356)
5.7 Ski	AR	R.H.	V-8/350 CID/New Cylinder Heads	14	(356)
5.7 Ski	AR	R.H.	V-8/350 CID/New Cylinder Heads	14	(356)
7.4 Litre	XY	L.H.	V-8/454 CID	14	(356)
7.4 Litre	XZ	R.H.	V-8/454 CID	14	(356)

Sea Ray Engines

<u>Model</u>	<u>G.M. Code</u>	<u>Rotation</u>		<u>Flywheel In.</u>	<u>Diameter In.</u>
3.0L	RS/RA	L.H.	4 Cyl/181 CID	12-3/4	(324)
4.3L2	KP	L.H.	V-6/262 CID/Roller Tappet Cam	14	(356)
4.3L4	KR	L.H.	V-6/262 CID/Roller Tappet Cam	14	(356)
5.7L	AB	L.H.	V-8/350 CID/New Cylinder Heads	14	(356)
5.7SRX	AS	L.H.	V-8/350 CID/New Cylinder Heads Hi Rise Intake Manifold	14	(356)
7.4SRX	XS	L.H.	V-8/454 CID/Alpha Drive	14	(356)
7.4SRB	XW	L.H.	V-8/454 CID/Bravo Drive	14	(356)
7.4SRX-H	XA	L.H.	V-8/454 CID/4 Bolt Main/Bravo Drive	14	(356)