

TO: SERVICE MANAGER  TECHNICIANS   
PARTS MANAGER

No. 89-18

## MCM and MIE 7.4L (454 CID) Cylinder Head Bolts

MerCruiser 7.4L (454 CID) engines have a new type of cylinder head bolt. This bolt has a taller 1/2 in. socket shoulder head, compared to the flat headed 5/8 in. socket headed bolt previously used (Figure 1).

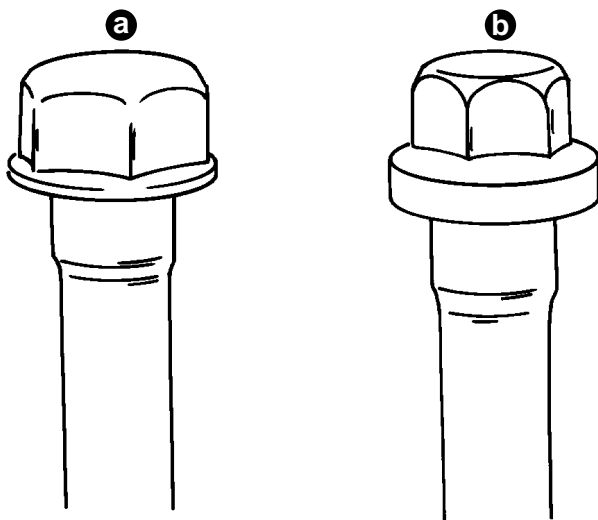

27058

- a - Flat Headed 5/8 in. Bolt
- b - Shoulder Headed 1/2 in. Bolt

**Figure 1.**

Exhaust manifolds are now being cast with added clearance in the bottom to clear the new head bolts. Some 7.4L (454 CID) engines have the new head bolt and old exhaust manifolds (S/N list following). These engines were called back to Stillwater for rework. Starting serial number of engines that have the correct exhaust manifold; MCM/MIE 7.4L (454 CID) OC661242.

All future partial engines with new head bolts must have clearance (daylight) between the top of the head bolts and bottom of exhaust manifold. If manifold makes contact with bolts, the manifold could be replaced (correct manifolds P/N 89011A8 are in parts stock) or rework the old manifolds in the correct area and to specifications shown in Figure 2.

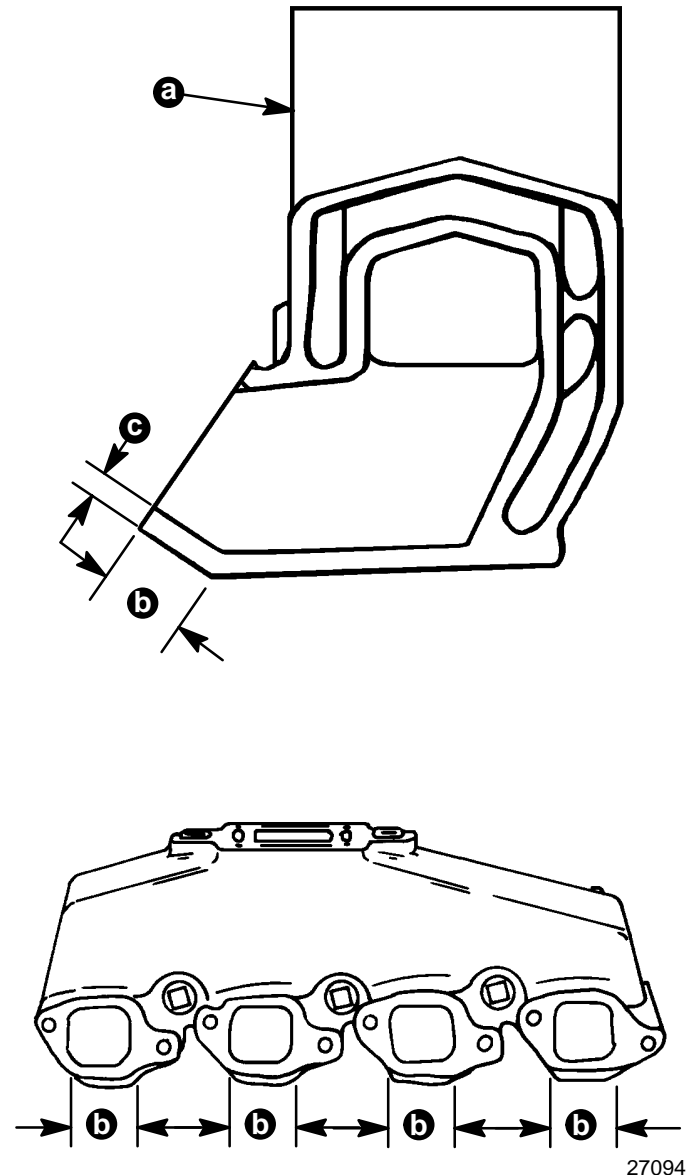

27094

**NOTE:** MerCruiser recommends that a reputable machine shop rework the exhaust manifolds.

- a - Cross Section (End view) of a 7.4L (454 CID) Exhaust Manifold
- b - Areas to be Machined for Clearance. Bottom – outside of each Exhaust Manifold Port
- c - Machine to an Absolute Minimum thickness of .280 – .320 in. (7 – 8mm). Measure thickness of Port “floors” with an accurate micrometer.

**Figure 2.**

**MCM and MIE 7.4L S/N List of Engines with New  
Style Head Bolt and Old Style Exhaust Manifolds**

OC624807	OC657714	OC657743
OC624810	OC657715	OC657744
OC624811	OC657716	OC657745
OC624812	OC657717	OC657746
OC624814	OC657718	OC657747
OC657690	OC657719	OC657748
OC657691	OC657720	OC657749
OC657692	OC657721	OC657750
OC657693	OC657722	OC657751
OC657694	OC657723	OC658160
OC657695	OC657724	OC658161
OC657696	OC657725	OC658162
OC657697	OC657726	OC658163
OC657698	OC657727	OC658165
OC657699	OC657728	OC658166
OC657700	OC657729	OC658168
OC657701	OC657730	OC658170
OC657702	OC657731	OC658171
OC657703	OC657732	OC658174
OC657704	OC657733	OC658178
OC657705	OC657734	OC658182
OC657706	OC657735	OC658187
OC657707	OC657736	OC658192
OC657708	OC657737	OC658197
OC657709	OC657738	OC658199
OC657710	OC657739	OC658205
OC657711	OC657740	OC658220
OC657712	OC657741	
OC657713	OC657742	