

TO: SERVICE MANAGER TECHNICIANS
PARTS MANAGER

No. 90-15

Delco EST Ignition System

Models

MCM 3.0L, 3.0LX

Serial Number: Unknown; production in Stillwater to start in January 1991.

Change

The present Prestolite or DDIS ignition systems used on these engines have been discontinued. All future production of these engines will use the Delco EST ignition system.

Delco EST System

Engine timing **CANNOT** be set the same way the other engines are. There is a special timing procedure that must be followed (see Timing Procedure).

Shop Tachometer Connection

A gray wire, with a female bullet connector coming out of the engine harness (next to the harness gray and purple wires going to the coil), can be used to connect a shop tachometer to the ignition system. The first 50 pre-production engines did not have this connector, so the boat's tachometer will have to be used when servicing the engine.

Special Service Tool

- 1 - Timing Jumper, 91-818812A1
- 1 - Kent-Moore Module Tester, J24642*

*Order directly from Kent-Moore Tool Co.

General Information

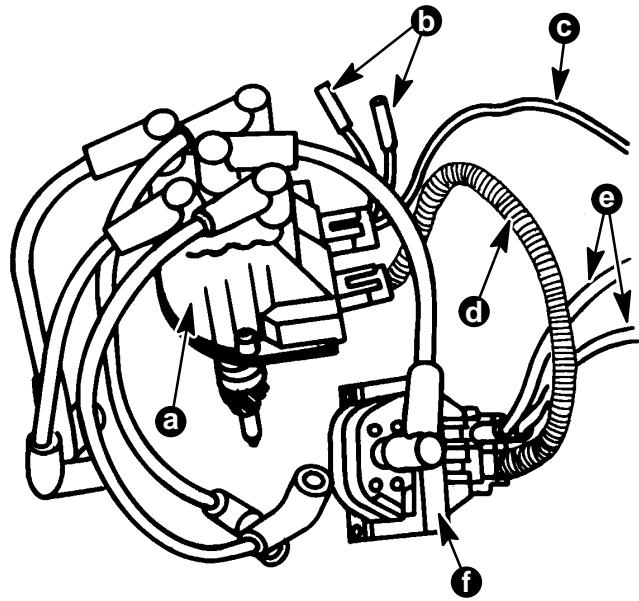

70106

- a - Distributor, with spark plug wires
- b - Wires (white), used in timing procedure
- c - Wire from shift interrupt switch
- d - Distributor harness
- e - Engine harness wires--1 gray and 1 purple
- f - Coil

EST or electronic spark timing is a High Energy Ignition System (HEI). The distributor itself has no centrifugal advance mechanism or devices.

The spark plug wires are a carbon-impregnated cord conductor with a silicone rubber jacket. It is important they be handled with care, and routed so as not to cross each other, or to be in contact with other parts of the engine to prevent rubbing.

The EST System uses a square looking coil with epoxy covered windings to protect against moisture and arc-over.

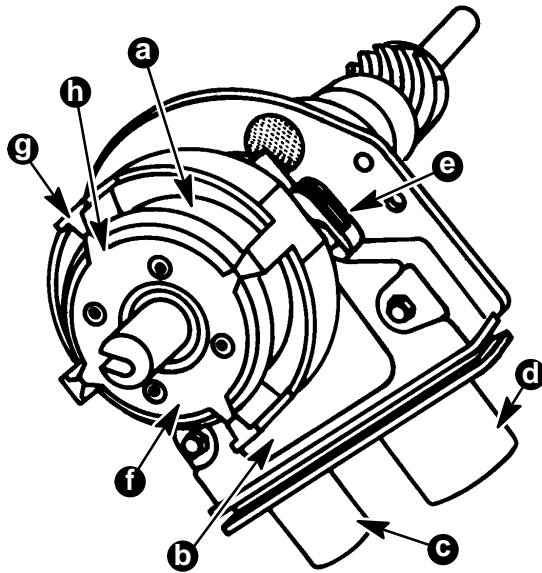

70107

- a - Magnetic Pulse Generator
- b - Electronic Module
- c - Two Prong connector
- d - Four Prong Connector
- e - Pick-up Coil Connector
- f - Timer Core
- g - Pole Piece Teeth
- h - External Teeth

EST utilizes a magnetic pulse generator and an electronic module to control primary circuit current. Internally the Pulse Generator, or magnetic pick-up assembly, takes the place of conventional points. A timer core on the main shaft of the distributor has external teeth which align with an equal number of pole piece teeth (four for a four cylinder engine). The electronic module is small enough to allow it to be mounted inside the distributor, and contains the circuits necessary for dwell control and advance of the timing.

Molded into the module is a two-prong connector for the coil terminals and a four-prong connector. Only three of the four terminals of the second connector are used by MerCruiser. (One for Shift Interrupt and two white leads are used to "freeze" advance for properly setting initial timing.) Inside the distributor, the pick-up coil attaches to the module at a molded prong connector.

Timing Procedure

IMPORTANT: Failure to follow the timing procedure instructions will result in improper timing causing performance problems and possible severe engine damage.

1. Start engine and allow to reach operating temperature.
2. With engine running, install a jumper wire (b) across the two (2) white leads (a) on the distributor using P/N 91-818812A1, or fabricate using a 6 in. (150mm) section of 16 gauge wire with two (2) male bullet terminal ends connected.

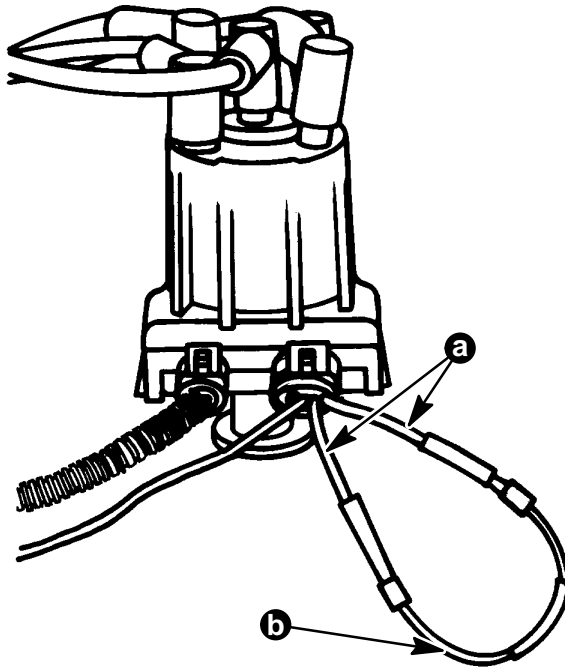

70103

3. Bypass the shift interrupt switch by disconnecting wires at shift interrupt switch and temporarily joining together.

IMPORTANT: Do not fail to reconnect these two wires to the shift interrupt switch when timing procedures are complete.

4. With timing light connected, check timing. Timing should be 1 degree BTDC.
5. If required, loosen distributor hold down clamp and rotate distributor to obtain specified timing.
6. Secure distributor hold down clamp, and recheck timing as above.
7. Reconnect the two wires to the shift interrupt switch. Remove jumper wire at distributor white leads.

IMPORTANT: Be certain to remove jumper wire before returning engine to service, otherwise timing will not advance.

8. With timing light still connected, and engine at IDLE, verify that timing did advance to 12 degrees BTDC, plus or minus 2 degrees. At 2400-2800 RPM maximum (total) advance is obtained and should be 27 degrees BTDC, plus or minus 2 degrees.
9. Remove timing light.

Testing Ignition Components

The following tests can be made with the distributor and coil mounted on or off the engine. The test procedures will check each component of the distributor and ignition coil. Distributor cap and rotor should be checked for corrosion, cracks, carbon tracks or wear. Replace if needed.

In order to test the module, an approved module tester, such as a Kent-Moore Module Tester, P/N J24642 or equivalent, must be used. Be certain to follow the manufacturer's directions precisely for proper results. However, do not overlook that corrosion on the terminals of the module could cause improper ignition action and should therefore be inspected and cleaned if needed.

Testing Pickup Coil

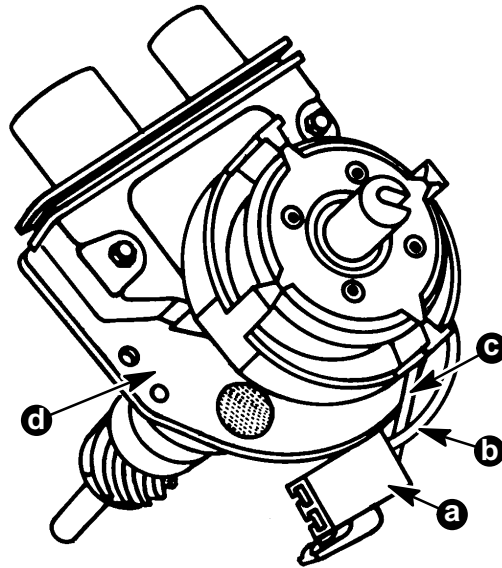

70105

1. Remove distributor cap.
2. Identify the two pickup coil leads. On almost all applications these two leads are one white (c) and one green (b). Remove the connector (a) that houses these two leads from the module.
3. Set ohmmeter to "Rx10" scale. Connect one lead of ohmmeter to white lead (c) and the other lead to distributor housing (d). Reading should be infinite. If not, replace pickup coil.
4. Repeat Step 3 with ohmmeter connected to green lead. Reading should be infinite. If not, replace pickup coil.
5. Set ohmmeter to "Rx100" scale. Connect ohmmeter to green (b) and white (c) pickup coil leads. Reading should be a constant, unchanging value in the range of 500-1500 ohms. If not, replace pickup coil. Be certain to flex leads by hand during this test to locate possible intermittent "open" circuits (loss of continuity. If any exist, replace pickup coil.

Testing Ignition Coil

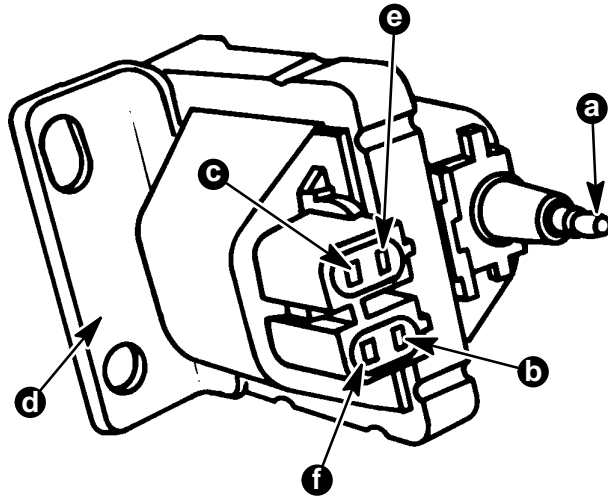

70104

1. If not already done, disconnect wiring from ignition coil. Connectors are molded and keyed to assure proper positioning. [NOTE: upon reinstallation, first install black connector (distributor harness) to coil. Then install gray connector (engine harness).] The terminal (e) feeds 12 volts to the distributor.
2. Set ohmmeter to "Rx100" scale and connect one lead to 12 volt terminal (b) of coil and the other lead to "ground" (d), any clean metal area on the coil frame. Reading should be infinite. If not, replace coil.
3. Set ohmmeter to "Rx1" scale and connect to 12 volt terminal (b) and terminal (c). Reading should be approximately .4 ohms. If not, replace coil.
4. Set ohmmeter to "Rx1" scale and connect to 12 volt terminal (b) and tachometer terminal (f). Reading should be approximately .4 ohms. If not, replace coil.
5. Set ohmmeter to "Rx100" high scale. Connect ohmmeter to 12 volt terminal (b) and to coil high tension post (a). Reading should be between 7800 and 8800 ohms. If it reads outside of this range, replace coil.