

TO: SERVICE MANAGER MECHANICS
PARTS MANAGER

No. 91-16

MCM 454 Magnum Bravo GM Generation V Engine Specifications

NOTE: Generation V Engines Have the Fuel Pump Mounted on the Belt Driven Seawater Pump.

- A. Tune-up Specifications
- B. Electrical Specifications
- C. Carburetor Specifications
- D. Internal Engine Specifications
- E. Torque Specifications
- F. Wiring Diagram (Engine)
- G. Water Flow Diagram

A. TUNE-UP SPECIFICATIONS

Model	454 Magnum Bravo
Propshaft Horsepower (Kilowatts)	350 (262)
Displacement	454 CID (7.4L)
Engine Type and Number of Cylinders	V8
Bore	4.25 in. (108mm)
Stroke	4.00 in. (101.6mm)
Compression Ratio	8.6:1
Compression Pressure	150 psi (1035 kPa)
Ignition	Thunderbolt IV HEI
Spark Plug Type	AC-MR43T or Champion RV8C
Spark Plug Gap	.035 in. (0.9mm)
Timing at Idle RPM	8° BTDC
Maximum RPM at Wide-Open-Throttle	4600-5000
Idle RPM in Forward Gear	650-700
Firing Order	1-8-4-3-6-5-7-2
Fuel Required	87 Octane Minimum (Average Octane Rating)
Fuel Pump Pressure	3-7 psi (21-48 kPa)

Model	454 Magnum Bravo
Electrical System	12V Negative (-) Ground
Alternator Rating	55 Amps
Minimum Battery Rating Required	450 CCA or 90 Ah
Crankcase Oil Capacity with New Filter*	Approx. 7 U.S. Qts. (6.6L)
Oil Pressure at 2000 RPM	30-70 psi (207-483 kPa)
Minimum Oil Pressure @ Idle	4 psi (28 kPa)
Valve Lash	Not Adjustable
Thermostat	143° F (62° C)
Cooling System Capacity	20 U.S. Qts. (19.3L)
Closed Cooling System Capacity	28 U.S. Qts. (26.5 L)
*Stern Drive Unit Oil Capacity (Approx.)	Bravo One-2.8 U.S. Qts.(2.6L)

*Approximately, ALWAYS use dipstick to determine exact quantity of oil required.

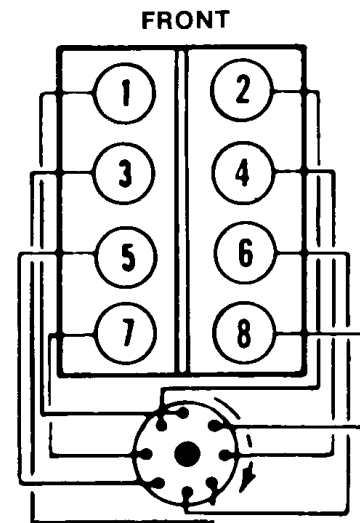

Firing Order
1-8-4-3-6-5-7-2

Figure 1. L.H. Rotation

B. ELECTRICAL SPECIFICATIONS

Coil Specifications

Coil	Part No. 392-7803A4
Coil Primary Resistance (Ohms) Minimum	.60
Coil Primary Resistance (Ohms) Maximum	.80
Coil Secondary Resistance (Ohms)	9.400-11.700

Starter Motor Specifications

Part Number (Delco-Remy Number)	No Load Test					Brush Spring Tension
	Volts	Min. Amps	Max. Amps	Min. RPM	Max. RPM	
50-812428A_ (9000762) 50-812604A_ (9000768)	10.6	60	90	3,000	3,300	83-104 oz. (2353-2948 g)

IGNITION MODULE SPECIFICATIONS

Part Number: 15248A1
 Identification Mark: V8-24
 Module Advance: 24°
 Initial Timing: 8° BTDC
 Total Advance: 32°

Advance Curve

IMPORTANT: Advance curve chart does not include initial timing. Initial engine timing must be added to curve for total advance curve.

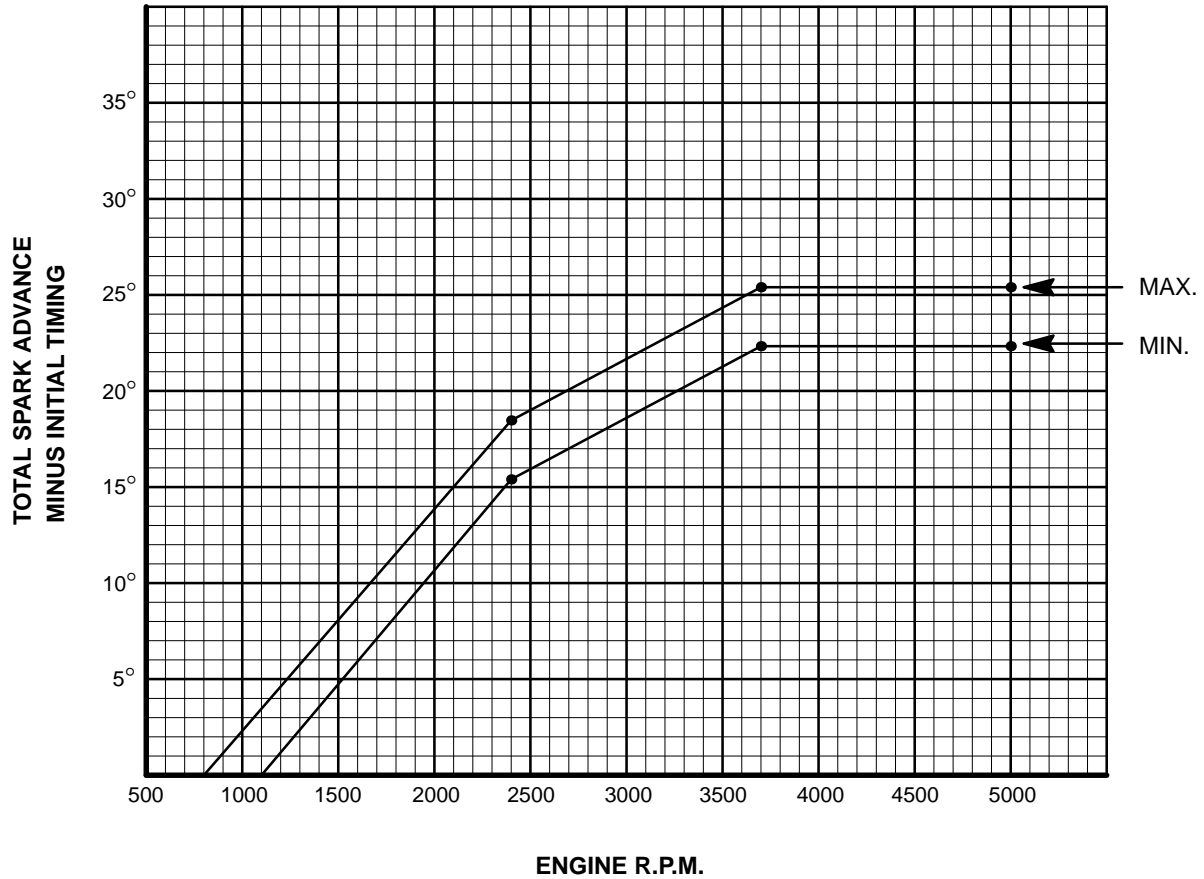

C. CARBURETOR SPECIFICATIONS

All measurements are $\pm 1/64$ in. (0.4mm).

Model 454 Magnum Bravo

Part Number (Weber)	3310-816917A2 (9773)
Float Drop	2 in. (51mm)
Float Level	1-9/32 in. (33mm)
Pump Rod Hole Location	#3 from End
Accelerator Pump	7/16 in. (11mm) NOTE:1
Choke Pull Off	1/8 in. (3.3mm)
Choke Coil Rod	Top of Rod to be Even with Bottom of Lever Hole (NOTE:2)
Primary Jet	.107 in.
Metering Rod (Number)	16-6542
Secondary Jet	.107 in.
Idle Mixture Screw (Preliminary)	2 Turns

NOTE 1: Measured from Top of Carburetor to the bottom of "S" link.

NOTE: 2 Remove choke rod from lever hole. Choke held closed and choke rod pushed down next to lever.

D. INTERNAL ENGINE SPECIFICATIONS

**UNIT OF MEASUREMENT
in. (mm)**

Cylinder Bore:

Model		454 Magnum Bravo	
Diameter		4.2451-4.2525 (107.826-108.013)	
Out of Round	Production	.001 (0.0254) Max.	
	Service	.002 (0.05) Max.	
Taper	Production	Thrust Side	.0005 (0.0127) Max.
		Relief Side	.001 (0.0254) Max.
	Service	.001 (0.02)Max.	

Piston:

Clearance	Production	.0025-.0037 (0.0635-0.0939)
	Service	.0075 (0.15) Max.

Piston Ring: (1)HI Production Limit

Compression	Groove Side Clearance	Production	Top	.0017-.0032 (0.0432-0.0812)
			2nd	.0017-.0032 (0.0432-0.0812)
		Service	(1) + .001 (0.02)	
Gap		Production	Top	.010-.018 (0.2540-0.4572)
			2nd	.016-.024 (0.4064-0.6096)
		Service	(1) + .010 (0.25)	
Oil	Groove Side Clearance	Production	.0050-.0065 (0.1270-0.1651)	
		Service	(1) + .001 (0.02)	
	Gap	Production	.020-.035 (0.508-0.889)	
Service		(1) + .010 (0.25)		

Piston Pin:

Diameter	.9895-.9898 (25.1333-25.1409)	
Clearance	Production	.00025-.00035 (0.0064-0.0088)
	Service	.001 (0.02) Max.
Fit in Rod	.0008-.0016 (0.0203-0.0406) Interference	

Crankshaft:

Main Journal	Diameter	No. 1,2, 3, 4, 5	2.7482-2.7489 (69.8042-69.8220)
	Taper	Production	.0002 (0.0051) Max.
		Service	.001 (0.02) Max.
Out of Round	Production		.0002 (0.0051) Max.
	Service		.001 (0.02) Max.
Main Bearing Clearance	Production	No. 1,2, 3, 4,	.0017-.0030 (0.0431-0.0762)
		No. 5	.0025-.0038 (0.0635-0.0965)
	Service	No. 1, 2, 3, 4	.001-.003 (0.03-0.07)
		No. 5	.0025-.0040 (0.07-0.10)
Crankshaft End Play			.006-.010 (0.15-0.25)
Connecting Rod Journal	Diameter		2.1990-2.1996 (55.8546-55.8698)
	Taper	Production	.0005 (0.0127) Max.
		Service	.001 (0.02) Max.
	Out of Round	Production	
Service			.001 (0.02) Max.
Rod Bearing Clearance	Production		.0011-.0029 (0.0279-0.0736)
	Service		.003 (0.07) Max.
Rod Side Clearance			.002-.023 (0.05-0.58)
Crankshaft Runout			.0015 (0.038) Max.

Camshaft and Drive:

		Model	454 Magnum Bravo
Lobe Lift ± .002 (0.051)	Intake	Exhaust	.300 (7.62)
		Exhaust	.300 (7.62)
Duration @ .050 in. (1.27mm) Cam Lift	Intake		224°
	Exhaust		224°
Journal Diameter			1.9482-1.9492 (49.4842-49.5096)
Journal Out-of-Round			.001 (0.025) Max.
Camshaft Run-Out			.002 (0.051) Max.
Timing Chain Deflection			3/8 (10mm) from Taut Position 3/4 (19mm) Total

Valve System:

Lifter Type		Hydraulic	
Rocker Arm Ratio		1.7:1	
Valve Lift	Intake	.510 (12.954)	
	Exhaust	.510 (12.954)	
Valve Lash (Intake & Exhaust)		Fixed Lash	
Face Angle (Intake & Exhaust)		45°	
Seat Angle (Intake & Exhaust)		46°	
Seat Runout (Intake & Exhaust)		.002 (0.05) Max.	
Seat Width	Intake	1/32-1/16 (0.8-1.6)	
	Exhaust	1/16-3/32 (1.6-2.3)	
Stem Clearance	Production	Intake	.0010-.0027 (0.0254-0.0685)
		Exhaust	.0012-.0029 (0.0304-0.0736)
	Service	Intake	.003 (0.09)
		Exhaust	.004 (0.012)

Model		454 Magnum Bravo	
Valve Spring	Free Length	2.15 [2-5/32] (54.61)	
	Pressure (NOTE 1)	Closed @ 1.88 [1-7/8] (47.8)	110 lbs. ft. (149 N·m)
		Open @ 1.34 [1-3/8] (35.1)	316 lbs. ft. (428 N·m)
	Installed Height	1.88 [1-57/64] (47.75)	
Damper	Free Length Approximate No. of Coils	1.86 [1-55/64] (47.2)	
		4	

NOTE 1: Test spring pressure with inner & outer spring assembled.

Cylinder Head:

Gasket Surface Flatness	.003 (0.07) in 6 (152) - .007 (0.15) Overall Maximum
-------------------------	--

Flywheel:

Runout	.009 (0.22) Max.
--------	------------------

E. TORQUE SPECIFICATIONS

Camshaft Sprocket	25 lb.ft. (34 N·m)
Conn. Rod Cap	73 lb. ft. (99 N·m)
Coupler or Drive Plate	35 lb. ft. (48 N·m)
Cylinder Head	85 lb. ft. (115 N·m)
Distributor Clamp	20 lb. ft. (27 N·m)
Exhaust Manifold (Bolts)	35 lb. ft. (48 N·m)
Flywheel	70 lb. ft. (95 N·m)
Flywheel Housing	30 lb. ft. (41 N·m)
Front Cover	120 lb. in. (14 N·m)
Intake Manifold	35 lb. ft. (48 N·m)
Main Bearing Cap	110 lb. ft. (149 N·m)
Oil Filter Adaptor Nut	40 lb. ft. (54 N·m)
Oil Pan to Crankcase	200 lb. in. (23 N·m)
Oil Pan Drain Plug	20 lb. ft. (27 N·m)
Oil Pump	70 lb. ft. (95 N·m)
Oil Pump Cover	80 lb. in. (9 N·m)
Rocker Arm Bolts	45 lb. ft (61 N·m)
Rocker Arm Cover	70 lb. in. (8 N·m)
Spark Plug	22 lb. ft. (30 N·m)
Torsional Damper	90 lb. ft. (122 N·m)
Water Pump	35 lb. ft. (48 N·m)

F. ENGINE WIRING DIAGRAM (454 MAGNUM BRAVO)

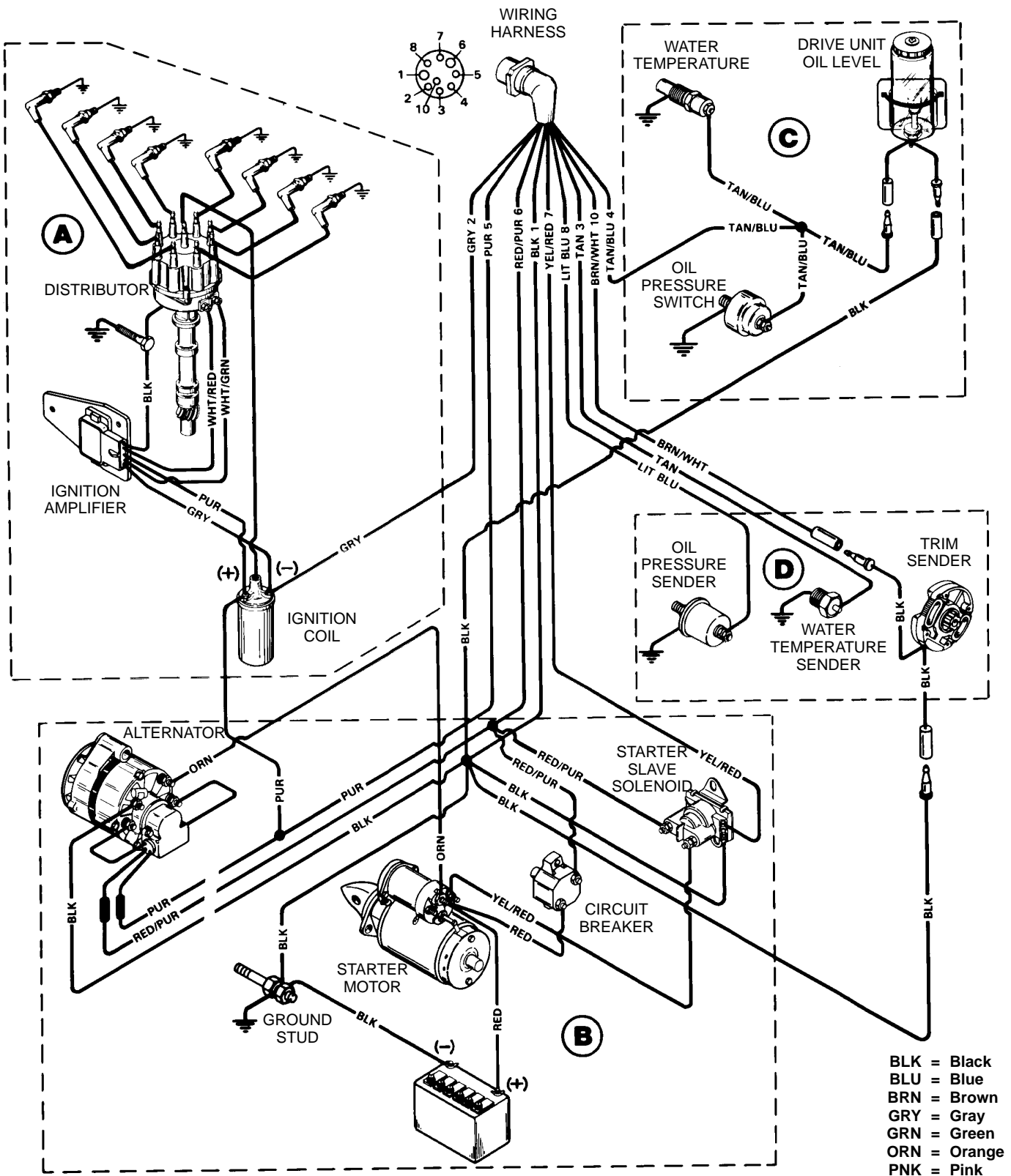

A: Ignition System
B: Starting and Charging System

C: Audio Warning System
D: Instrumentation System

- BLK = Black
- BLU = Blue
- BRN = Brown
- GRY = Gray
- GRN = Green
- ORN = Orange
- PNK = Pink
- PUR = Purple
- RED = Red
- Tan = Tan
- WHT = White
- YEL = Yellow
- LIT = Light
- DRK = Dark

**G. WATER FLOW DIAGRAM (454 MAGNUM BRAVO)
SEAWATER COOLED**

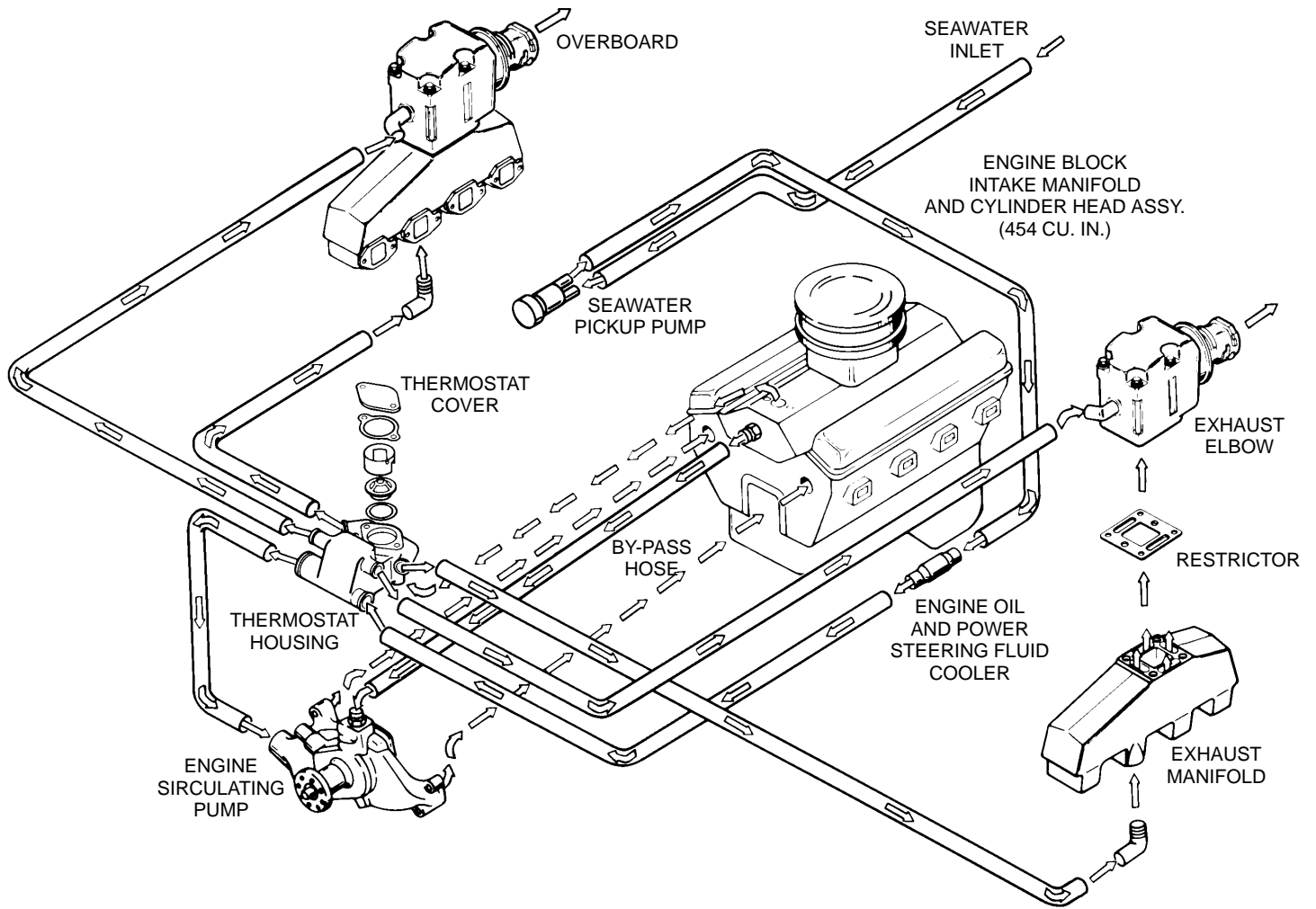

22383

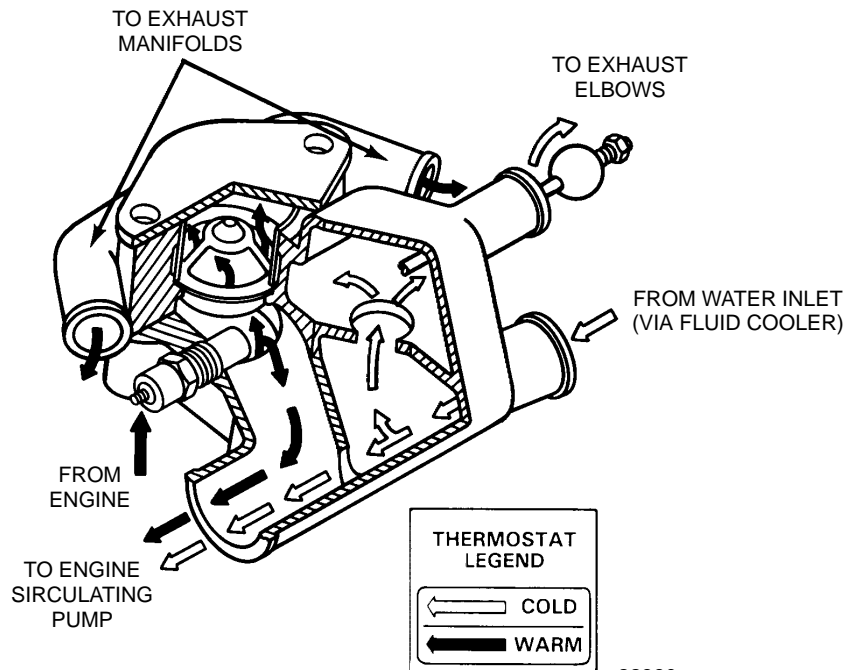

22380