

TO: SERVICE MANAGER TECHNICIANS
PARTS MANAGER

No. 98-16

NOTICE

Revised January, 1999. This bulletin supersedes all of the following bulletins 94-1, 94-16, 96-1 and 97-7.

Bravo Drive Shaft Housing Replacement

Bravo Drive Shaft Housings Affected

1589-8868A25 or 1589-8868A55

Description

The 1589-8868A25 and 1589-8868A55 drive shaft housings will supersede to the 1589-8868G21 drive shaft housing. The anchor pin hole changes from the round aft anchor pin hole to the elongated (slotted) aft anchor pin hole. The elongated (slotted) aft anchor pin hole requires the use of a crescent shaped insert (808006). This insert is included with the housing to position the pin placement for Bravo One / Two / Three.

Bravo One and Two

For the Bravo One and Two, the insert is placed in the **FORWARD most position** in the aft anchor pin hole. This placement will give the normal minus 5 degrees of trim under. The insert may be placed in the **AFT most position** of the slotted hole to limit the amount of trim under for boat hulls requiring less trim under.

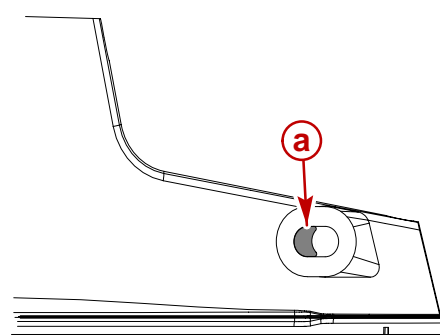

75157

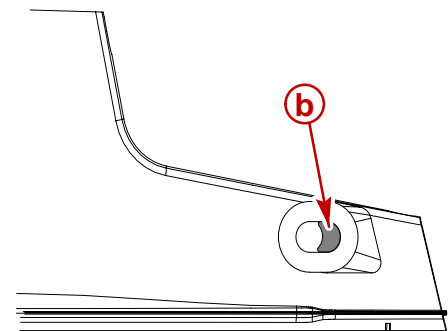

75158

- a** - Bravo One / Two Standard Insert Location
- b** - Bravo One / Two Optional Insert Location

Bravo Three

For the Bravo Three drive unit, the insert **MUST BE** placed in the **AFT most position** in the slotted hole to limit the Trim Under.

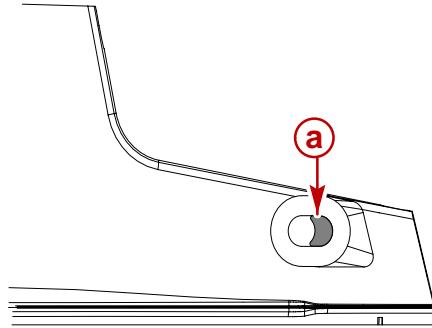

75158

a - Trim-In Limit Spacer Location

When the 1589-8868G21 housing is used on a Bravo Three drive unit, the Trim-In Limit Blocks (806692A2) will no longer be required. **DO NOT** reinstall them on the drive unit. If the blocks are already installed, they **MUST BE REMOVED**.

After placing the insert in the AFT most position of the slotted hole, install a Tilt Limit Spacer Kit (15768A3). Use 1 spacer per cylinder as shown below to prevent the bell housing and drive shaft housing from contacting the gimbal ring U-Bolt.

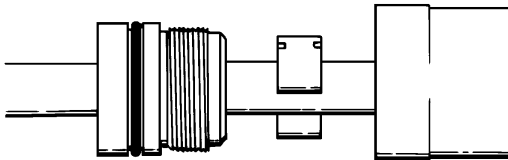

71679

Port Trim Cylinder

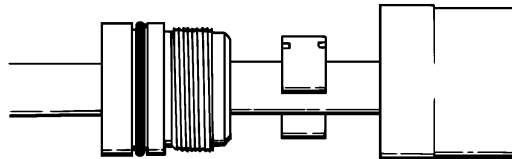

71679

Starboard Trim Cylinder