

Circulate to: Sales Manager Accounting Service Manager Technician Parts Manager

New Heavy Duty Impeller and Inner Wear Plate Kits

NOTICE
Revised November 2016. This bulletin supersedes the previous bulletin number 2016-09 September 2016.

Models Affected

Models Covered	Serial Number
All MerCruiser Gasoline Engines with Brass Seawater Pumps	All

Scope

Worldwide

Situation

Mercury MerCruiser has observed that the front of the seawater pump impeller housing is susceptible to wear if debris is present in the water. If the surface wear is severe, the seawater pump may not prime or provide sufficient water flow.

Mercury MerCruiser now offers 0.030 in. shorter heavy duty impellers and overmolded inner wear plate kits. New service parts including seawater pump assemblies and impeller kits will come with the new heavy duty impeller and overmolded inner wear plate.

Mercury MerCruiser will continue to offer the standard length impeller kits without the inner overmolded wear plate for use in most operating environments where debris is not present in the water.

IMPORTANT: The shorter heavy duty impeller must be used with an overmolded inner wear plate. Do not use a standard impeller with an overmolded inner wear plate.

IMPORTANT: A shorter heavy duty impeller can be identified by its red hub.

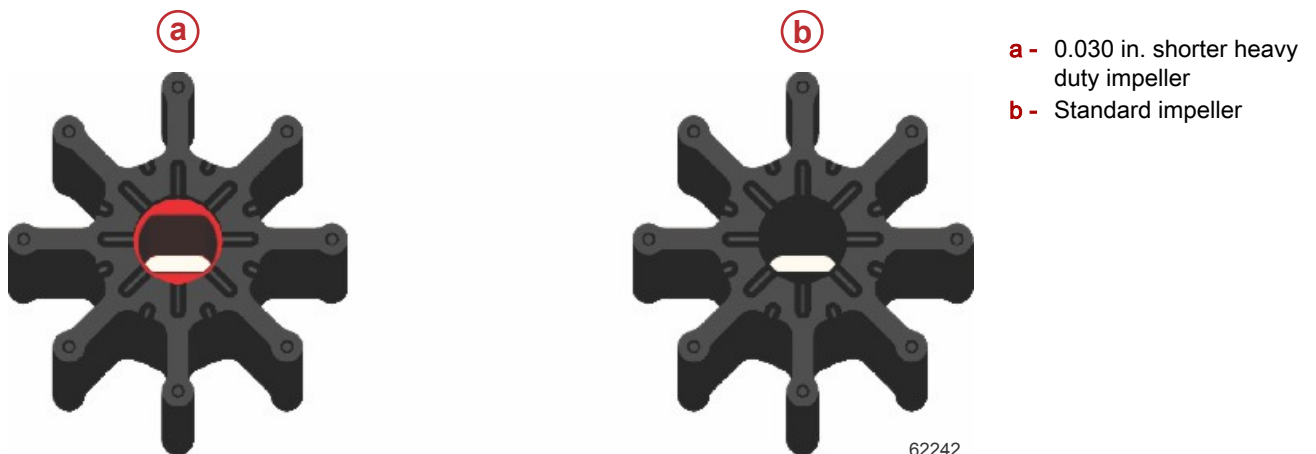

THE INFORMATION IN THIS DOCUMENT IS CONFIDENTIAL AND PROTECTED BY COPYRIGHT AND IS THE PROPERTY OF MERCURY MARINE.

This document is provided for the sole and exclusive use of the original recipient as prescribed by Mercury Marine and may not be distributed or copied, digitally or otherwise, without the prior written consent of Mercury Marine.

Correction

Install a shorter heavy duty impeller and overmolded inner wear plate in seawater pumps that are exposed to environments where excessive sand, silt, or debris may be present.

Kit Part Numbers

Model	Serial Number	Part Number
8.2L Models	All	8M0120891
<i>NOTE: 2A531218—start of production, seawater pump equipped with heavy duty impeller and inner wear plate.</i>		
Gasoline engines with brass seawater pumps excluding Mercury 4.5L and 6.2L Models		

Mercury 4.5L and 6.2L Models

Model	Seawater Pump	Serial Number	Part Number
Mercury 4.5L Bravo MPI	Design 1	2A531162 and below	8M0121939
Mercury 6.2L Bravo MPI	Design 1	2A531196 and below	8M0121939
Mercury 6.2 Inboard MPI	Design 1	2A530773 and below	8M0121939
Mercury 6.2 TowSport MPI	Design 1	2A531347 and below	8M0121939
Mercury 4.5L Bravo MPI	Design 2	2A531163 and above	8M0121940
Mercury 6.2L Bravo MPI	Design 2	2A531197 and above	8M0121940
Mercury 6.2 Inboard MPI	Design 2	2A530774 and above	8M0121940
Mercury 6.2 TowSport MPI	Design 2	2A531348 and above	8M0121940

Heavy Duty Impeller and Inner Wear Plate Kit Installation

IMPORTANT: Always refer to the appropriate Mercury Marine service manual for component removal, disassembly, assembly, and installation instructions.

Gasoline Engines with Brass Seawater Pumps Excluding Mercury 4.5L and 6.2L Models

IMPORTANT: The overmolded inner wear plate must be used with the 0.030 in. shorter heavy duty impeller. The 0.030 in. shorter heavy duty impeller can be identified by its red impeller hub. Do not use a 0.030 in. shorter heavy duty impeller without an overmolded inner wear plate.

IMPORTANT: The bare metal surface of the overmolded inner wear plate must face the 0.030 in. shorter heavy duty impeller.

THE INFORMATION IN THIS DOCUMENT IS CONFIDENTIAL AND PROTECTED BY COPYRIGHT AND IS THE PROPERTY OF MERCURY MARINE.

This document is provided for the sole and exclusive use of the original recipient as prescribed by Mercury Marine and may not be distributed or copied, digitally or otherwise, without the prior written consent of Mercury Marine.

1. Install the overmolded inner wear plate into the impeller housing with the rubber material side of the plate facing down and seated on the floor of the impeller housing.

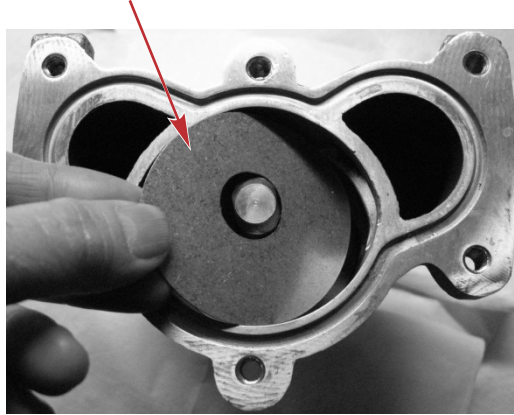

62324

Overmolded inner wear plate (with bare metal surface facing the impeller)

2. Lubricate the 0.030 in. shorter heavy duty impeller with soapy water. Align the flat surfaces of the impeller hub and bearing shaft and install the impeller into the impeller housing.

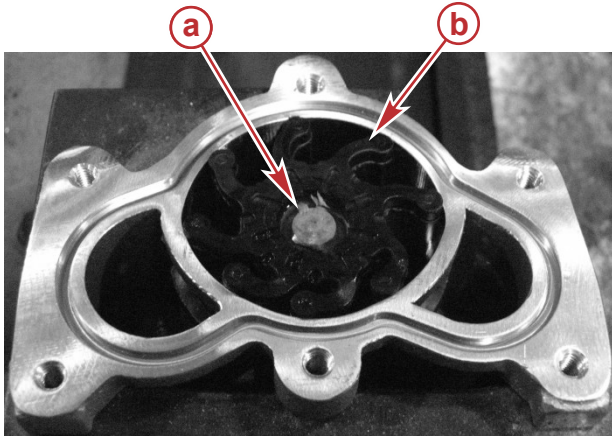

46189

- a** - Red impeller hub
- b** - 0.030 in. shorter heavy duty impeller

3. Install the O-ring into the groove in the rear face of the impeller housing.

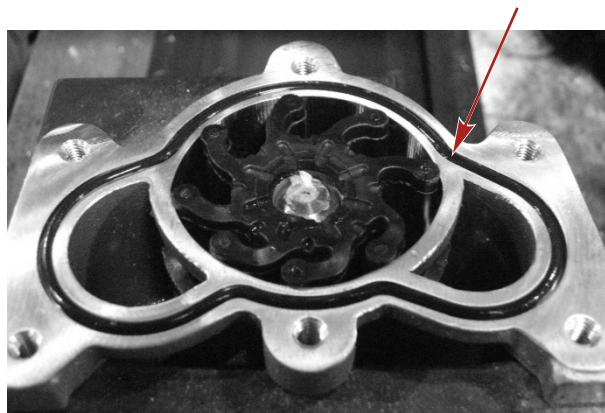

46190

THE INFORMATION IN THIS DOCUMENT IS CONFIDENTIAL AND PROTECTED BY COPYRIGHT AND IS THE PROPERTY OF MERCURY MARINE.

This document is provided for the sole and exclusive use of the original recipient as prescribed by Mercury Marine and may not be distributed or copied, digitally or otherwise, without the prior written consent of Mercury Marine.

- If you have the design shown below, apply a 3.175 mm (0.125 in.) wide bead of adhesive across the actuator housing; then place the stainless steel wear plate on the housing with the tabs aligned. Bolt the assembly to the pump within five minutes.

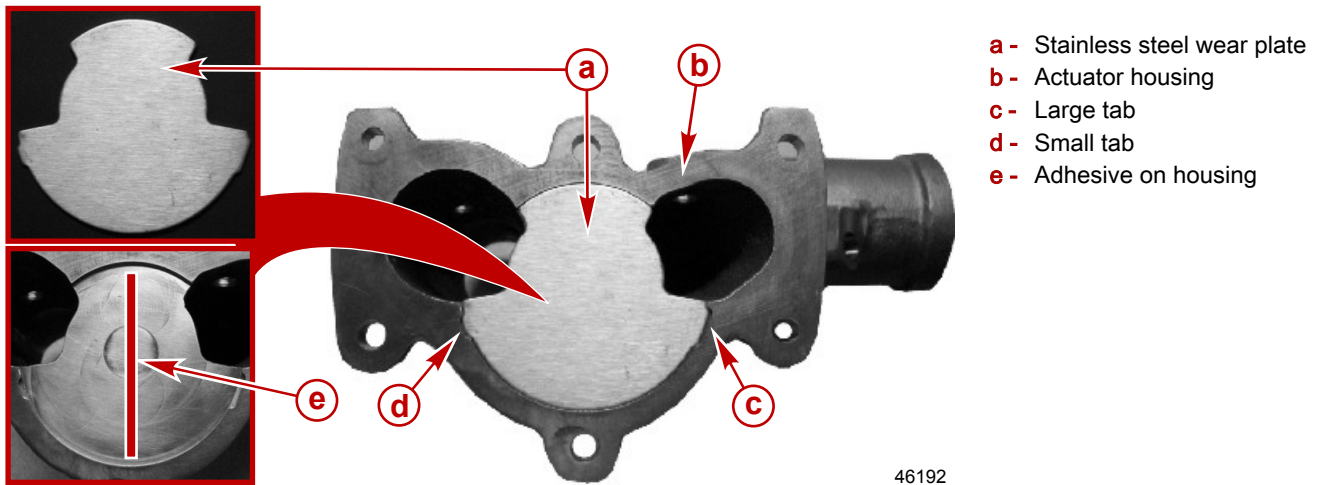

Tube Ref No.	Description	Where Used	Part No.
142	Loctite 598 RTV Sealant	Actuator housing steel wear plate	Obtain Locally

IMPORTANT: The following actuator housing styles will mate with either standard or 0.030 in. heavy duty impeller styles.



- a - Actuator housing style with milled even surface
- b - Actuator housing style with steel wear plate

- Align and install the actuator housing on the impeller housing assembly.
- Screws that are reused may require threadlocker. Apply Loctite 242 Threadlocker to the threads of the screws as necessary.

Tube Ref No.	Description	Where Used	Part No.
66	Loctite 242 Threadlocker	Impeller housing cover or seawater pump actuator housing screw threads	92-809821

THE INFORMATION IN THIS DOCUMENT IS CONFIDENTIAL AND PROTECTED BY COPYRIGHT AND IS THE PROPERTY OF MERCURY MARINE.

This document is provided for the sole and exclusive use of the original recipient as prescribed by Mercury Marine and may not be distributed or copied, digitally or otherwise, without the prior written consent of Mercury Marine.

7. Install the four screws and tighten to the specified torque.

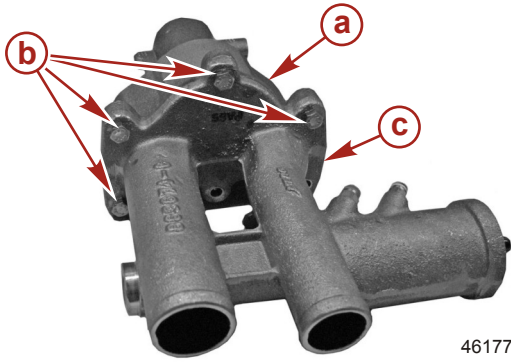

- Seawater pump assembly**
a - Impeller housing
b - Screws
c - Actuator housing

Description	Nm	lb-in.	lb-ft
Impeller housing cover or the seawater pump actuator housing screw	10	88.5	-

Mercury 4.5L and 6.2L Brass Seawater Pump Design Change

Design 1

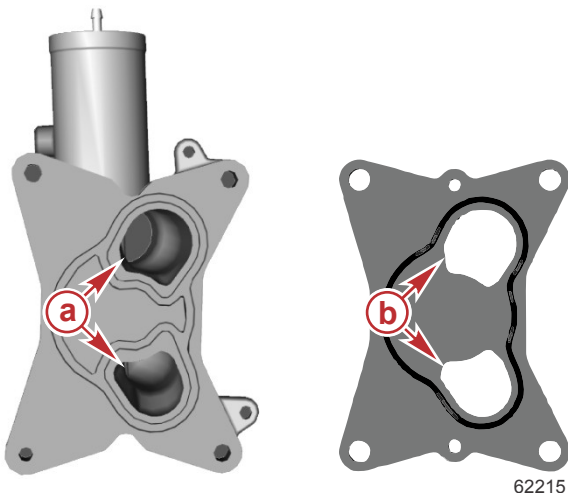

- a** - Drain valve housing
b - Outer wear plate with integrated seal

Design 2

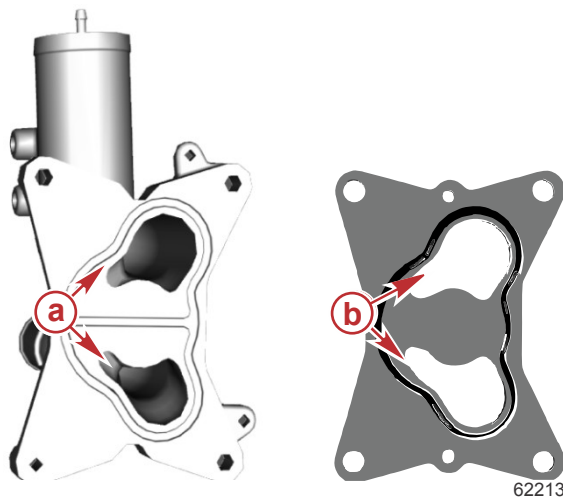

- a** - Drain valve housing with improved porting
b - Outer wear plate with integrated seal and improved porting

THE INFORMATION IN THIS DOCUMENT IS CONFIDENTIAL AND PROTECTED BY COPYRIGHT AND IS THE PROPERTY OF MERCURY MARINE.

This document is provided for the sole and exclusive use of the original recipient as prescribed by Mercury Marine and may not be distributed or copied, digitally or otherwise, without the prior written consent of Mercury Marine.

Mercury 4.5L and 6.2L Brass Seawater Pump Impeller Installation

IMPORTANT: The overmolded inner wear plate must be used with the 0.030 in. shorter heavy duty impeller. The 0.030 in. shorter heavy duty impeller can be identified by its red impeller hub. Do not use a 0.030 in. shorter heavy duty impeller without an overmolded inner wear plate.

IMPORTANT: The bare metal surface of the overmolded inner wear plate must face the 0.030 in. shorter heavy duty impeller.

1. Install the overmolded inner wear plate into the impeller housing with the rubber material side of the plate facing down and seated on the floor of the impeller housing.

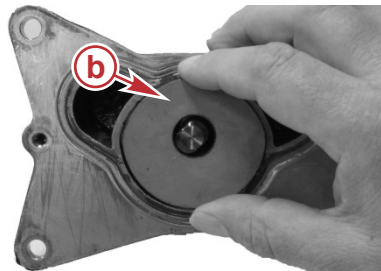
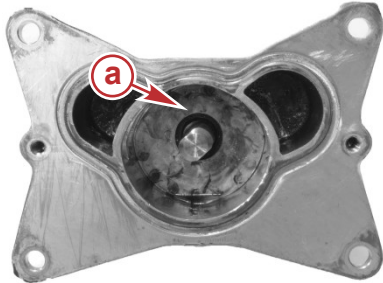

- a - Impeller housing
- b - Overmolded inner wear plate

62023

2. Install the impeller onto the bearing shaft.
3. Align and attach the outer wear plate with integrated seal to the impeller housing with two hex head cap screws. Tighten the screws to the specified torque.

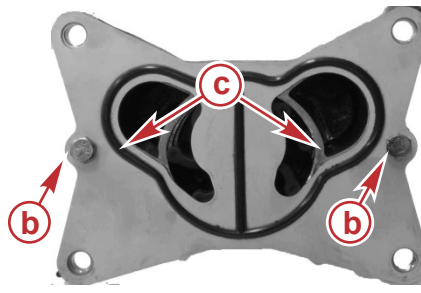
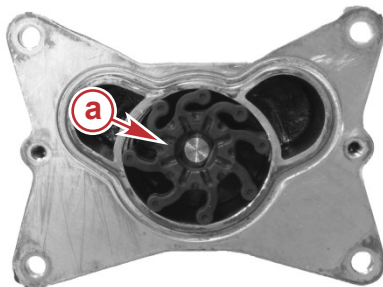

- a - 0.030 in. shorter heavy duty impeller
- b - Outer wear plate screws (2)
- c - Outer wear plate with integrated seals

62474

Description	Nm	lb-in.	lb-ft
Hex head cap screw	10	88.5	-

4. Install the blue drain plugs in the impeller housing, if removed.
5. Align and install the impeller housing assembly onto the seawater pump cover.
6. Apply Loctite 242 Threadlocker to the threads of the seawater pump cover screws.

Tube Ref No.	Description	Where Used	Part No.
66	Loctite 242 Threadlocker	Seawater pump cover screw threads	92-809821

7. Install the four seawater pump cover screws and tighten them to the specified torque.

THE INFORMATION IN THIS DOCUMENT IS CONFIDENTIAL AND PROTECTED BY COPYRIGHT AND IS THE PROPERTY OF MERCURY MARINE.

This document is provided for the sole and exclusive use of the original recipient as prescribed by Mercury Marine and may not be distributed or copied, digitally or otherwise, without the prior written consent of Mercury Marine.

NOTE: The three long screws reach into the seawater pump bracket.

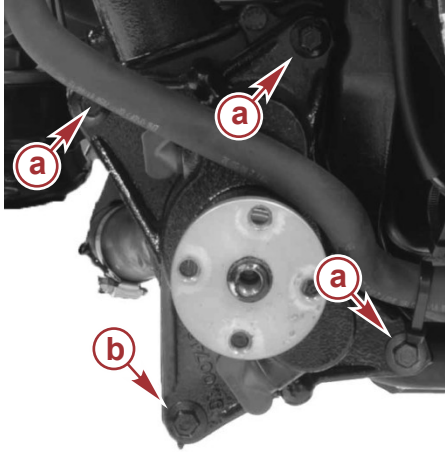

- Pulley removed for clarity**
a - M8 x 35 screws (3)
b - M8 x 20 screw (1)

62232

Description	Nm	lb-in.	lb-ft
Seawater pump cover screws	24	-	17.7

THE INFORMATION IN THIS DOCUMENT IS CONFIDENTIAL AND PROTECTED BY COPYRIGHT AND IS THE PROPERTY OF MERCURY MARINE.

This document is provided for the sole and exclusive use of the original recipient as prescribed by Mercury Marine and may not be distributed or copied, digitally or otherwise, without the prior written consent of Mercury Marine.

THE INFORMATION IN THIS DOCUMENT IS CONFIDENTIAL AND PROTECTED BY COPYRIGHT AND IS THE PROPERTY OF MERCURY MARINE.

This document is provided for the sole and exclusive use of the original recipient as prescribed by Mercury Marine and may not be distributed or copied, digitally or otherwise, without the prior written consent of Mercury Marine.