



# Service Bulletin

Bulletin No. 2010-73  
CMD 2010-13

Circulate to:  Sales Manager  Accounting  Service Manager  Technician  Parts Manager

## Official Recall Notification Under the U.S. Federal Boat Safety Act

## Replacement of the Core Wire of the Intermediate Shift Cable on Mercury MerCruiser Alpha and Bravo Sterndrives

### Scope

Worldwide.

### Models Affected

CMD Sterndrive Models With Transoms in the Following Serial Number Ranges	Transom Serial Number
Alpha	1A194127–1A468107
Bravo	1A437945–1A444913

**NOTE:** Transoms may be part of a CMD power package or other diesel-powered package, or may have been sold as a service replacement part. All transoms within the above serial number ranges are subject to this recall.

Shift Cables Obtained as a Service Replacement Part	Shift Cable	Shift Cable Kit
Alpha	865436A02	865436A03
Bravo	865437A02	815471T1

Any replacement cable or cable kit with a box date (as identified on the box) before February 11, 2010 or after June 23, 2010 is not affected by this recall. If the cable has a box date within this range, the date code on the cable itself will determine whether the cable is affected by this recall.

THE INFORMATION IN THIS DOCUMENT IS CONFIDENTIAL AND PROTECTED BY COPYRIGHT AND IS THE PROPERTY OF MERCURY MARINE.

This document is provided for the sole and exclusive use of the original recipient as prescribed by Mercury Marine and may not be distributed or copied, digitally or otherwise, without the prior written consent of Mercury Marine.

## Identifying Affected Shift Cables Obtained as Replacement Parts

To determine whether a replacement shift cable is affected by this recall, find the cable date code stamped on the barrel of the cable jacket on the shift-bracket end of the cable.

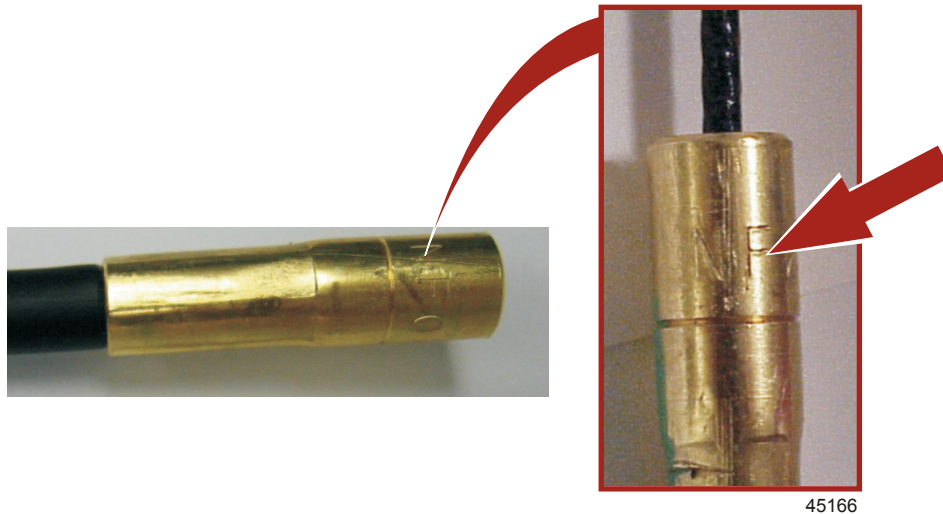

Date code stamp

## Date Codes of Cables Affected by This Recall

**IMPORTANT:** The date code range for affected cables is NB111–NF141.

All affected cables have N as the first character and B–F (February–June) as the second character.

First Character	Second Character	Third and Fourth Characters	Fifth Character
Year Code	Month Code	Day of the Month	Shift Number
N	B, C, D, E, F	00–31	1–3

For example, the following table shows how to interpret a cable that has the date code **NF182**.

Character	Description
N	2010
F	June
18	18th day
2	Second shift

## Situation

The core fitting may not remain attached to the core wire. If the core fitting is detached from the core wire, shift control will be lost. Replacement of the core wire of the intermediate shift cable should be scheduled and completed as soon as possible. The boat should not be operated until the repair has been completed.

## Correction

Replace the core wire of the intermediate shift cable. Follow the appropriate procedures for replacing the core wire in **How to Replace the Core Wire**.

Some cables have been corrected in production. Boat builders and dealers in the United States and Canada: use MercNET to determine whether the wire has already been repaired. First search under the engine serial number. If this recall is not listed with the engine serial number, search under the transom serial number.

THE INFORMATION IN THIS DOCUMENT IS CONFIDENTIAL AND PROTECTED BY COPYRIGHT AND IS THE PROPERTY OF MERCURY MARINE.

This document is provided for the sole and exclusive use of the original recipient as prescribed by Mercury Marine and may not be distributed or copied, digitally or otherwise, without the prior written consent of Mercury Marine.

## Identification of corrected shift cables

Cables in transoms within the affected serial number range or cables within the date codes have been repaired if they are marked with a green or blue paint dot on the cable end. Corrected cables are now being marked with a green paint stripe on the barrel of the cable jacket or a stripe of green tape around the outside of the cable housing at the engine end of the cable. If this green marking is present, core wire replacement is not necessary. Some cables did not receive the paint mark on the outer cable. If the paint dot is present on the core wire end but not on the outer cable, the cable is still good. Add a mark to the outer cable and submit a claim for inspection without replacement.



45159

**Green or blue dot on the end of the core wire indicates a corrected core wire**

Corrected cables have been marked on the outer housing at the engine end to signify that the inner core wire has been changed.

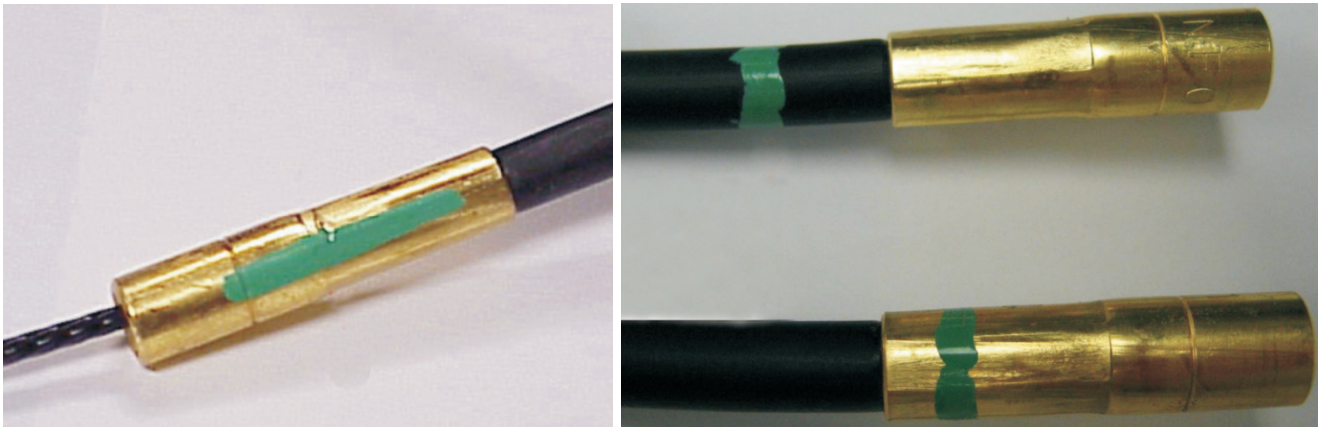

45171

**Various markings to indicate a corrected cable**

THE INFORMATION IN THIS DOCUMENT IS CONFIDENTIAL AND PROTECTED BY COPYRIGHT AND IS THE PROPERTY OF MERCURY MARINE.

This document is provided for the sole and exclusive use of the original recipient as prescribed by Mercury Marine and may not be distributed or copied, digitally or otherwise, without the prior written consent of Mercury Marine.

## Replacement of the Core Wire of the Intermediate Shift Cable on Mercury MerCruiser Alpha and Bravo Sterndrives

Boat builders have been painting a silver stripe around the cable behind the brass ferrule at the engine end of the cable to signify that the inner core wire has been changed. Regardless of the color used on the outer cable housing, the inner core wire is identified with a green or blue paint dot on the end.

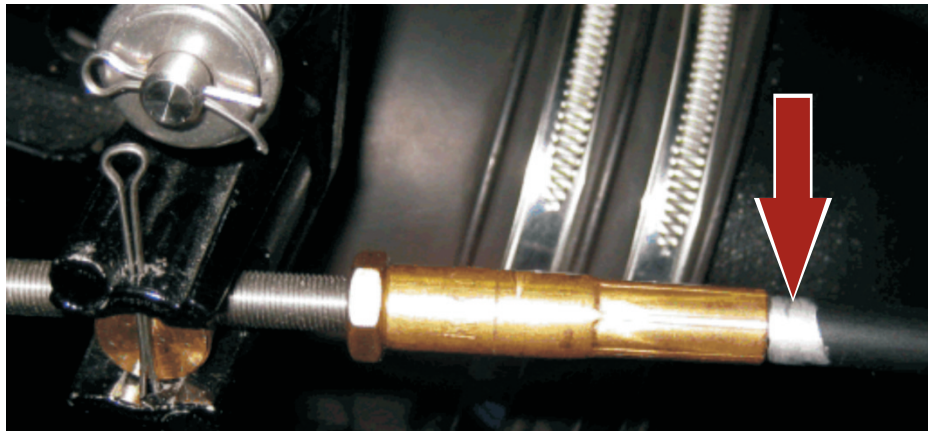

45170

**Dealers:** Mark the outer cable at the engine end as shown with a white paint line.

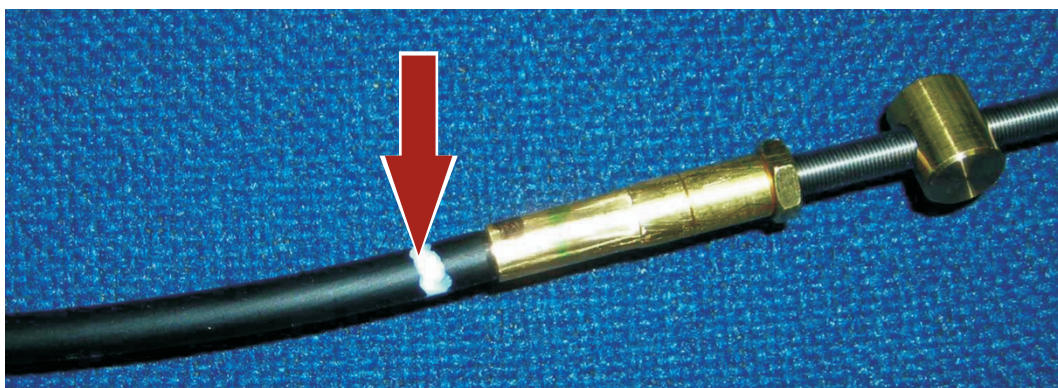

45172

**NOTE:** All transoms with serial numbers below the affected range listed and all individual cables with date codes earlier than February 11, 2010 have good cables. All transoms built after the ending serial number, loose cables manufactured after the final date code, or any cable that has been repaired will have a green or blue paint dot on the end of the core wire. Normally Mercury requires replacement of the inner and outer shift cable assembly. Because these intermediate shift cables have little or no wear, it is acceptable to replace the core wire only.

## Replacement Parts

Qty	Description	Part Number
1	Alpha and MC1 shift cable core wire	865435
1	Bravo shift cable core wire	865438
1	If removing an Alpha drive: gasket	94996Q2

## How to Replace the Core Wire

**IMPORTANT:** Refer to the appropriate sterndrive service manual for instructions on removal, installation, and adjustment of shift cables. After replacing the core wire, add the paint stripe to the engine end of the cable to enable easy identification in the future.

## Removal—Alpha Models

**NOTE:** See the appropriate MerCruiser sterndrive service manual for sterndrive removal, installation, and shift cable adjustment procedures.

THE INFORMATION IN THIS DOCUMENT IS CONFIDENTIAL AND PROTECTED BY COPYRIGHT AND IS THE PROPERTY OF MERCURY MARINE.

This document is provided for the sole and exclusive use of the original recipient as prescribed by Mercury Marine and may not be distributed or copied, digitally or otherwise, without the prior written consent of Mercury Marine.

## Replacement of the Core Wire of the Intermediate Shift Cable on Mercury MerCruiser Alpha and Bravo Sterndrives

1. Remove the sterndrive from the transom assembly.
2. Disconnect intermediate shift cable from the shift plate, loosen the end guide anchor screws, and remove the end guide from the shift cable.

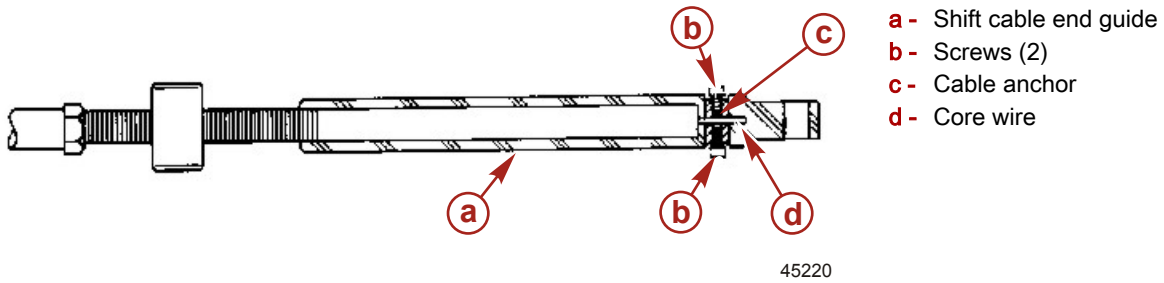

3. Cut the safety wire and remove the screw from the shift slide.

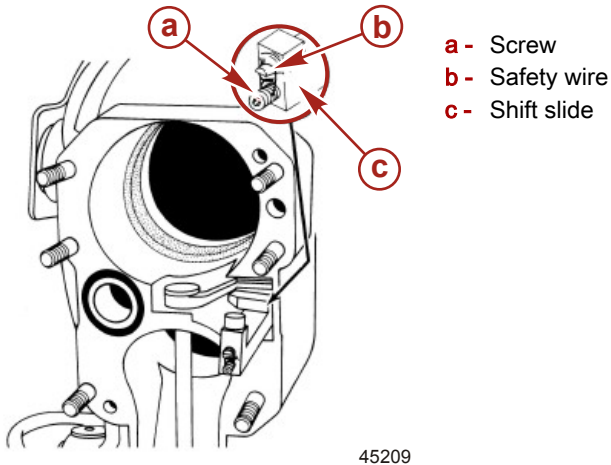

4. Remove the shift slide from the bell housing while pulling the core wire through the transom assembly.

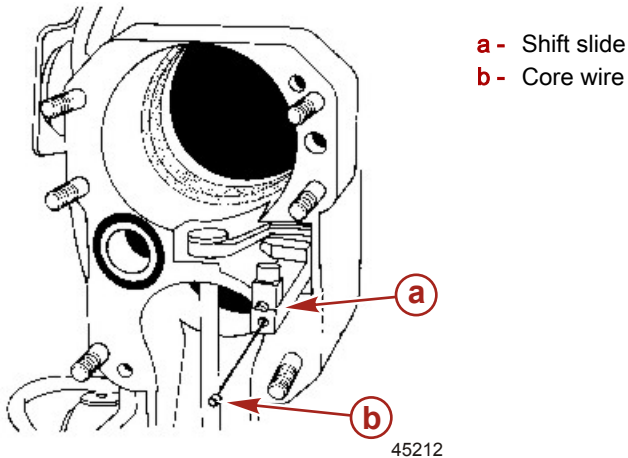

5. Remove the core wire from the shift slide.

THE INFORMATION IN THIS DOCUMENT IS CONFIDENTIAL AND PROTECTED BY COPYRIGHT AND IS THE PROPERTY OF MERCURY MARINE.

This document is provided for the sole and exclusive use of the original recipient as prescribed by Mercury Marine and may not be distributed or copied, digitally or otherwise, without the prior written consent of Mercury Marine.

## Installation—Alpha Models

1. Install the new core wire through the shift slide.

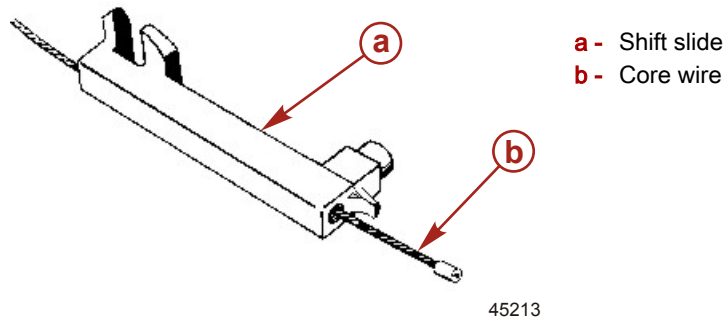

2. Install the set screw into the shift slide and turn until it contacts the core wire end, then back the screw out a maximum of 1/8 turn.  
**IMPORTANT: The shift slide assembly must be free to rotate on the core wire.**
3. Using a figure-eight pattern, secure the screw to the shift slide with safety wire. Twist until tight and trim the excess safety wire with wire cutters.
4. Insert the core wire into the shift cable jacket located in the bell housing shift cavity.
5. Continue to push the core wire through the transom assembly until the shift slide is positioned on the shift cable tube inside the bell housing shift cavity.  
**IMPORTANT: Ensure that shift slide remains in an upright position and is properly engaged with the shift shaft lever roller.**
6. Install the sterndrive.  
**NOTE: If the sterndrive is not to be installed at this time, make the barrel adjustment at the time of installation.**
7. Push in on the drive unit shift cable while turning the propeller shaft counterclockwise until the shaft stops. To ensure that the clutch is fully engaged, maintain pressure on the propeller shaft with a suitable device, such as an elastic strap.

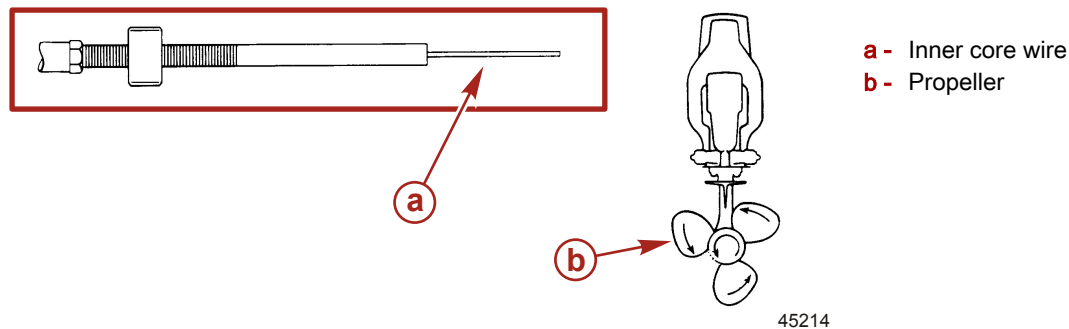

8. Install the shift cable end guide over the core wire (shift bracket end) and insert the core wire through the cable anchor.  
**IMPORTANT: The core wire must be completely inserted through the anchor.**
9. Tighten the anchor screws securely.

THE INFORMATION IN THIS DOCUMENT IS CONFIDENTIAL AND PROTECTED BY COPYRIGHT AND IS THE PROPERTY OF MERCURY MARINE.

This document is provided for the sole and exclusive use of the original recipient as prescribed by Mercury Marine and may not be distributed or copied, digitally or otherwise, without the prior written consent of Mercury Marine.

- While applying light inward pressure, rotate the barrel on the shift cable threads until the distance between the center of the hole in the shift cable end guide and the center of the brass barrel measures 153 mm (6.0 in.).

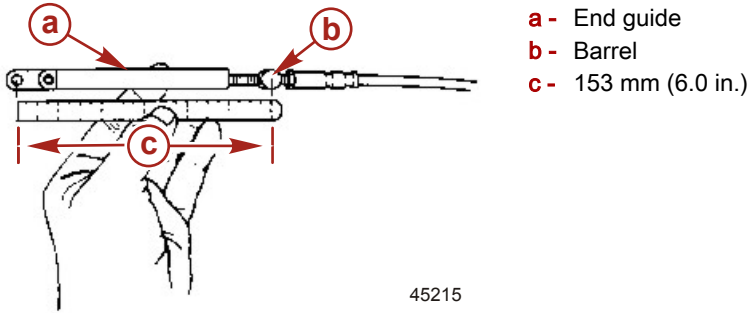

- Install the shift cable onto the shift plate.
- Verify shift adjustment.

## Removal—Bravo Models

- Remove the sterndrive from the transom assembly.
- Remove the intermediate shift cable from the shift plate.
- Locate the shift cable end guide that was removed from the engine shift plate.
- Loosen both set screws.
- Pull the shift cable end guide from the shift cable.

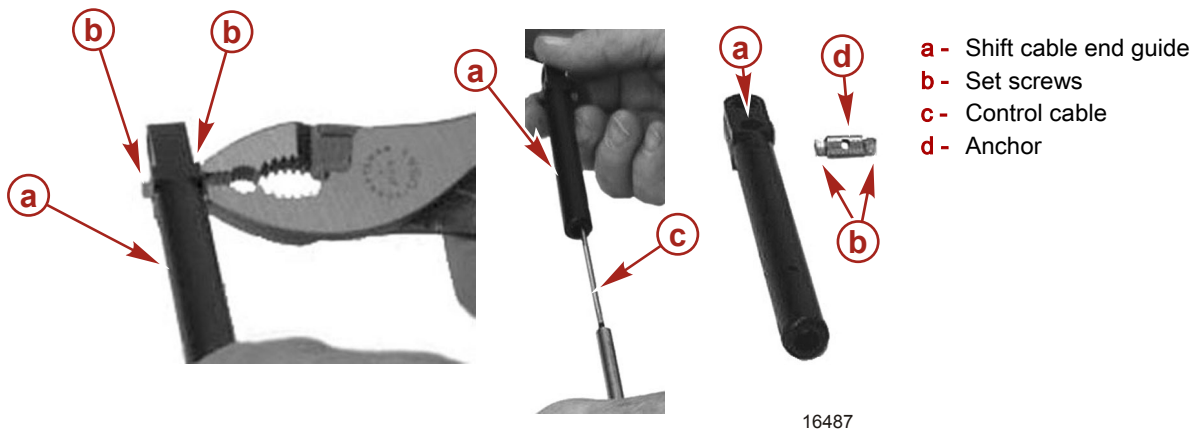

- Pull the core wire from the intermediate shift cable cavity in the bell housing.

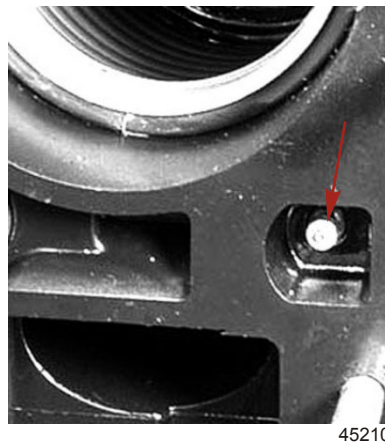

Core wire end

THE INFORMATION IN THIS DOCUMENT IS CONFIDENTIAL AND PROTECTED BY COPYRIGHT AND IS THE PROPERTY OF MERCURY MARINE.

This document is provided for the sole and exclusive use of the original recipient as prescribed by Mercury Marine and may not be distributed or copied, digitally or otherwise, without the prior written consent of Mercury Marine.

## Installation—Bravo Models

1. Install the new core wire into the shift cable cavity in the bell housing.
2. Install the control cable through the shift cable end guide.
3. Allow the core wire to enter through the anchor in the shift cable end guide.

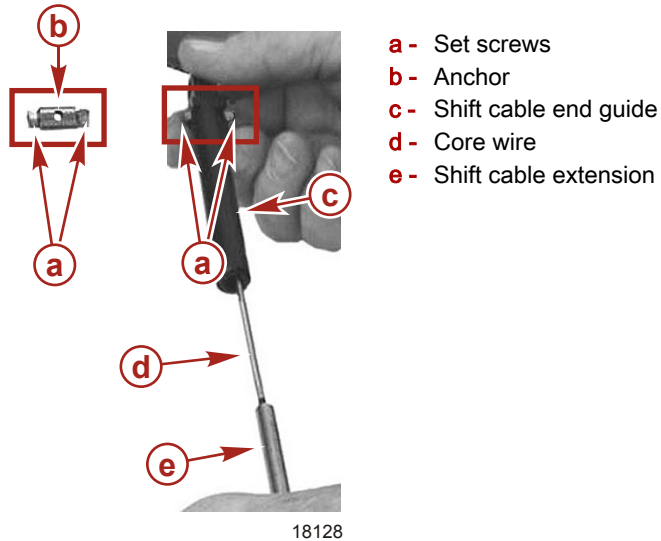

4. Tighten the set screws on the anchor to secure the core wire.

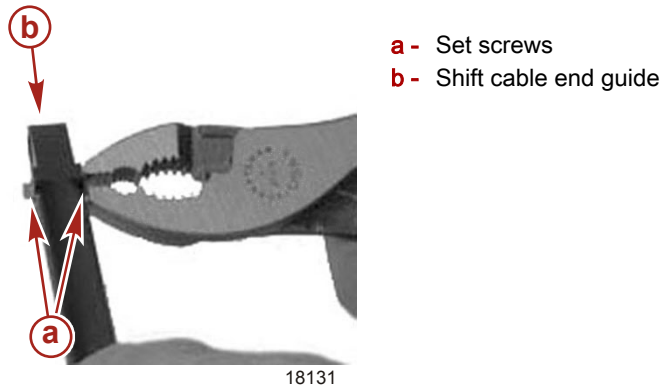

5. Pull the shift cable end guide to ensure the control cable connection is secure.

THE INFORMATION IN THIS DOCUMENT IS CONFIDENTIAL AND PROTECTED BY COPYRIGHT AND IS THE PROPERTY OF MERCURY MARINE.

This document is provided for the sole and exclusive use of the original recipient as prescribed by Mercury Marine and may not be distributed or copied, digitally or otherwise, without the prior written consent of Mercury Marine.



## Shift Cable Adjustment

1. Install the core wire locating tool onto the face of bell housing.

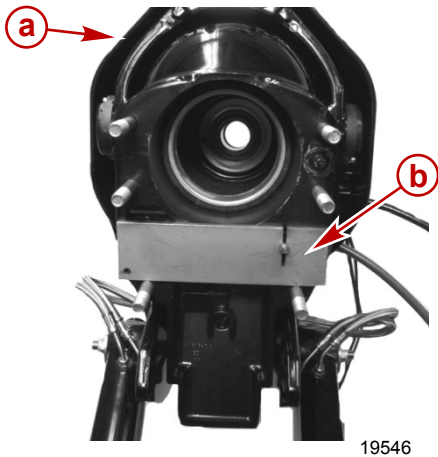

- a - Bell housing
- b - Core wire locating tool

Shift cable anchor adjustment tool	91-17262A1
<p>91-17262 91-17263 10687</p>	Use to set the shift cable adjustments after shift cable installation. Includes the following components: 91-17262A1 Core wire locating tool 91-17263 Shift cable anchor adjustment tool

2. Place the shift cable anchor adjustment tool on the end of the shift cable.

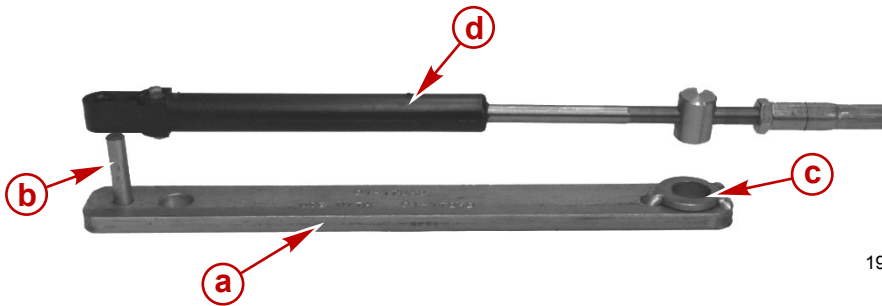

- a - Shift cable anchor adjustment tool
- b - Stud
- c - Hole (barrel placed here)
- d - Shift cable assembly

Shift cable anchor adjustment tool	91-17262A1
<p>91-17262 91-17263 10687</p>	Use to set the shift cable adjustments after shift cable installation. Includes the following components: 91-17262A1 Core wire locating tool 91-17263 Shift cable anchor adjustment tool

THE INFORMATION IN THIS DOCUMENT IS CONFIDENTIAL AND PROTECTED BY COPYRIGHT AND IS THE PROPERTY OF MERCURY MARINE.

This document is provided for the sole and exclusive use of the original recipient as prescribed by Mercury Marine and may not be distributed or copied, digitally or otherwise, without the prior written consent of Mercury Marine.

3. Ensure that bell housing end of core wire is positioned tightly against the core wire locating tool.

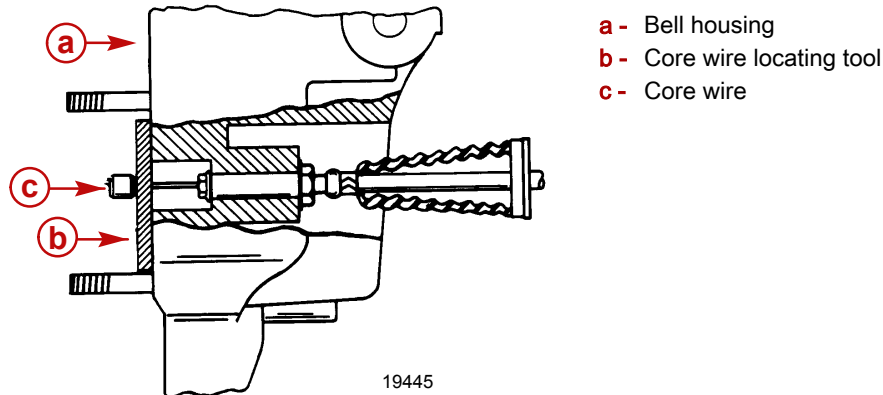

4. Adjust the cable barrel to align with the hole in the tool.

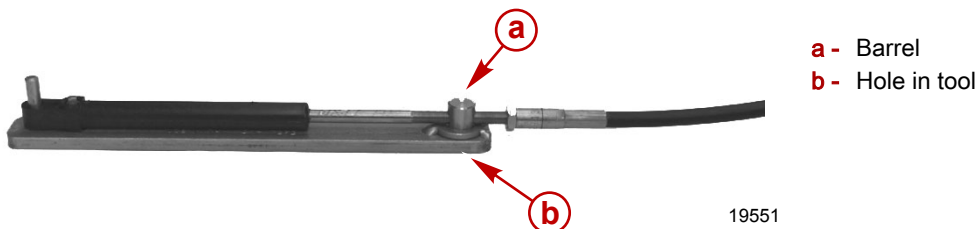

5. Follow the procedures in **Service Manual #39 – Bravo Sterndrives** for final shift cable adjustment and sterndrive installation.

## Owner Notification

All registered owners within the affected serial number range will receive a letter from Mercury Marine. This letter will explain the situation and request that they contact their local dealer to set up a time to have this inspection performed. A copy of this letter is included with this bulletin.

## Warranty

Mercury Marine will credit the dealer for the cost of the part and the labor. Submit a warranty claim through your normal warranty-processing channel, providing the following information, as applicable:

1. MerCruiser engine serial number. Add the transom serial number to the claim text.
2. Work order to provide proof of installation of service parts.
3. Flat rate code and labor
  - For inspection without cable replacement:
    - For a replacement cable installed after February 11, 2010
    - For engines and transoms within an affected serial number range
      - If the inspection required removal of the sterndrive unit: Flat Rate Code: SB10; Labor: 1.0 hr
      - If the inspection did not require removal of the sterndrive unit: Flat Rate Code: SB05; Labor: 0.5 hr
  - For inspection and replacement of a core wire:
    - Installed in a boat with a drive: Flat Rate Code: SB18; Labor: 1.8 hr (includes 1.0 hr to remove and replace drive)
    - If the transom is not installed or the drive is not installed on the boat: Flat Rate Code: SB04; Labor: 0.4 hrs
    - If the cable is in the box: no time is allowed
    - Part code: 221
    - Failure code: 40
4. The appropriate serial number for tracking the repair:
  - If the transom assembly is a service part or is part of CMD or other diesel power package, submit the claim against the transom serial number.
  - If the cable is a service part, submit the claim against the original engine serial number.

THE INFORMATION IN THIS DOCUMENT IS CONFIDENTIAL AND PROTECTED BY COPYRIGHT AND IS THE PROPERTY OF MERCURY MARINE.

This document is provided for the sole and exclusive use of the original recipient as prescribed by Mercury Marine and may not be distributed or copied, digitally or otherwise, without the prior written consent of Mercury Marine.

- For packaged cables in inventory, submit a P&A claim. Replace the core wire and keep the shift cable assembly in stock.

## Old Part

- **In the United States and Canada:** Cut the core wire in half with wire cutters to prevent possible use by mistake, and then scrap.
- **Outside the United States and Canada:** Follow instructions issued by your Marine Power International office or by your distributor.

THE INFORMATION IN THIS DOCUMENT IS CONFIDENTIAL AND PROTECTED BY COPYRIGHT AND IS THE PROPERTY OF MERCURY MARINE.

This document is provided for the sole and exclusive use of the original recipient as prescribed by Mercury Marine and may not be distributed or copied, digitally or otherwise, without the prior written consent of Mercury Marine.

## **NOTICE FOR RECALL UNDER THE U.S. FEDERAL BOAT SAFETY ACT**

Dear CMD Customer:

Thank you for your purchase of a new boat powered by a CMD engine. We appreciate your business and hope everything is performing up to your expectations.

As part of our commitment to superior customer satisfaction, we have determined that it is necessary to replace the core wire of the intermediate shift cable to ensure the durability of your CMD package. It is possible that a core fitting may not remain attached to the core wire. If the cable end comes loose, the ability to shift the drive unit out of its current gear position (forward, neutral, or reverse) will be gone without notice to the operator. Failure of the shift cable, if it occurs, will not cause the throttle function to fail. The replacement of this core wire should be scheduled and completed at the earliest possible time. Do not operate the boat until repairs have been completed.

### **What should you do?**

Contact your CMD dealer or distributor and make arrangements for the repair. There will be no cost for the repair to you. If you have any questions or no longer own this boat, please contact CMD Customer Service for assistance at +1 800 343 7357. The dealer or distributor will refer to CMD Service Bulletin 2010-13 for instructions on replacing the core wire. CMD will reimburse the dealer or distributor for performing this recall in accordance with the instructions outlined in the Service Bulletin.

CMD apologizes for any inconvenience this recall may cause you. However, we have taken this action to ensure that your boating experience will be enjoyable and trouble-free.

Sincerely,

CMD Customer Service