



Service Bulletin

Bulletin No. 2010-64
CMD 2010-04

Circulate to: Sales Manager Accounting Service Manager Technician Parts Manager

Improved Propshaft Seal for CMD Bravo Three Sterndrives

Models Affected

All Bravo Three sterndrives

Situation

New Bravo Three sterndrive installations may require as much as 470 mL (16 fl oz) of gear lube added to the monitor bottle during the break-in period (first 20 hours of operation). It is important to monitor and maintain the gear lube level during the break-in period.

Cummins MerCruiser Diesel (CMD) has received reports of a drop in the level of gear lube in Bravo Three sterndrives after the break-in period. To determine if the sterndrive is leaking, refer to **Sterndrive Pressure Test**. A leak could be the result of the inner propeller shaft seal leaking gear lube.

IMPORTANT: The gear lube level fluctuates during operation. The gear lube monitor must be checked and filled if necessary at the beginning of each day when the engine is cold. If the gear lube alarm sounds during the day's activity, add the appropriate amount of gear lube to the monitor bottle.

Correction

A new inner propeller shaft seal with improved sealing characteristics has been developed. A new seal removal tool is also available which makes it easier to remove the inner propeller shaft seal without damaging the needle bearings behind the seal. Refer to **CMD Service Bulletin 2009-14**.

For inner propeller shaft seal removal and installation instructions, refer to **Service Manual #39 Bravo Sterndrive**.

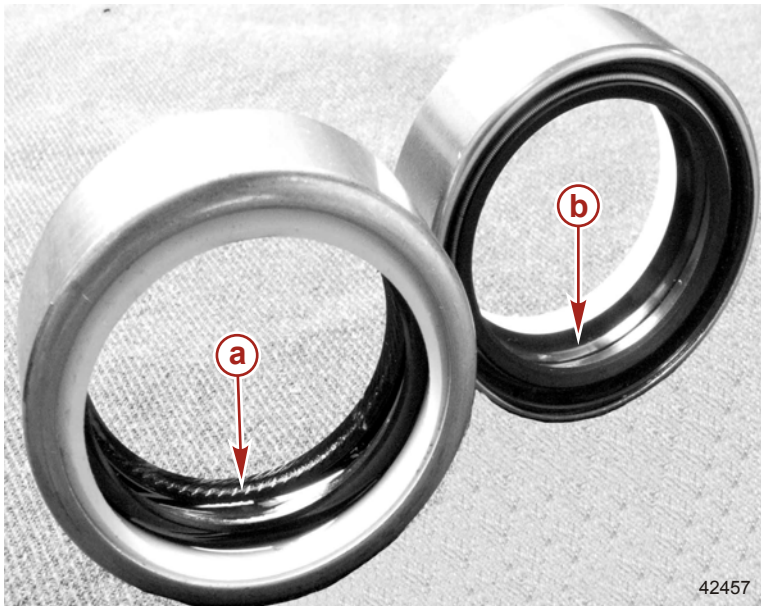

- a - Original-design Bravo Three inner propeller shaft oil seal with helix pattern on seal face.
- b - New-design Bravo Three inner propeller shaft oil seal without helix pattern on seal face.

THE INFORMATION IN THIS DOCUMENT IS CONFIDENTIAL AND PROTECTED BY COPYRIGHT AND IS THE PROPERTY OF MERCURY MARINE.

This document is provided for the sole and exclusive use of the original recipient as prescribed by Mercury Marine and may not be distributed or copied, digitally or otherwise, without the prior written consent of Mercury Marine.

Description	Previous Part Number	New Part Number
Bravo Three inner propeller shaft seal	26-861695	26-8M0033407
Seal removal tool	–	8M2013914

Sterndrive Pressure Test

NOTICE

Discharge of oil, coolant, or other engine/drive fluids into the environment is restricted by law. Use caution not to spill oil, coolant, or other fluids into the environment when using or servicing your boat. Be aware of the local restrictions governing the disposal or recycling of waste, and contain and dispose of fluids as required.

IMPORTANT: If any water drains from the unit, or if the gear lube appears milky, the sterndrive unit is leaking.

IMPORTANT: Do not vacuum-test the sterndrive.

NOTE: This test is performed with the sterndrive installed on the vessel. The drive unit is checked at two different pressures because leaks can often occur at one pressure but not the other.

1. Remove the propellers. Refer to **Service Manual #39 Bravo Sterndrive**.
2. Prepare a solution of liquid soap (1/4 cup) and water in a hand-pump spray bottle. Adjust the spray bottle nozzle to mist.
3. Remove the gear lube monitor from its bracket.
4. Remove the cap and empty the contents of the gear lube monitor into a suitable container.
5. Install the gear lube monitor.
6. Place the sterndrive unit in full trim out position.
7. Remove the gear lube fill and drain screw and sealing washer.
8. Drain the gear lube into a suitable container.

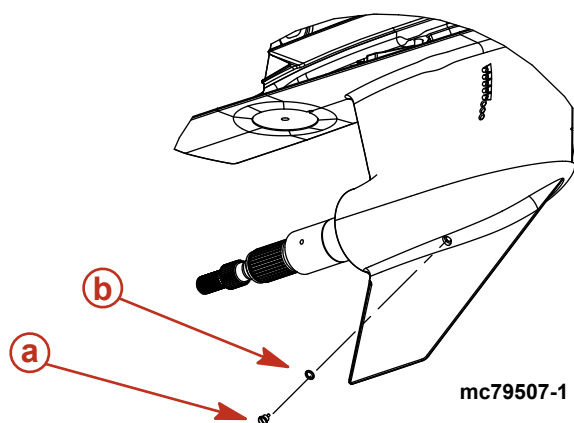

- a - Gear lube fill and drain screw
- b - Sealing washer

9. After allowing the top of the drive to empty, remove the oil vent screw and sealing washer. Allow the gear lube to drain completely.

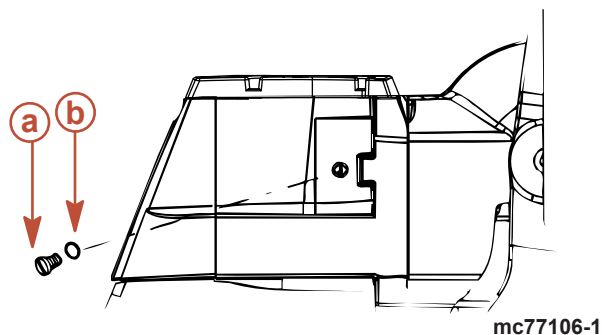

- a - Oil vent screw
- b - Sealing washer

10. Install the gear lube monitor cap.
11. Install the gear lube fill and drain screw.

THE INFORMATION IN THIS DOCUMENT IS CONFIDENTIAL AND PROTECTED BY COPYRIGHT AND IS THE PROPERTY OF MERCURY MARINE.

This document is provided for the sole and exclusive use of the original recipient as prescribed by Mercury Marine and may not be distributed or copied, digitally or otherwise, without the prior written consent of Mercury Marine.

12. Lower the sterndrive unit so the propeller shaft is level.
13. Install an air pressure gauge and regulated air valve assembly into the oil vent screw hole. Obtain these parts locally.



Typical pressure gauge, regulator, and fittings

NOTE: As an alternative you may use a hand-pumped gearcase pressure tester (not shown) . Follow the manufacturer's instructions.

14. Connect an air supply hose to the air pressure gauge and regulated air valve assembly.
15. Open the regulator and apply the specified pressure to the gear housing assembly.

Pressure test of the gear housing	
Duration of test	5 minutes
Applied air pressure	48–69 kPa (7–10 psi)

16. With the drive in a gear, rotate the driveshaft while the sterndrive is pressurized to check for leaks. Refer to the appropriate **Manual Engine Rotation** information.
17. If the sterndrive maintains the minimum specified pressure for five minutes, proceed to step 20.
18. If the sterndrive does not maintain the minimum specified pressure, inspect for leaks by spraying a mild liquid soap and water solution on the following locations:
 - a. Gear lube monitor cap, hose, and fittings
 - b. Quick-connect fitting for the gear lube monitor hose
 - c. Top cover
 - d. Gear case and lower unit mating surface.
 - e. Back cover
 - f. Bearing carrier
 - g. Propeller shaft seal
 - h. Gear lube fill and drain screw
19. Repair as needed.
20. Apply the specified pressure to the gear housing assembly and observe the gauge.

Pressure test of the gear housing	
Duration of test	15 minutes
Applied air pressure	103–110 kPa (15–16 psi)

21. With the drive in a gear, rotate the driveshaft while the sterndrive is pressurized to check for leaks. Refer to the appropriate **Manual Engine Rotation** information.
22. If the sterndrive does not maintain the minimum pressure as specified inspect for leaks by spraying a mild liquid soap and water solution on the following locations:
 - a. Gear lube monitor cap, hose, and fittings
 - b. Quick-connect fitting for the gear lube monitor hose
 - c. Top cover
 - d. Gear case and lower unit mating surface.
 - e. Back cover
 - f. Bearing carrier
 - g. Propeller shaft seal

THE INFORMATION IN THIS DOCUMENT IS CONFIDENTIAL AND PROTECTED BY COPYRIGHT AND IS THE PROPERTY OF MERCURY MARINE.

This document is provided for the sole and exclusive use of the original recipient as prescribed by Mercury Marine and may not be distributed or copied, digitally or otherwise, without the prior written consent of Mercury Marine.

- h. Gear lube fill and drain screw
- 23. Repair as needed.
- 24. Re-pressurize to specification and check for leaks.
- 25. Replace leaking seals as necessary. Retest the housing.

NOTE: Refer to **Service Manual #39 Bravo Sterndrive** for leaks not related to items a through h.

- 26. Remove the pressure gauge, regulator, and fittings from the driveshaft housing.
- 27. Fill the sterndrive with lubricant and install the gear lube fill and drain screw and vent and drain plug. Refer to **Service Manual #39 Bravo Sterndrive**.
- 28. Install the propellers. Refer to **Service Manual #39 Bravo Sterndrive**.

Manual Engine Rotation—2.0L

IMPORTANT: You can remove the non-operational glow plugs from the starboard side of the cylinder head to ease engine rotation. QSD model engines do not utilize glow plugs.

- 1. Remove the plugs in the glow plug holes to release compression when turning the crankshaft.

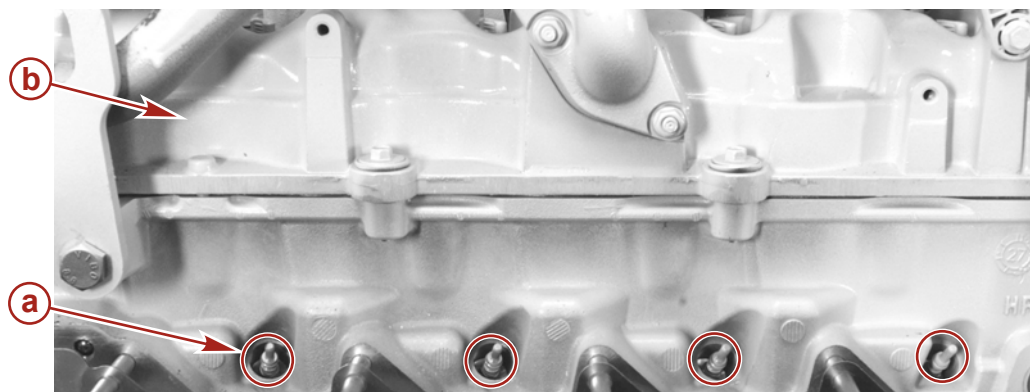

33334

- a - Glow plugs
- b - Valve cover

- 2. Attach an appropriate socket to the crankshaft pulley nut. Turn the engine with a large socket drive or breaker bar.

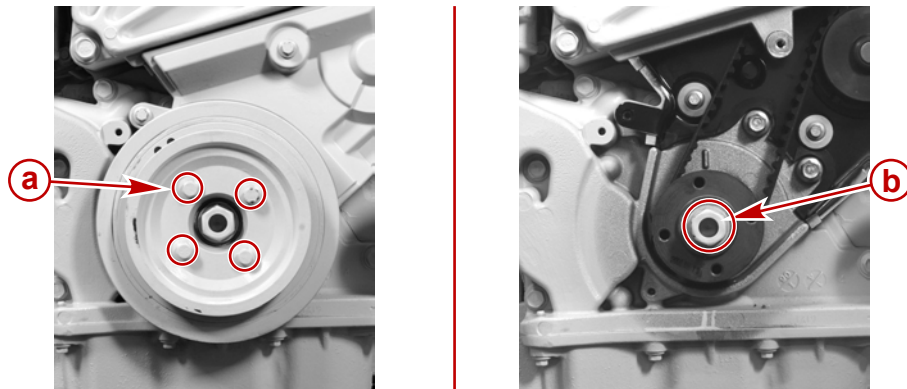

- a - Crankshaft pulley nuts
- b - Crankshaft timing sprocket with pulley removed

33335

- 3. Install any glow plugs removed during service once the service or repair is complete.

Description	Nm	lb-in.	lb-ft
Glow plug	9	80	—

THE INFORMATION IN THIS DOCUMENT IS CONFIDENTIAL AND PROTECTED BY COPYRIGHT AND IS THE PROPERTY OF MERCURY MARINE.

This document is provided for the sole and exclusive use of the original recipient as prescribed by Mercury Marine and may not be distributed or copied, digitally or otherwise, without the prior written consent of Mercury Marine.

Manual Engine Rotation—2.8

NOTE: Remove the screw plugs from the glow plug holes to release compression when turning the crankshaft. Due to their advanced computer managed fuel system, QSD model engines do not use glow plugs.

1. Remove the screw plugs in the glow plug holes to release compression when turning the crankshaft.

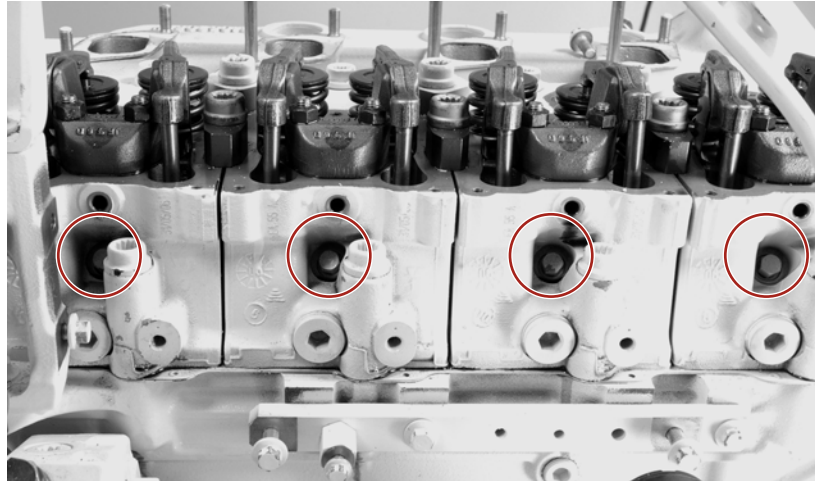

32499

Glow plug hole engine block screw plugs

2. Insert the tabs of the Crankshaft Rotation (Barring) Tool into the slots in the front of the crankshaft pulley.

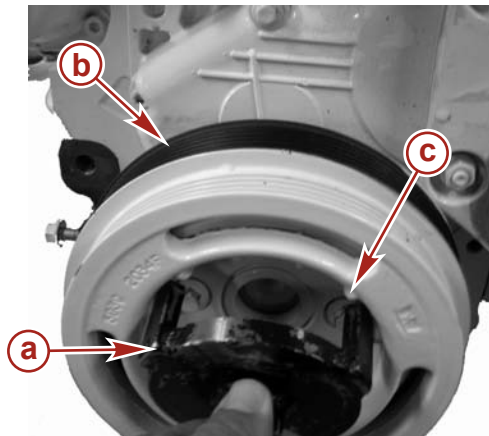

32409

2.8 engine

- a** - Barring tool
- b** - Crankshaft pulley
- c** - Slot

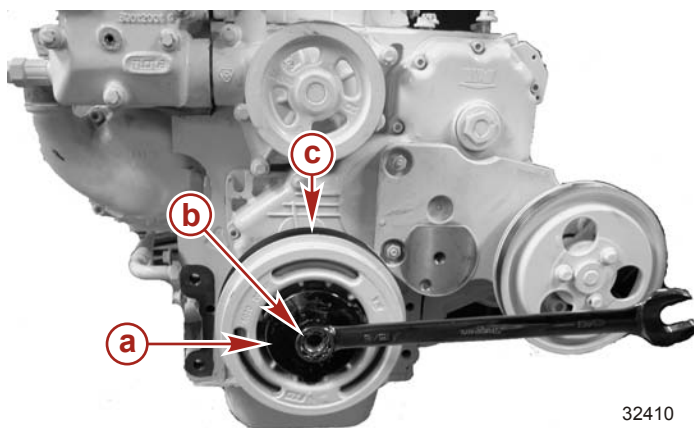

32410

- a** - Barring tool
- b** - Wrench
- c** - Crankshaft Pulley

THE INFORMATION IN THIS DOCUMENT IS CONFIDENTIAL AND PROTECTED BY COPYRIGHT AND IS THE PROPERTY OF MERCURY MARINE.

This document is provided for the sole and exclusive use of the original recipient as prescribed by Mercury Marine and may not be distributed or copied, digitally or otherwise, without the prior written consent of Mercury Marine.

Crankshaft Rotation (Barring) Tool	91-898154
 <p>17990</p>	Used to rotate the crankshaft on assembled engines.

3. Attach an appropriately sized socket to the Crankshaft Rotation (Barring) Tool. Turn the engine with a large socket drive or break-over bar.

Manual Engine Rotation—4.2L

The crankshaft balancer of the QSD 4.2L engine is not equipped with slots for the barring tool. Rotate the QSD 4.2L engine by placing the appropriately sized socket on the crankshaft balancer nut and turn the engine over with a socket drive or breaker bar.

NOTE: Remove the screw plugs from the glow plug holes to release compression when turning the crankshaft. Due to their advanced computer managed fuel system, QSD model engines do not use glow plugs.

1. Remove the glow plug hole screw plugs.

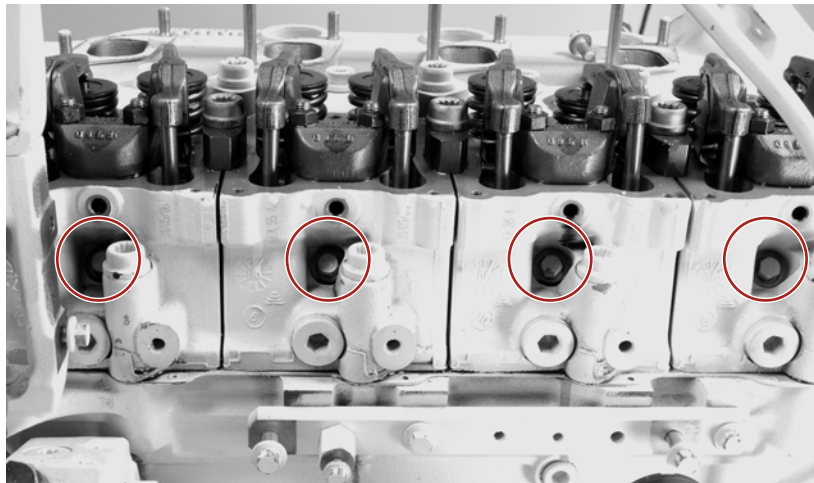

32499

Glow plug hole engine block screw plugs

2. Place a 46 mm socket on the crankshaft balancer nut.

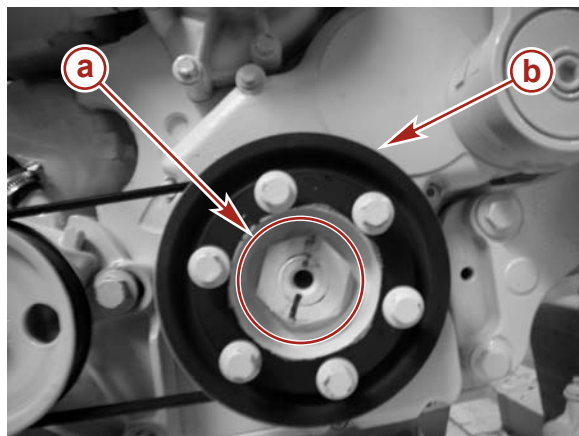

32408

- a - Crankshaft balancer nut
- b - Crankshaft balancer

3. Rotate the engine with a large socket drive or breaker bar.

Warranty

This Service Bulletin provides information and is not a recall or requirement to repair any Bravo Three sterndrive.

THE INFORMATION IN THIS DOCUMENT IS CONFIDENTIAL AND PROTECTED BY COPYRIGHT AND IS THE PROPERTY OF MERCURY MARINE.

This document is provided for the sole and exclusive use of the original recipient as prescribed by Mercury Marine and may not be distributed or copied, digitally or otherwise, without the prior written consent of Mercury Marine.

If replacement of the Bravo Three oil seals is indicated, observe standard warranty procedures. Submit the claim through your normal channel for processing warranty claims.

THE INFORMATION IN THIS DOCUMENT IS CONFIDENTIAL AND PROTECTED BY COPYRIGHT AND IS THE PROPERTY OF MERCURY MARINE.

This document is provided for the sole and exclusive use of the original recipient as prescribed by Mercury Marine and may not be distributed or copied, digitally or otherwise, without the prior written consent of Mercury Marine.