

Circulate to: Sales Manager Accounting Service Manager Technician Parts Manager

Crankshaft Position Sensor Connection

Scope

Worldwide

Models Affected

Models Covered	Serial Number
MCM 5.0L, 5.7L (350 MAG), and 6.2L (377 MAG) DTS ECT engines (including Axis)	1A300000–1A653330
MIE 5.7L and 6.2L DTS ECT engines	1A090000–1A092904

Situation

The connection between the engine wiring harness and the crankshaft position sensor (CPS) may not be electrically stable. The connection may not be maintaining electrical continuity on each of the three circuits that are part of that connection. The three circuits are: 5V sensor power, sensor ground, and sensor signal. If one or more of these circuits loses continuity across the connection, the PCM will no longer be able to determine crankshaft position and RPM. In this condition, the engine may fail to start, or it may misfire erratically at any RPM in the engine's operating range. The tachometer signal, generated by the CPS signal, will send erratic tachometer readings when the engine is misfiring.

The internal diagnostic program in the PCM will detect engine misfire and set diagnostic faults that can be viewed with the CDS G3 service tool. The PCM also stores historical fault data in its freeze frame buffers. The CDS G3 service tool can retrieve these frame buffers.

Possible faults related to this CPS connection issue are:

396	Engine_Misfire	396—OBDM Fault: Engine Misfire Limit Exceeded
19	Guardian_Overspeed	19—Engine RPM Exceeded Guardian Limit at Time of Fault

The presence of these faults does not necessarily mean that the CPS connection is faulty. However, the connection must be inspected and eliminated as a possible cause before performing further diagnostics.

Correction

NOTE: If the customer has not experienced the symptoms of an engine no-start or misfire, the CPS connection must still be inspected and repaired or replaced, as necessary. However, the inspection can be postponed until the next scheduled service.

⚠ WARNING

Performing service or maintenance without first disconnecting the battery can cause product damage, personal injury, or death due to fire, explosion, electrical shock, or unexpected engine starting. Always disconnect the battery cables from the battery before maintaining, servicing, installing, or removing engine or drive components.

Inspection

1. Disconnect the engine battery cables.

THE INFORMATION IN THIS DOCUMENT IS CONFIDENTIAL AND PROTECTED BY COPYRIGHT AND IS THE PROPERTY OF MERCURY MARINE.

This document is provided for the sole and exclusive use of the original recipient as prescribed by Mercury Marine and may not be distributed or copied, digitally or otherwise, without the prior written consent of Mercury Marine.

2. Disconnect the engine wiring harness connector from the crankshaft position sensor (CPS) receptacle near the torsional damper.

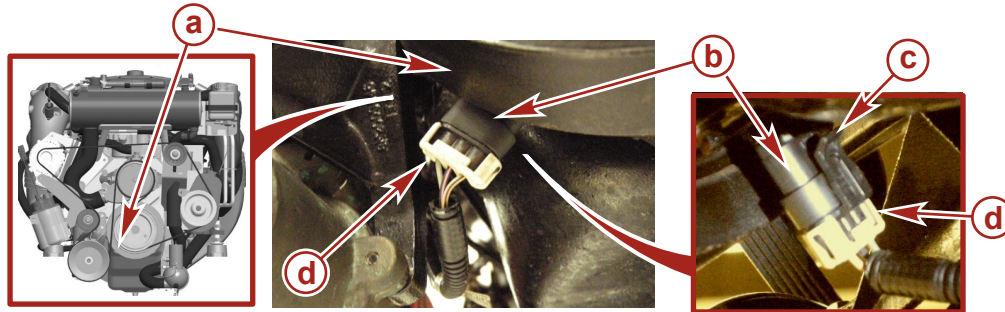

48709

- a** - Harness connector
- b** - Torsional damper
- c** - CPS receptacle
- d** - Lock tab

3. Inspect the three female terminals in the sockets of the engine wiring harness connector.
 - a. Turn the harness connector so you can see the mating end of the connector body.
 - b. Note the size of the female terminal ends visible in the opening of the connector's sockets—A, B, and C. The female terminal ends must nearly fill the socket opening and be the same size. Compare the properly formed (wide) female terminal ends (sockets A and B) with an improperly formed (narrow) terminal end socket C).

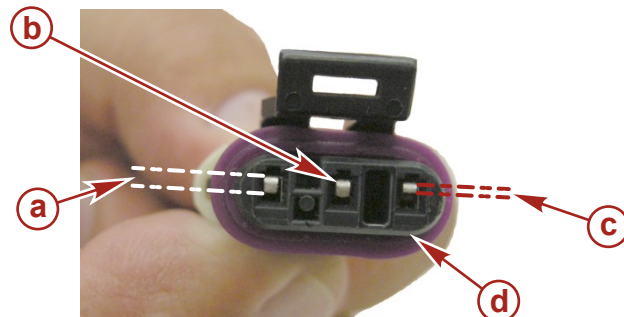

48703

Comparing terminal ends

- a** - Properly formed (wide) terminal end—socket A
- b** - Properly formed (wide) terminal end—socket B
- c** - Improperly formed (narrow) terminal end—socket C
- d** - Harness connector

4. If one or more of the female terminals in the sockets appears smaller, disassemble and repair (bend) the terminal, or terminals, back into their correct shape or replace the connector using the CPS replacement connector and wire kit.

Disassembly and Repair

1. Pry the sides of the TPA (terminal position assurance) lock away from the tangs on the connector body and remove the lock.

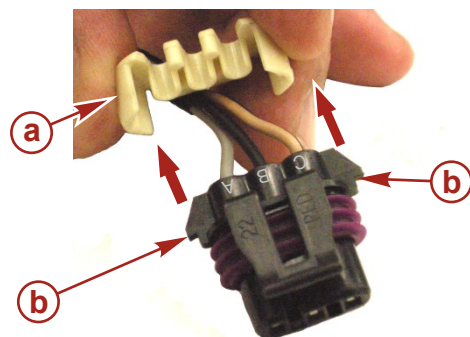

48705

2. Remove any defective female terminals from the socket.

THE INFORMATION IN THIS DOCUMENT IS CONFIDENTIAL AND PROTECTED BY COPYRIGHT AND IS THE PROPERTY OF MERCURY MARINE.

This document is provided for the sole and exclusive use of the original recipient as prescribed by Mercury Marine and may not be distributed or copied, digitally or otherwise, without the prior written consent of Mercury Marine.

- a. Grasp the wire of the improperly formed female terminal. Push the wire toward the mating end of the connector and hold it in this position.
- b. From the mating end, insert a micro-terminal pick special tool or a suitably sized tool with a tapered end of 0.90 mm (0.035 in) straight into the connector cavity channel.

Description	Part Number
Micro-terminal pick	SPX Kent Moore J-3815-12A or equivalent—obtain locally

- c. Depress the lock tang with the pick tool to depress and separate the tang from the ridge inside the cavity of the connector.
- d. Carefully pull the wire and terminal end from the back of the connector.

NOTE: The wire and terminal release easily when the locking tang is properly depressed.

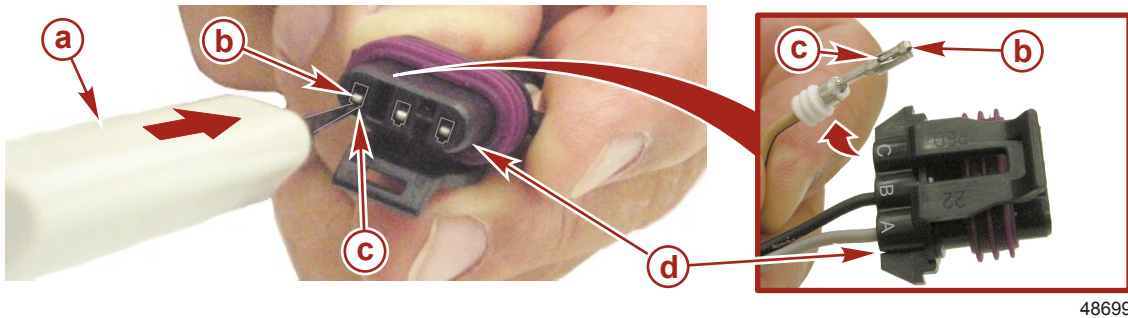

Removing a terminal

- a - Pick tool or equivalent
- b - Female terminal
- c - Locking tang
- d - Connector

3. Repair the suspect terminal socket:
 - a. Carefully bend the lock tang away from the terminal end.
 - b. Insert a suitably sized pick tool under the lock tang and into the terminal end.
 - c. Bend the tension tab until the tab fills most of the opening of the terminal while leaving space sufficient to insert the male connector during installation.

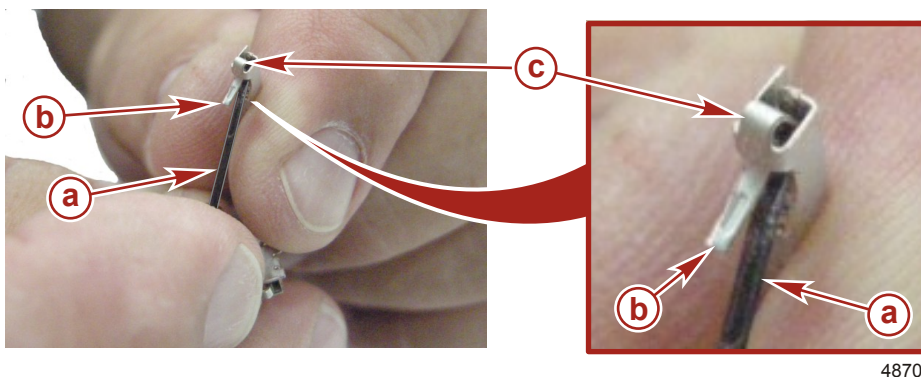

Repairing the terminal tension tab

- a - Pick tool
- b - Lock tang
- c - Tension tab

4. If the tension tab on the terminal end was repaired successfully, reassemble the connector.
 - a. Bend the lock tang back to its original position—parallel to the terminal end.
 - b. Insert the female terminal end into the connector cavity. Ensure that the lock tang enters the channel of the cavity.
 - c. Push the wire and terminal end until the lock tang slides over the ridge in the cavity of the connector.
 - d. Pull gently on the wire to ensure it is locked inside the connector.
 - e. Install the secondary lock around the tangs of the connector.
5. Connect the wiring harness CPS connector to the CPS receptacle.
6. Connect the engine battery cables to the battery.

THE INFORMATION IN THIS DOCUMENT IS CONFIDENTIAL AND PROTECTED BY COPYRIGHT AND IS THE PROPERTY OF MERCURY MARINE.

This document is provided for the sole and exclusive use of the original recipient as prescribed by Mercury Marine and may not be distributed or copied, digitally or otherwise, without the prior written consent of Mercury Marine.

Crankshaft Position Sensor Connection

7. Clear all active faults and freeze frame history faults with the CDS G3 tool.
 8. Check your repairs and verify that no faults return.
- IMPORTANT: If the terminal sockets cannot be repaired, replace the complete connector. Refer to Replacement.**

Replacement

1. If the terminal sockets cannot be repaired, order the connector and wire kit listed in the table and replace the complete connector.

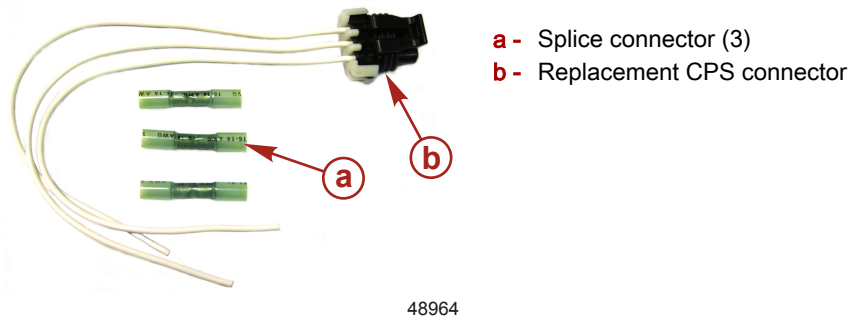

Qty.	Description	Part Number
1	Replacement CPS connector and wire kit	8M2865287

2. Follow the instructions provided with the kit and these additional steps.
 - a. After crimping each special heat-shrink splice connector, pull firmly on both wires to make sure the crimp is secure. If the crimp fails, install a new splice connector and make the crimp tighter.
 - b. When using the heat source to activate the heat-shrink tubing, ensure the tubing shrinks onto the insulation of the wires and some sealant is expelled from each end of heat shrink tubing.
3. When repairs are finished:
 - a. Connect the wiring harness CPS connector to the CPS receptacle.
 - b. Connect the engine battery cables to the battery.
 - c. Clear all active faults and freeze frame history faults with the CDS G3 tool.
 - d. Check your repairs and verify that no faults return.

IMPORTANT: If the previous options are not available or are not successful, replace the engine wiring harness. Order the correct harness as listed in the Mercury Electronic Parts Catalog. Refer to the appropriate Mercury MerCruiser service manual for installation instructions.

Warranty

United States and Canada: Submit a warranty claim through your normal warranty-processing channel, listing:

- MerCruiser engine serial number
- Flat rate codes and labor:
 - Flat Rate Code and Labor – ME-75
 - Part Code – 331
 - Failure Code – 32

Outside the United States and Canada: Follow instructions issued by your local office or by your distributor.

Old parts:

- **United States and Canada:** Return to Warranty.
- **Outside the United States and Canada:** Follow instructions issued by your local office or by your distributor.

THE INFORMATION IN THIS DOCUMENT IS CONFIDENTIAL AND PROTECTED BY COPYRIGHT AND IS THE PROPERTY OF MERCURY MARINE.

This document is provided for the sole and exclusive use of the original recipient as prescribed by Mercury Marine and may not be distributed or copied, digitally or otherwise, without the prior written consent of Mercury Marine.