

Circulate to:  Sales Manager  Accounting  Service Manager  Technician  Parts Manager

## Field Campaign on 8.2 Sterndrive ECT Engines

### Scope

Worldwide.

### Models Affected

Sterndrive Models	Serial Number
8.2 MAG ECT	1A350340–1A352732
8.2 MAG H.O. ECT	
SeaCore 8.2 MAG ECT	
SeaCore 8.2 MAG H.O. ECT	

### Situation

Mercury Marine has determined that some 8.2 Sterndrive Emission Control engine models within the Models Affected serial number range may experience a hydraulic lock after hard running conditions and keying off. This situation may prevent the engine from restarting and could damage internal engine components.

In addition, Mercury Marine is taking this opportunity to address potential fault codes set due to corrosion in the oxygen sensor connection, misfire codes due to spark plug wire damage, and a propulsion control module (PCM) replacement to address injector driver issues that may cause the injector to stick open or closed.

Also, Mercury Marine determined that the position of the clamp on the flame arrestor may have resulted in differences in the amount of torque applied to the clamp at the factory.

### Owner Notificaton

A letter will be sent to every registered owner of an affected 8.2 Sterndrive Emission Control–powered boat. The letter will advise the owner to take the boat to any Mercury MerCruiser authorized dealer for certain upgrades to the engine. Some affected power packages will have been updated before shipment. Visit MercNET or contact MerCruiser Customer Service or your regional service center to determine whether repairs have already been completed on a given package. As a Mercury MerCruiser dealer, you should also contact affected customers to make them aware of this recall and to schedule an appointment for the repair. A copy of the customer letter is attached.

### Correction

An exhaust elbow inspection, and replacement when required, coupled with the installation of the vent valve assembly are corrections intended to prevent the hydraulic lock situation.

Inspection of the oxygen sensor, oxygen sensor connections, and spark plug wires, including replacement of these components when required, is necessary to correct the potential fault code issues.

Replace the PCM when indicated. Engines without PCM replacement are required to receive a PCM reflash using the CDS G3 tool to update the calibrations and software to the latest version.

Inspecting, repositioning, and tightening the flame arrestor’s clamp to specification eliminates possible differences in the torque value applied to the clamp.

Follow the procedures in this bulletin and complete each action for an affected engine.

THE INFORMATION IN THIS DOCUMENT IS CONFIDENTIAL AND PROTECTED BY COPYRIGHT AND IS THE PROPERTY OF MERCURY MARINE.

This document is provided for the sole and exclusive use of the original recipient as prescribed by Mercury Marine and may not be distributed or copied, digitally or otherwise, without the prior written consent of Mercury Marine.

Sterndrive Models	Serial Number	Action
8.2 MAG, 8.2 MAG HO DTS 8.2 MAG, DTS 8.2 MAG HO	1A350340 – 1A352569	Inspect and replace elbow as necessary
	1A350340 – 1A352732	Install vent valve assembly
	1A350340 – 1A352424	Inspect and replace oxygen sensor connection as necessary
	1A350340 – 1A352325	Inspect and replace spark plug wires as necessary
	1A350340 – 1A351493	Reposition and torque flame arrestor clamp (DTS only)
	1A350340 – 1A351701	Replace PCM
	1A351702 – 1A352732	Reflash the PCM using the CDS G3

## Inspecting the Exhaust Elbow Riser Gap

Sterndrive Models	Serial Number
8.2 MAG ECT	1A350340–1A352569
8.2 MAG H.O. ECT	
SeaCore 8.2 MAG ECT	
SeaCore 8.2 MAG H.O. ECT	

**NOTE:** Return any unacceptable exhaust elbow to Mercury MerCruiser warranty department.

1. Turn off the engine and allow it to cool.
2. If the engine is installed, remove the exhaust bellows from the exhaust elbow.
  - a. Loosen the hose clamps on the exhaust bellows and intermediate pipe or tube.
  - b. Lubricate the intermediate pipe or tube with a soap and water solution.
  - c. Slide the bellows back and off of the exhaust elbow.
  - d. Loosen hose clamp at intermediate pipe bellows if equipped.
  - e. Lubricate the intermediate pipe or tube with a soap and water solution.
  - f. Rotate the intermediate pipe to access the aft end of the elbow.
3. Measure the gap between the exhaust inner tube and the exhaust outer tube. Measure completely around the tube.

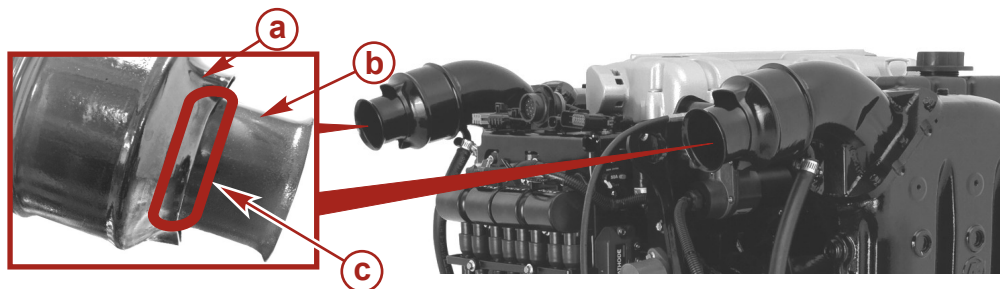

**a** - Outer tube  
**b** - Inner tube  
**c** - Measurement area (both sides)

47849

4. Attempt to insert a 0.020 in. (0.5 mm) feeler gauge between the inner tube to outer tube area.

**NOTE:** You may use a round feeler gauge for a more accurate measurement.

- **The exhaust elbow is acceptable:** If the feeler gauge does not go between the inner and outer tube of the exhaust elbow. Reassemble exhaust bellows and torque clamps.

THE INFORMATION IN THIS DOCUMENT IS CONFIDENTIAL AND PROTECTED BY COPYRIGHT AND IS THE PROPERTY OF MERCURY MARINE.

This document is provided for the sole and exclusive use of the original recipient as prescribed by Mercury Marine and may not be distributed or copied, digitally or otherwise, without the prior written consent of Mercury Marine.

- **The exhaust elbow is unacceptable:** If the feeler gauge goes between the inner and outer tube. Replace the exhaust elbow.

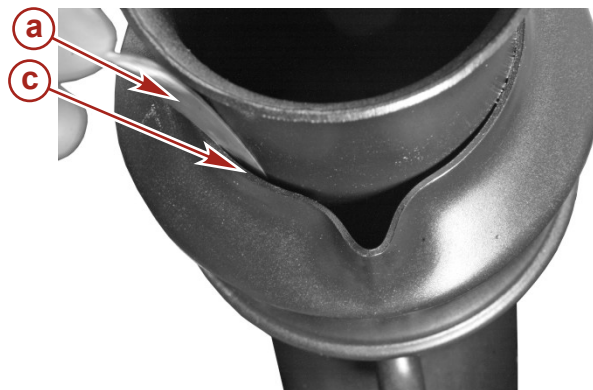

47784

**Acceptable (no action)**

- a - Feeler gauge 0.020 in. (0.5 mm)
- b - No gap (acceptable)
- c - Gap larger than feeler gauge (unacceptable)

**Unacceptable (replace elbow)**

Qty.	Description	Part Number
1 per elbow replacement	Exhaust Elbow 0" Riser	8M0058471
	Exhaust Elbow 2" Riser	8M0058472
	Exhaust Elbow 4" Riser	8M0058473
	Exhaust Elbow 6" Riser	8M0058474

### Replacing the Exhaust Elbow Riser

**⚠ WARNING**

Performing service or maintenance without first disconnecting the battery can cause product damage, personal injury, or death due to fire, explosion, electrical shock, or unexpected engine starting. Always disconnect the battery cables from the battery before maintaining, servicing, installing, or removing engine or drive components.

1. Remove the negative battery cable.
2. If the boat is in the water, close the seacock or remove the seawater hose and plug it. Refer to the **Operations, Maintenance, and Warranty Manual**.  
**IMPORTANT: Some water may remain in the exhaust manifold. Drain the exhaust elbows prior to removing components.**
3. Use the air drain system to remove the water from inside the cooling system.

THE INFORMATION IN THIS DOCUMENT IS CONFIDENTIAL AND PROTECTED BY COPYRIGHT AND IS THE PROPERTY OF MERCURY MARINE.

This document is provided for the sole and exclusive use of the original recipient as prescribed by Mercury Marine and may not be distributed or copied, digitally or otherwise, without the prior written consent of Mercury Marine.

- Remove the drain hose from the bib on the exhaust elbow. Retain the hose clamp.

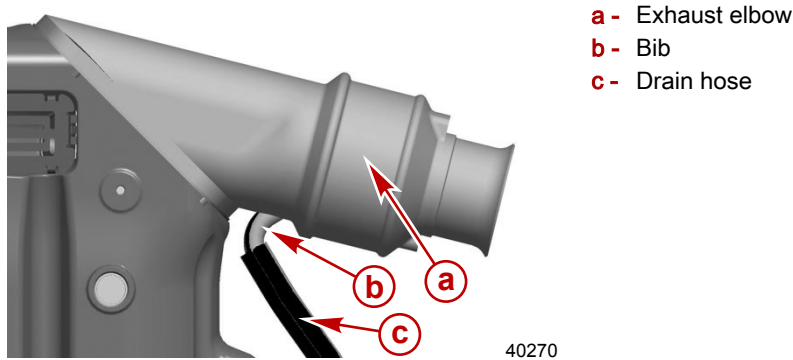

- Remove the hose from the poppet valve, note the routing and location. Remove and retain the hose clamp.
- Remove and retain the six screws securing the exhaust elbow.
- Remove and return the exhaust elbow to the MerCruiser warranty department.
- Remove and discard the gasket.
- Repeat for the other side.  
**IMPORTANT: Foreign material on hot catalysts can damage the catalysts and their ability to work properly. Prevent material from falling into the exhaust collector. If material does fall into the exhaust collector, use care when removing the material to prevent damaging the catalysts.**
- Inspect the mating surfaces before installing the new exhaust elbow riser. Clean the mating surface of the exhaust collector, if necessary.

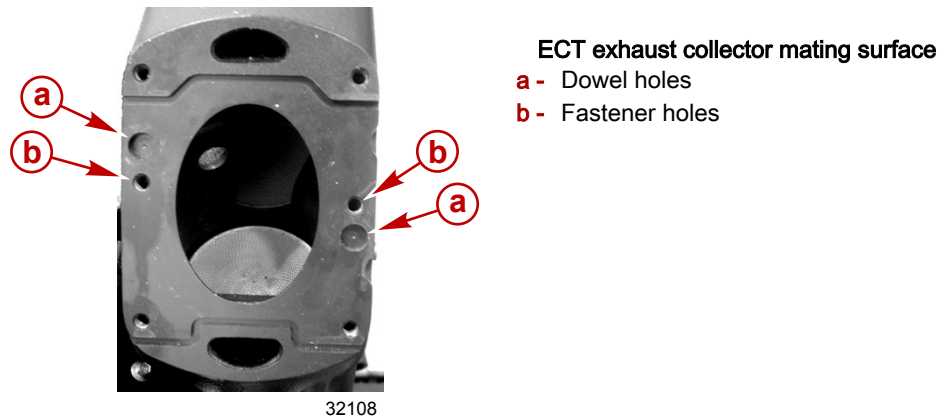

- Insert the exhaust gasket dowels into the dowel holes on the exhaust collector mating surface.

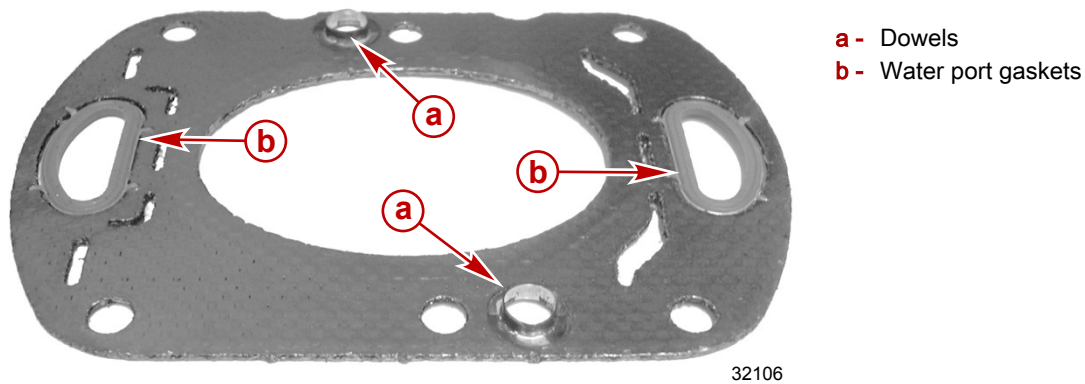

THE INFORMATION IN THIS DOCUMENT IS CONFIDENTIAL AND PROTECTED BY COPYRIGHT AND IS THE PROPERTY OF MERCURY MARINE.

This document is provided for the sole and exclusive use of the original recipient as prescribed by Mercury Marine and may not be distributed or copied, digitally or otherwise, without the prior written consent of Mercury Marine.

12. With the dowels fully seated in the dowel holes, the water ports on the exhaust collector should align with the water port gaskets. If misaligned, rotate the gasket 180°.

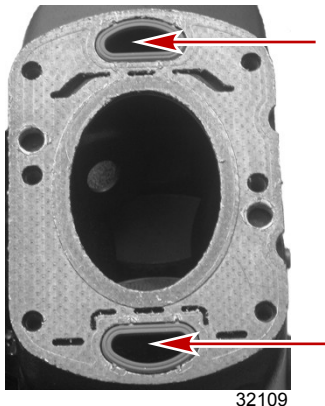

32109

**Water ports aligned**

13. Align the new exhaust elbow with the screws holes. Install the six screws.

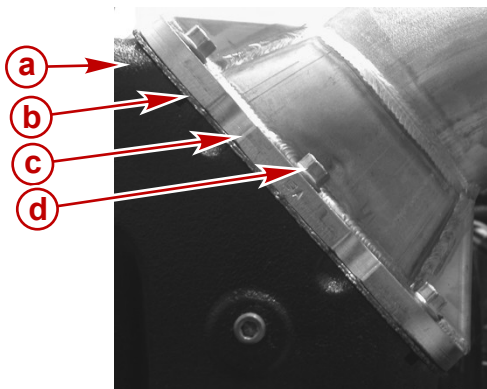

- a** - Exhaust collector
- b** - Exhaust gasket
- c** - Exhaust elbow
- d** - Screw

32110

14. Tighten the screws to specifications in the following sequence.

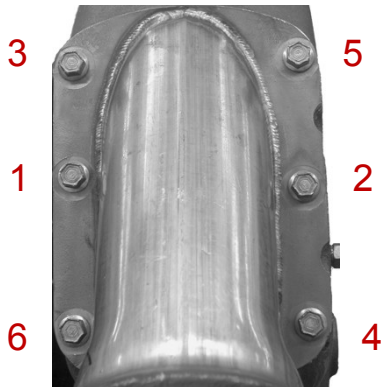

32111

Description	Nm	lb-in.	lb-ft
Screws	30	-	22

15. On standard sterndrive applications with through-the-propeller exhaust, install the exhaust bellows onto the exhaust elbow riser and intermediate exhaust elbow. Tighten both hose clamps on each joint to specification.

THE INFORMATION IN THIS DOCUMENT IS CONFIDENTIAL AND PROTECTED BY COPYRIGHT AND IS THE PROPERTY OF MERCURY MARINE.

This document is provided for the sole and exclusive use of the original recipient as prescribed by Mercury Marine and may not be distributed or copied, digitally or otherwise, without the prior written consent of Mercury Marine.

Description	Nm	lb-in.	lb-ft
Hose clamp	4-4.7	35-42	-

- On exhaust systems with water lift or through-the-hull exhaust, reconnect the exhaust system. Tighten both hose clamps on each joint to specification.

Description	Nm	lb-in.	lb-ft
Hose clamp	4-4.7	35-42	-

- Repeat the steps for the other side.
- Do not install the drain hose to the bib on the exhaust elbow riser at this time. A vent valve assembly will be installed with this drain hose in the following procedure.

## Ordering and Installing the Vent Valve

Sterndrive Models	Serial Number
8.2 MAG ECT	1A350340 – 1A352732
8.2 MAG H.O. ECT	
SeaCore 8.2 MAG ECT	
SeaCore 8.2 MAG H.O. ECT	

Install a vent valve assembly on the port and starboard exhaust elbows of the engine. The vent valve assemblies will prevent a vacuum from occurring in the exhaust system when the key is turned to the off position.

**NOTE:** One vent valve assembly is required for each exhaust elbow.

Qty.	Description	Part Number
Two per engine	Vent valve kit	8M0054663

- If not already removed, loosen the hose clamp and remove the bypass hose from the water fitting on the exhaust elbow. Allow the hose clamp to slide down the hose and out of the way.
- Cut 76 mm (3 in.) off the bypass hose open end.

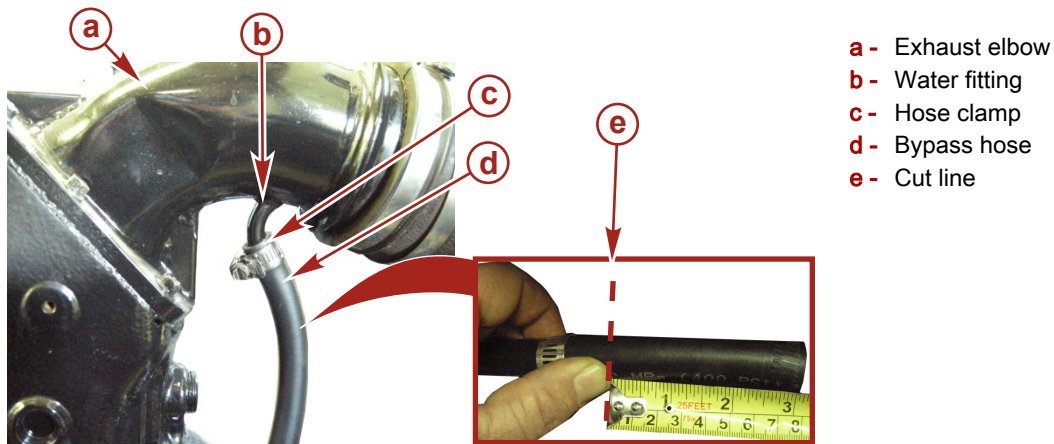

45494

THE INFORMATION IN THIS DOCUMENT IS CONFIDENTIAL AND PROTECTED BY COPYRIGHT AND IS THE PROPERTY OF MERCURY MARINE.

This document is provided for the sole and exclusive use of the original recipient as prescribed by Mercury Marine and may not be distributed or copied, digitally or otherwise, without the prior written consent of Mercury Marine.

- Push the reservoir on the exhaust elbow with the weep hole toward the outside of the engine. Position the reservoir above the water fitting on the exhaust elbow.

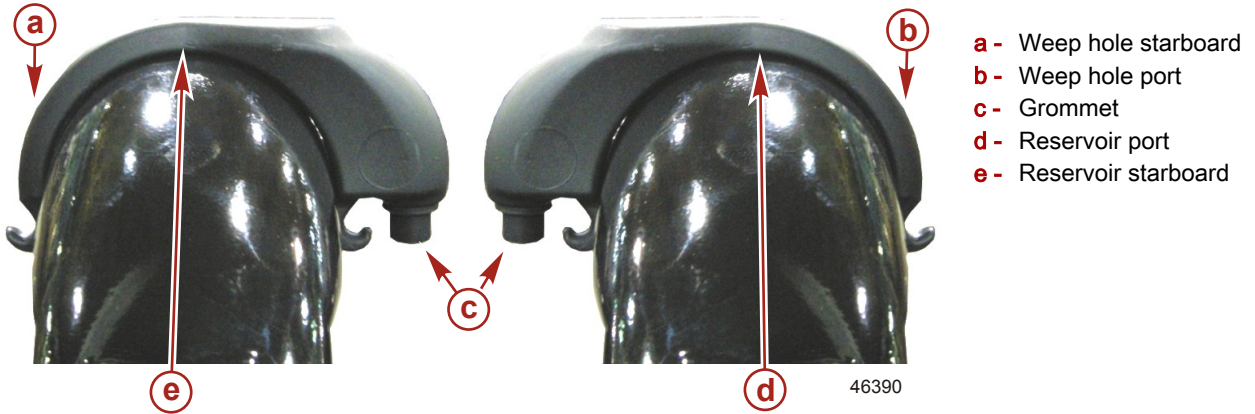

- Place the center hole of the rubber strap over the water fitting on the exhaust elbow and stretch the strap around the bottom side of the exhaust elbow and attach it to the reservoir hooks.

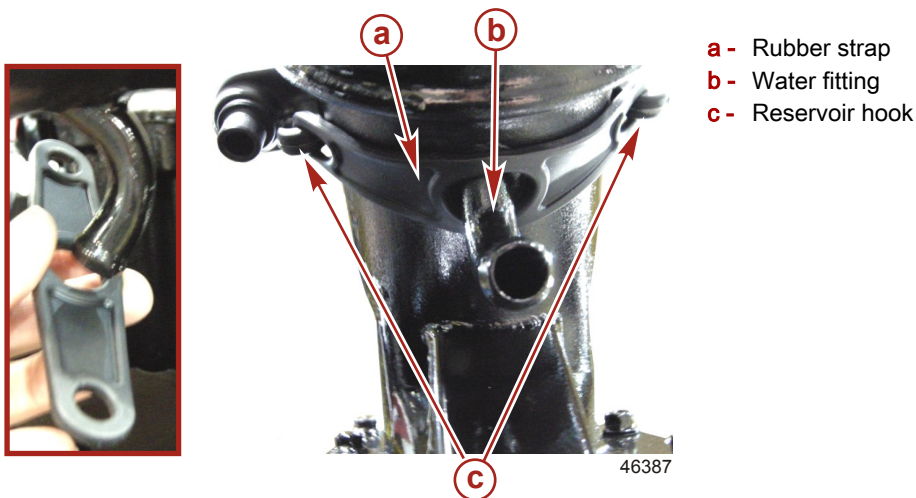

- Insert the duckbill valve fitting into the grommet until the valve is seated against the grommet.
- With a hose clamp on the hose assembly, push the hose end of the vent assembly over the water fitting on the exhaust elbow. Position the T-fitting to face inboard at 45° toward the base of the elbow.
- Install the stay strap over the grommet at the duckbill valve fitting.

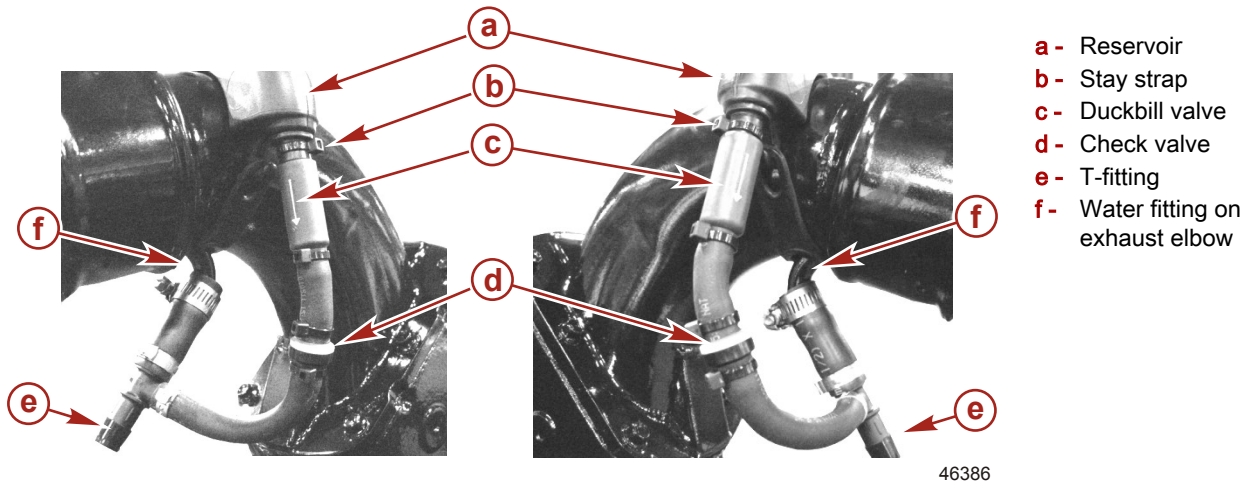

THE INFORMATION IN THIS DOCUMENT IS CONFIDENTIAL AND PROTECTED BY COPYRIGHT AND IS THE PROPERTY OF MERCURY MARINE.

This document is provided for the sole and exclusive use of the original recipient as prescribed by Mercury Marine and may not be distributed or copied, digitally or otherwise, without the prior written consent of Mercury Marine.

- Inspect the grommet-to-reservoir area to assure there is no side-load pulling on the grommet. The grommet should be relaxed and fully seated against the reservoir. The hose should not be bent or kinked. Position the T-fitting portion of the assembly as necessary to ensure proper assembly.

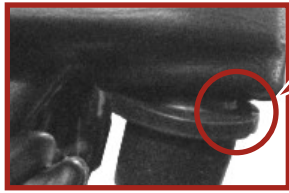

- a - Incorrect assembly
- b - Correct assembly

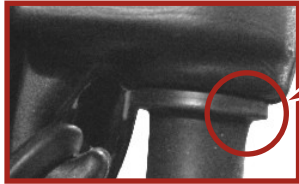

46444

- With the hose clamp on the bypass hose, insert the T-fitting into the bypass hose.
- Tighten the worm-gear hose clamp to specification at the T-fitting and the water fitting on the exhaust elbow.

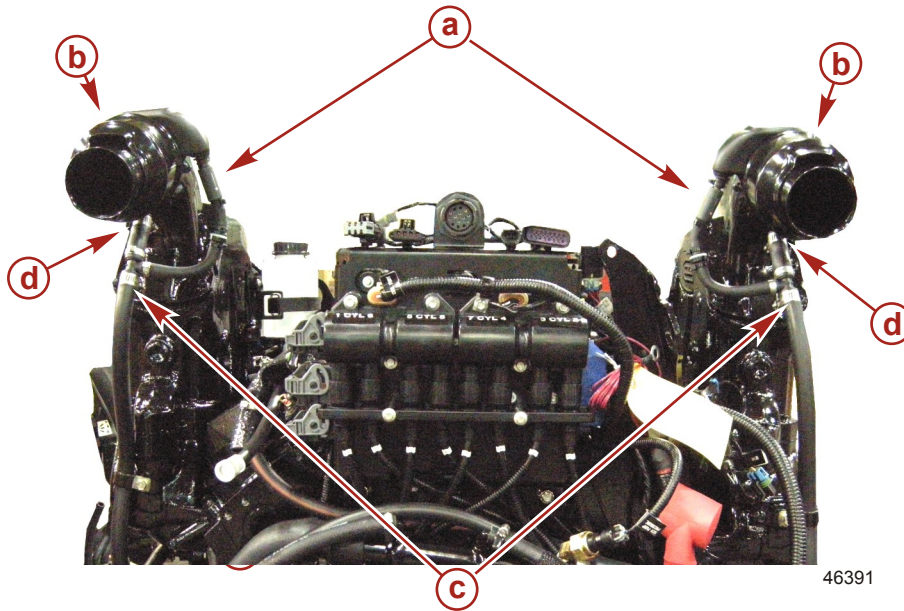

- a - Duckbill valve
- b - Reservoir weep hole
- c - Worm-gear hose clamp at T-fitting
- d - Worm-gear hose clamp at the water fitting

46391

Description	Nm	lb-in.	lb-ft
Worm-gear hose clamp	4	35	-

- Install the cover on the end of the hose clamp.

## Inspecting the Oxygen Sensor Connectors

Sterndrive Models	Serial Number
8.2 MAG ECT	1A350340 – 1A352424
8.2 MAG H.O. ECT	
SeaCore 8.2 MAG ECT	
SeaCore 8.2 MAG H.O. ECT	

THE INFORMATION IN THIS DOCUMENT IS CONFIDENTIAL AND PROTECTED BY COPYRIGHT AND IS THE PROPERTY OF MERCURY MARINE.

This document is provided for the sole and exclusive use of the original recipient as prescribed by Mercury Marine and may not be distributed or copied, digitally or otherwise, without the prior written consent of Mercury Marine.



**IMPORTANT:** If light to moderate corrosion is present on any engine harness connector or sensor, and cannot be removed with the cleaning process. Replace the sensor or wiring harness as needed.

1. Disconnect two post and two pre-exhaust oxygen sensors from the engine wiring harness, being careful not to damage the locking tabs.

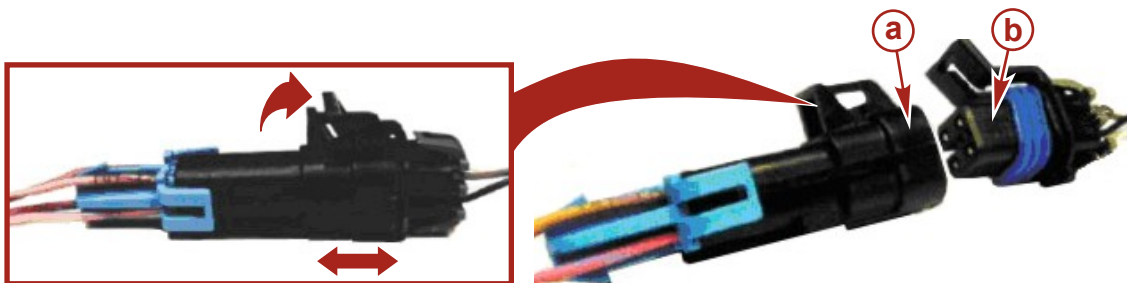

47850

**Pre-exhaust and post-exhaust oxygen sensor**

- a -** Engine harness connector (male)
- b -** Oxygen sensor connector (female)

2. Inspect each sensor and engine harness connector for evidence of condensation (moisture), corrosion, or damaged terminals and sockets. See image below.
3. If condensation is present, carefully use low-pressure compressed air to dry out both the male and female connectors.
4. Clean the pins and sockets using rubbing alcohol and a standard Q-tip (obtained locally) and then air dry.
5. Carefully inspect each pin and socket for corrosion or damage.
6. If damage is present, replace the sensor or harness as necessary.
7. If corrosion is present on any sensor pin, replace that oxygen sensor.
8. If light to moderate corrosion is present on any oxygen sensor connector, it can be removed as follows:
  - a. Locate the pink female terminal adapter (J-35616-5) from the CDS Terminal Adapter kit (SPX P/N MM-46523)

Terminal Test Probe Kit	SPX P/N MM- 46523
 <p>7915</p>	Test probes adapt test meter leads to harness connections without damaging harness terminals. May be used with Computer Diagnostic System (CDS).

- b. Using rubbing alcohol, slide the adapter on and off of each male pin until the corrosion has been removed. See image below.

THE INFORMATION IN THIS DOCUMENT IS CONFIDENTIAL AND PROTECTED BY COPYRIGHT AND IS THE PROPERTY OF MERCURY MARINE.

This document is provided for the sole and exclusive use of the original recipient as prescribed by Mercury Marine and may not be distributed or copied, digitally or otherwise, without the prior written consent of Mercury Marine.

- c. When finished cleaning all four pins, dry the connector with low pressure compressed air.

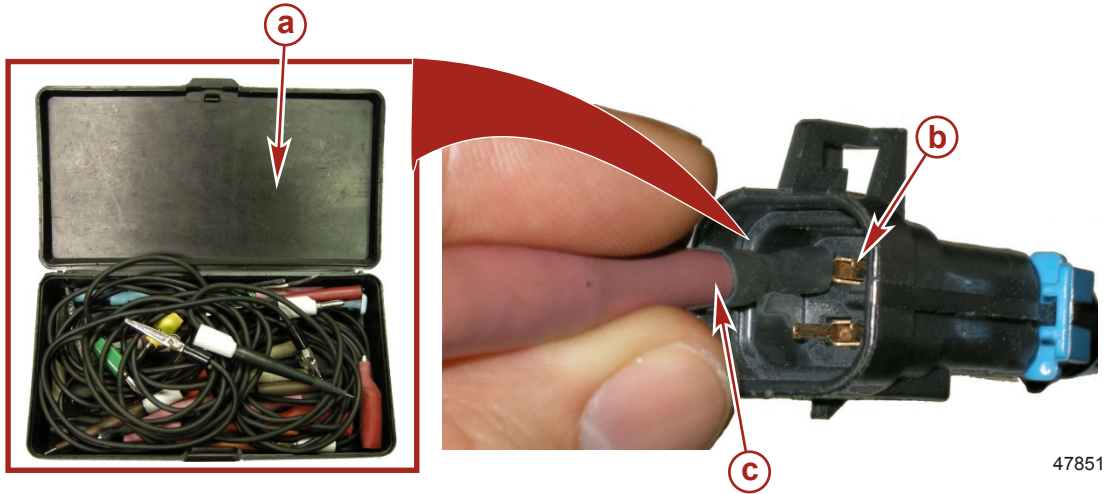

- a - CDS Terminal Adapter kit
- b - Pink female terminal adapter
- c - Male pin (4)

9. Reconnect each oxygen sensor to the engine harness as you complete the inspection/cleaning process.
10. If the corrosion was not removed during the cleaning process, replace the sensor or wiring harness as needed.
11. Use the CDS-G3 service tool to clear any faults after one of the the following procedure, Replacing the Propulsion Control Module (PCM) or Reflashing the Propulsion Control Module (PCM).

Qty.	Description	Part Number
As needed	Oxygen sensor	8M2003959
One per engine	Mechanical engine harness	8M0045252
One per engine	DTS engine harness	8M0045253

## Replacing the Oxygen Sensor

### ⚠ CAUTION

A hot oxygen sensor can cause burns. Do not touch the sensor without first allowing it to cool. Always allow engine components time to reach a safe temperature before installing or servicing engine or drive components.

1. Disconnect the oxygen sensor from the engine harness.

THE INFORMATION IN THIS DOCUMENT IS CONFIDENTIAL AND PROTECTED BY COPYRIGHT AND IS THE PROPERTY OF MERCURY MARINE.

This document is provided for the sole and exclusive use of the original recipient as prescribed by Mercury Marine and may not be distributed or copied, digitally or otherwise, without the prior written consent of Mercury Marine.

- Loosen the screw securing the oxygen sensor cover to the collector and remove the cover.

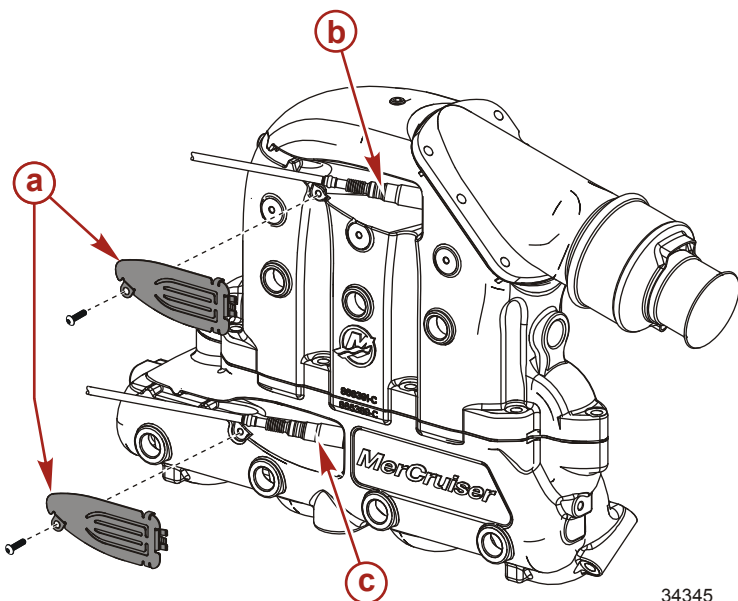

- a - Oxygen sensor cover
- b - Post-catalyst oxygen sensor
- c - Pre-catalyst oxygen sensor

34345

- Remove the oxygen sensors, as needed.

Kent-Moore Oxygen Sensor Socket	KN-46577
<p>32314</p>	<p>Kent-Moore socket (or equivalent 7/8 in. automotive oxygen sensor socket) Aids in the removal and installation of oxygen sensors on products equipped with Emissions Control.</p>

- Use the oxygen sensor tool to install the oxygen sensor. Tighten the sensor to specification.

Description	Nm	lb-in.	lb-ft
Oxygen sensor	50	-	37

- Install the oxygen sensor cover so it is flush against the collector. Tighten the screw to specification.

Description	Nm	lb-in.	lb-ft
Oxygen sensor cover screw	3.5	31	-

- Connect the oxygen sensor connector to the engine harness.

## Inspecting the Spark Plug Wires

Sterndrive Models	Serial Number
8.2 MAG ECT	1A350340-1A352325
8.2 MAG H.O. ECT	
SeaCore 8.2 MAG ECT	
SeaCore 8.2 MAG H.O. ECT	

- Inspect the starboard side spark plug wires making sure clearance exists between the bottom rear corner of the exhaust manifold and spark plug wires.

THE INFORMATION IN THIS DOCUMENT IS CONFIDENTIAL AND PROTECTED BY COPYRIGHT AND IS THE PROPERTY OF MERCURY MARINE.

This document is provided for the sole and exclusive use of the original recipient as prescribed by Mercury Marine and may not be distributed or copied, digitally or otherwise, without the prior written consent of Mercury Marine.

2. If the spark plug wires contact the exhaust manifold, remove and inspect each wire for damage and replace as necessary.

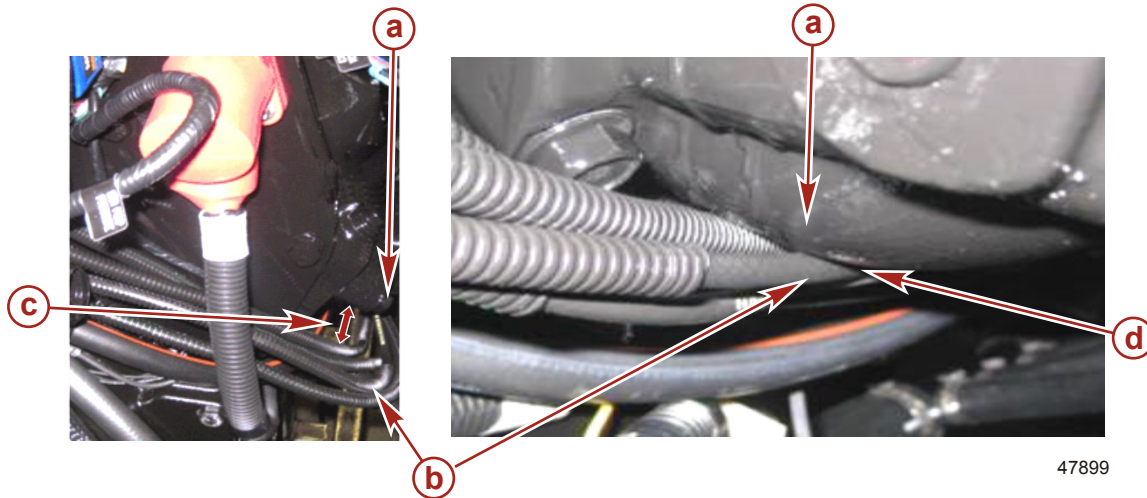

47899

**Spark plug wires correct clearance**

**Spark plug wires incorrect clearance**

- a** - Exhaust manifold
- b** - Spark plug wires
- c** - Clearance
- d** - No clearance

Qty.	Description	Part Number
One per engine	Spark plug wire set	899329A09

3. Route the spark plug wires to ensure an air gap exist between the exhaust manifold and wires.  
**IMPORTANT: The spark plug wires must have clearance from the exhaust manifold to prevent heat damage.**

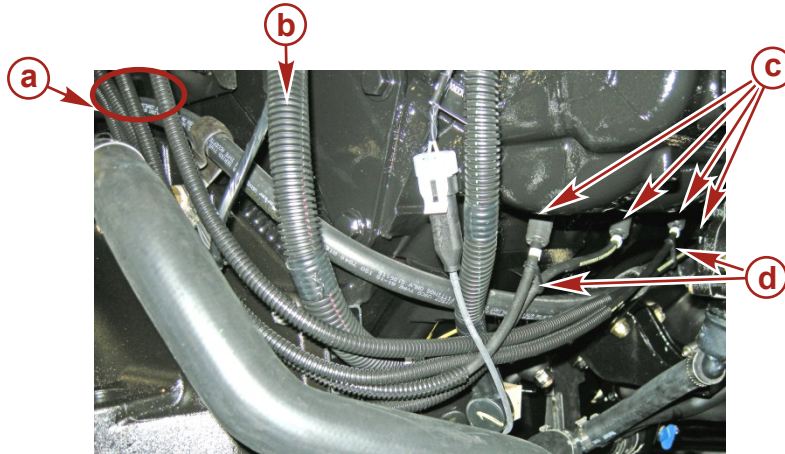

47898

**Spark plug wires typical routing**

- a** - Spark plug wires to coil
- b** - Hot stud assembly
- c** - Spark plug wires
- d** - Clips

THE INFORMATION IN THIS DOCUMENT IS CONFIDENTIAL AND PROTECTED BY COPYRIGHT AND IS THE PROPERTY OF MERCURY MARINE.

This document is provided for the sole and exclusive use of the original recipient as prescribed by Mercury Marine and may not be distributed or copied, digitally or otherwise, without the prior written consent of Mercury Marine.

## Reposition and Torque the Flame Arrestor Clamp

Sterndrive Models	Serial Number
8.2 MAG ECT (DTS only)	1A350340–1A351493
8.2 MAG H.O. ECT (DTS only)	
SeaCore 8.2 MAG ECT (DTS only)	
SeaCore 8.2 MAG H.O. ECT (DTS only)	

- Loosen the hose clamp on the flame arrestor.
- Move the hose clamp to an easily accessible position as shown.
- Hold the flame arrestor in position on the throttle body with the hose clamp completely around the flame arrestor and throttle body.
- Tighten the hose clamp to specification.

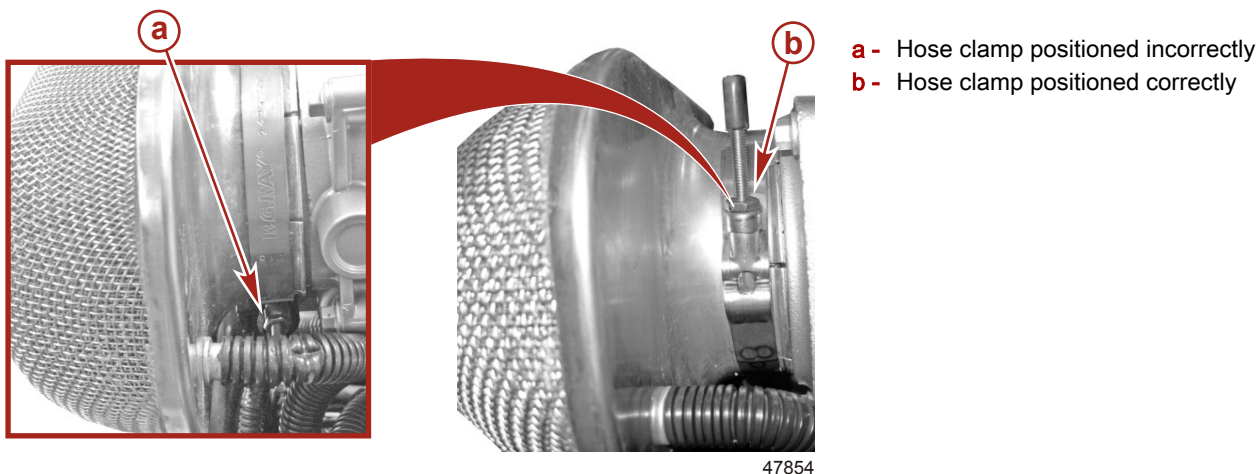

Description	Nm	lb-in.	lb-ft
Flame arrestor hose clamp	6	55	–

## Replacing the Propulsion Control Module (PCM)

**IMPORTANT:** Replace the Propulsion Control Module (PCM) in this serial number range and modules with serial numbers starting in 902 or 903.

Sterndrive Models	Serial Number
8.2 MAG ECT	1A350340 – 1A351701
8.2 MAG H.O. ECT	
SeaCore 8.2 MAG ECT	
SeaCore 8.2 MAG H.O. ECT	

Qty.	Description	Part Number
One per engine	PCM for 8.2 BRAVO ECT	8M0059116
	PCM for 8.2 H.O. BRAVO ECT	8M0059117
	PCM for 8.2 BRAVO ECT DTS	8M0059118
	PCM for 8.2 H.O. BRAVO ECT DTS	8M0059119

**IMPORTANT:** The PCM is a sensitive electrical device, subject to electrostatic damage. Do not touch the connector pins when removing or installing the module.

THE INFORMATION IN THIS DOCUMENT IS CONFIDENTIAL AND PROTECTED BY COPYRIGHT AND IS THE PROPERTY OF MERCURY MARINE.

This document is provided for the sole and exclusive use of the original recipient as prescribed by Mercury Marine and may not be distributed or copied, digitally or otherwise, without the prior written consent of Mercury Marine.

**NOTE:** Return any PCM removed from the engine to the Mercury MerCruiser warranty department.

## Removal

1. Slide the fuse connector up and remove it from its mount on the electrical bracket.

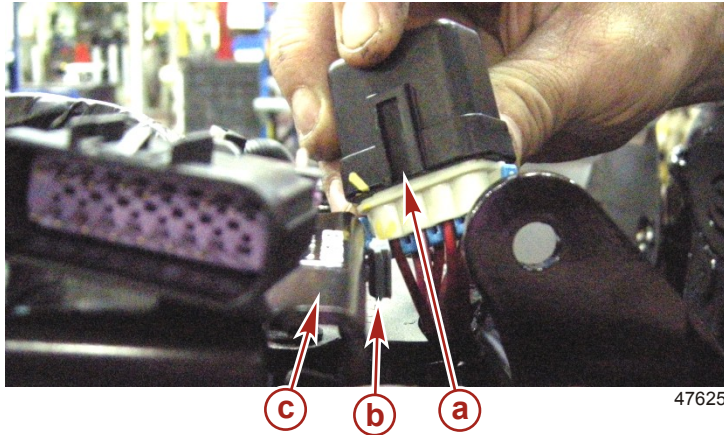

- a** - Fuse connector
- b** - Fuse connector mount
- c** - Electrical bracket

2. Remove the top electrical connector from the PCM. Depress the locking tab and rotate the grey locking lever upward until the electrical connector is disconnected from the PCM. Repeat steps to remove the middle, then the bottom electrical connector.

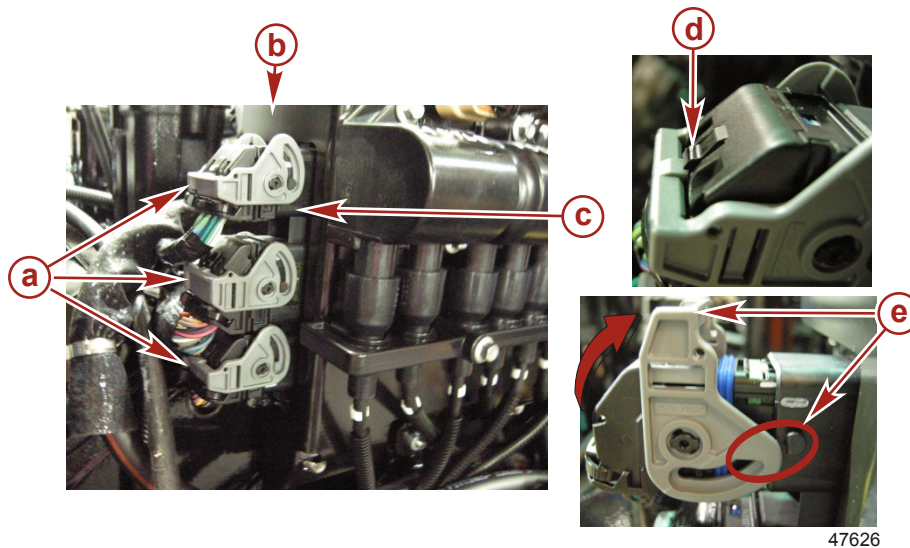

- a** - Electrical connectors in locked position
- b** - Electrical bracket
- c** - PCM
- d** - Locking tab
- e** - Electrical connector unlocked

3. Remove and retain the nuts and washers from the electrical bracket (on the flywheel side of the engine).

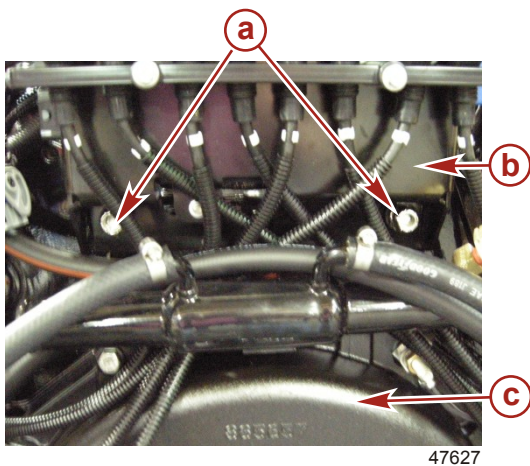

- a** - Nut and washer
- b** - Electrical bracket
- c** - Engine flywheel housing

THE INFORMATION IN THIS DOCUMENT IS CONFIDENTIAL AND PROTECTED BY COPYRIGHT AND IS THE PROPERTY OF MERCURY MARINE.

This document is provided for the sole and exclusive use of the original recipient as prescribed by Mercury Marine and may not be distributed or copied, digitally or otherwise, without the prior written consent of Mercury Marine.

4. Slide the electrical bracket away from engine to gain access to the PCM fasteners.
5. Remove and retain the top screws with washers and slightly loosen the bottom screw holding the PCM to the bracket. The PCM screw holes are slotted for easy removal

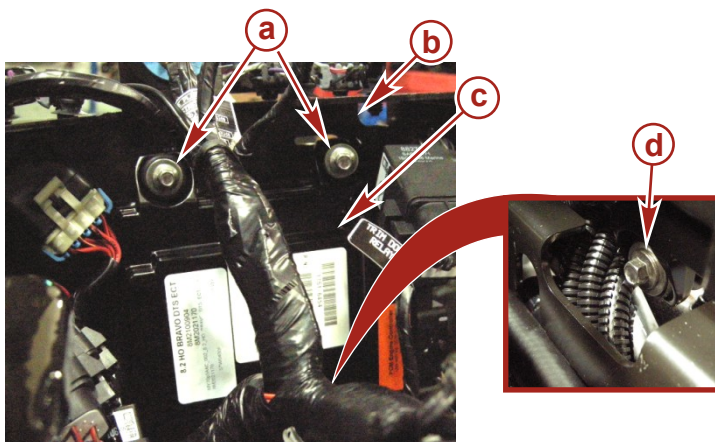

- a - Top screw and washer
- b - Electrical bracket
- c - PCM
- d - Bottom screw and washer

47629

6. Lift the PCM from the bracket.
7. Return the PCM to Mercury MerCruiser warranty department.

### Cleaning and Inspection

1. Clean the exterior of the PCM with a dry cloth, being careful to avoid contact with connector pins.
2. Inspect the outer surfaces for any obvious damage.
3. Visually inspect the electrical pins on the PCM for straightness and corrosion.
4. Visually inspect the connectors on the wiring harness for corrosion and terminals that may have loose connections.

**NOTE:** The PCM is a sealed electrical component. Do not use a damaged PCM.

### Installation

1. Lower the PCM onto the bracket bottom screw and secure it to the bracket using the screws previously removed.
2. Tighten the PCM screws to specification.

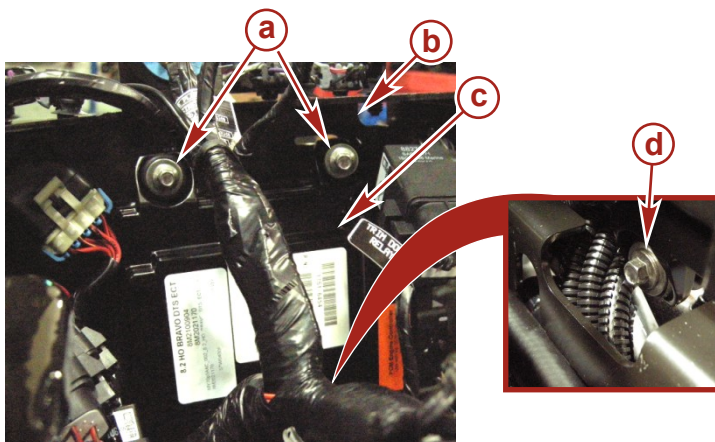

- a - Top screw
- b - Electrical bracket
- c - PCM
- d - Bottom screw

47629

Description	Nm	lb-in.	lb-ft
Screws, PCM to electrical bracket	6	40	-

3. Push the electrical bracket all the way back on the studs and secure it with the washers and nuts previously removed.

THE INFORMATION IN THIS DOCUMENT IS CONFIDENTIAL AND PROTECTED BY COPYRIGHT AND IS THE PROPERTY OF MERCURY MARINE.

This document is provided for the sole and exclusive use of the original recipient as prescribed by Mercury Marine and may not be distributed or copied, digitally or otherwise, without the prior written consent of Mercury Marine.

4. Tighten the nuts to specification.

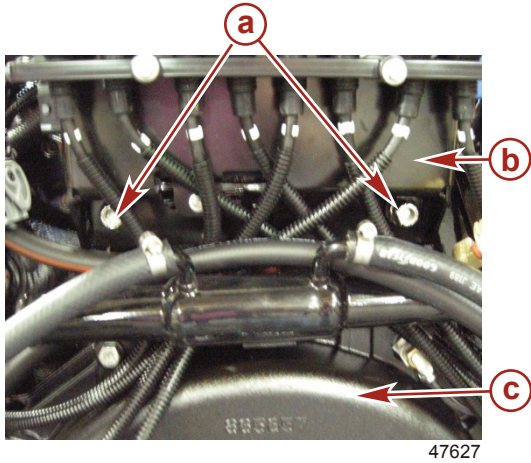

- a** - Nut and washer
- b** - Electrical bracket
- c** - Engine flywheel housing

47627

Description	Nm	lb-in.	lb-ft
Nut, electrical bracket to engine	54	-	40

5. Install the electrical connectors to the PCM in the opposite order as removed. Use the color codes to match the connections and ensure the grey locking levers are completely locked with the locking tabs up.

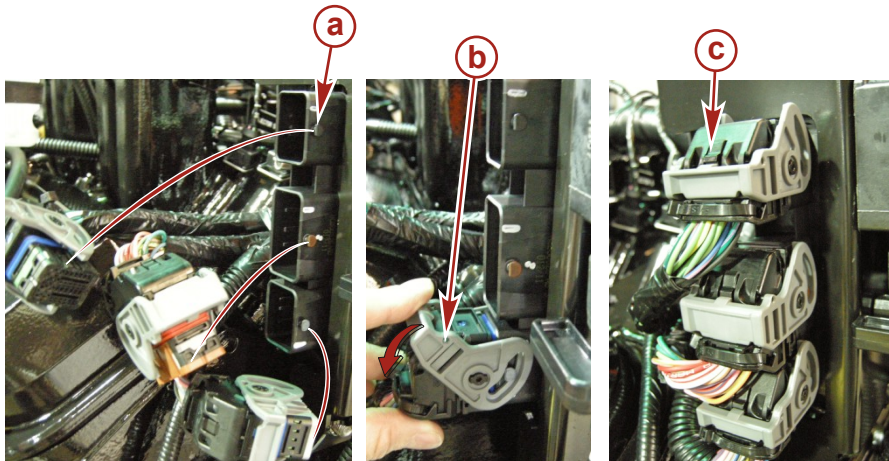

- a** - Matching color codes
- b** - Locking lever
- c** - Locking tabs up

47906

6. Slide the fuse connector in its mount on the electrical bracket.

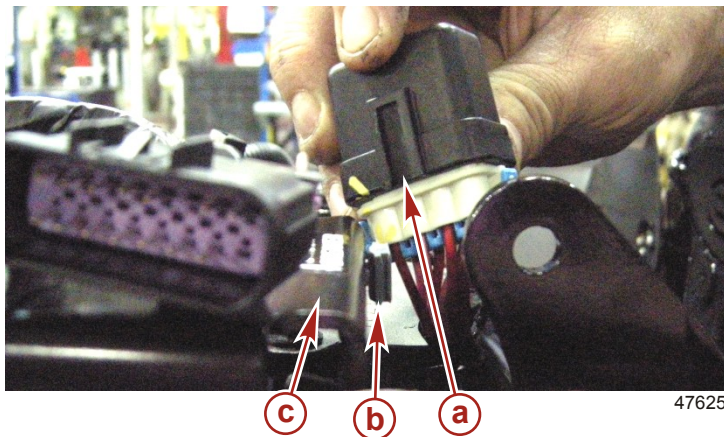

- a** - Fuse connector
- b** - Fuse connector mount
- c** - Electrical bracket

47625

THE INFORMATION IN THIS DOCUMENT IS CONFIDENTIAL AND PROTECTED BY COPYRIGHT AND IS THE PROPERTY OF MERCURY MARINE.

This document is provided for the sole and exclusive use of the original recipient as prescribed by Mercury Marine and may not be distributed or copied, digitally or otherwise, without the prior written consent of Mercury Marine.





## Reflashing the Propulsion Control Module (PCM)

Sterndrive Models	Serial Number
8.2 MAG ECT	1A351702–1A352732
8.2 MAG H.O. ECT	
SeaCore 8.2 MAG ECT	
SeaCore 8.2 MAG H.O. ECT	

## Connecting the Computer Diagnostic System (CDS G3) Service Tool

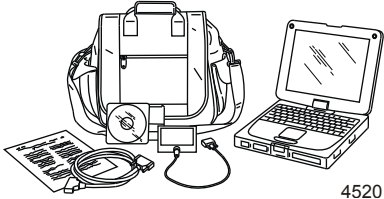
**NOTE:** The Computer Diagnostic System (CDS G3) procedural information is available in the help menu. If you have the CDS hardware, order the software and cable 8M0046124 from Mercury.

Computer Diagnostic System (CDS)	Order through SPX
 <p>4520</p>	<p>Monitors all electrical systems for proper function, diagnostics, and calibration purposes. For additional information, pricing, or to order the Computer Diagnostic System contact:                      SPX Corporation                      28635 Mound Rd.                      Warren, MI 48092                      or call:                      USA - 1-800-345-2233                      Canada - 800-345-2233                      Europe - 49 6182 959 149                      Australia - (03) 9544-6222</p>
<p>CDS G3 Diagnostic Interface Tool With Harness</p>  <p>41993</p>	<p>8M0046124</p> <p>Provides diagnostic support for the Computer Diagnostic System.</p>

## Models Equipped With a SmartCraft Diagnostic Port

1. Ensure all engine key switches and engines are off.
2. Locate the SmartCraft diagnostic port at the boat helm.

**NOTE:** The diagnostic port may not be mounted on the dashboard if space is limited, but may be mounted under the dashboard, or in the cabin at an inconspicuous, but accessible location.

THE INFORMATION IN THIS DOCUMENT IS CONFIDENTIAL AND PROTECTED BY COPYRIGHT AND IS THE PROPERTY OF MERCURY MARINE.

This document is provided for the sole and exclusive use of the original recipient as prescribed by Mercury Marine and may not be distributed or copied, digitally or otherwise, without the prior written consent of Mercury Marine.

3. Remove the cover and insert the CDS G3 interface harness connection.



47772

SmartCraft diagnostic port

4. Connect the CDS G3 interface USB port connector to the USB port on the G3 service tool.

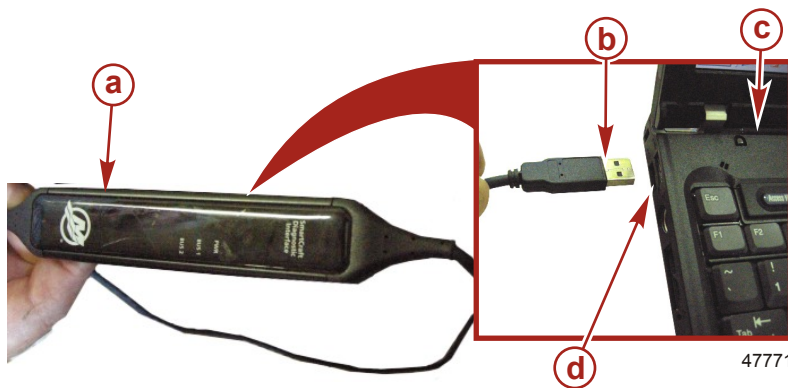

- a - CDS G3 interface tool
- b - CDS G3 interface USB port connector
- c - CDS G3 service tool
- d - USB port on the CDS G3 service tool

47771

### Models Equipped With a SmartCraft Junction Box

1. Ensure all engine key switches and engines are off.
2. Locate the standard junction box under the boat helm and connect the CDS G3 interface harness.

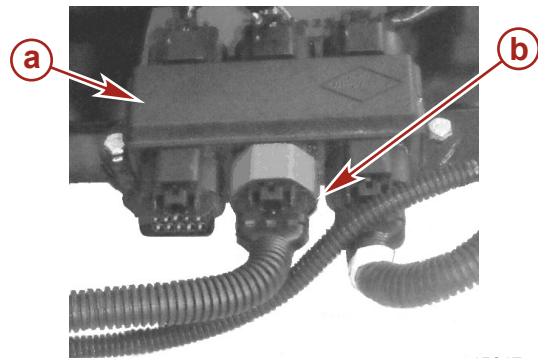

- a - Junction box
- b - CDS G3 interface harness connector

45647

THE INFORMATION IN THIS DOCUMENT IS CONFIDENTIAL AND PROTECTED BY COPYRIGHT AND IS THE PROPERTY OF MERCURY MARINE.

This document is provided for the sole and exclusive use of the original recipient as prescribed by Mercury Marine and may not be distributed or copied, digitally or otherwise, without the prior written consent of Mercury Marine.

- Connect the CDS G3 interface USB port connector to the USB port on the CDS G3 service tool.

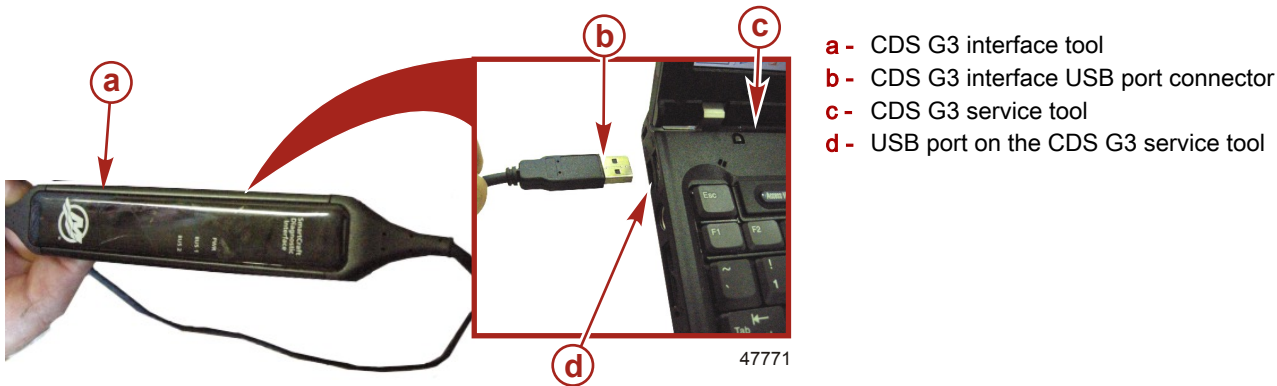

- a - CDS G3 interface tool
- b - CDS G3 interface USB port connector
- c - CDS G3 service tool
- d - USB port on the CDS G3 service tool

**Models Not Equipped With SmartCraft Diagnostic Port or Junction Box**

**IMPORTANT:** The CDS G3 termination harness is a terminal resistor. Only use it when connecting to the engine harness terminator connection. Do not connect the termination harness to the junction box or diagnostic port at the helm.



CDS G3 termination harness

CDS G3 Termination Harness	84-8M0045065
 43351	Contains termination resistors to allow communication when G3 is connected to the engine's diagnostic connector.

- Ensure all engine key switches and engines are off.
- Locate the yellow or red terminator resistor on the engine harness and remove it by pushing the tab in while pulling the connections apart. Retain the yellow or red terminator resistor to reinstall after using the service tool.

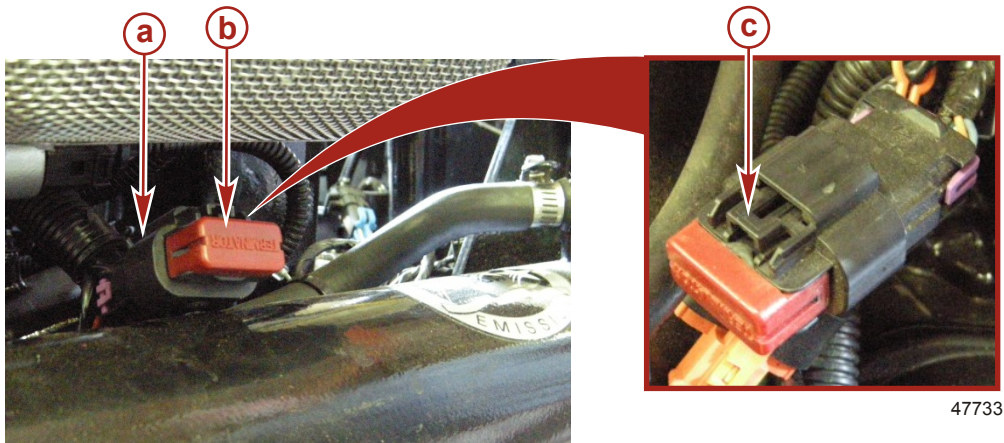

**Terminator resistor (red or yellow)**

- a - Terminator connection
- b - Terminator resistor (red or yellow)
- c - Tab

THE INFORMATION IN THIS DOCUMENT IS CONFIDENTIAL AND PROTECTED BY COPYRIGHT AND IS THE PROPERTY OF MERCURY MARINE.

This document is provided for the sole and exclusive use of the original recipient as prescribed by Mercury Marine and may not be distributed or copied, digitally or otherwise, without the prior written consent of Mercury Marine.

3. Connect the CDS G3 termination harness to the terminator connection on the engine.

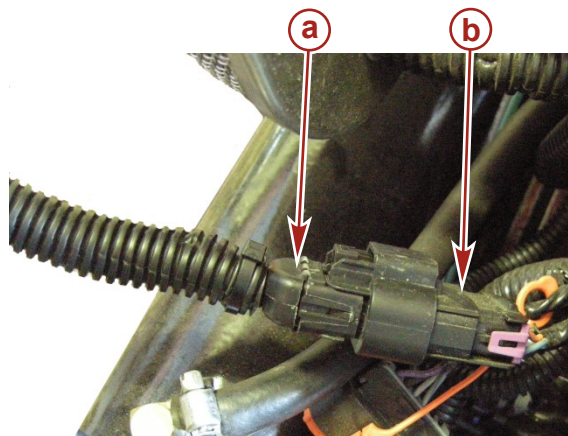

- a - CDS G3 termination harness
- b - Terminator connection

47734

4. Connect the CDS G3 termination harness connector to the CDS G3 interface harness connector.
5. Connect the CDS G3 interface USB connector to the USB port on the CDS G3 service tool.

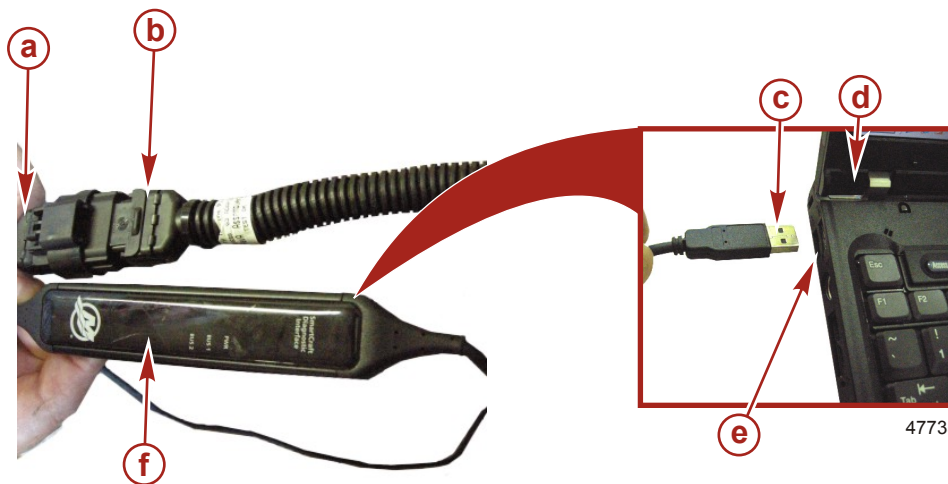

- a - CDS G3 interface harness connector
- b - CDS G3 termination harness connector
- c - CDS G3 interface USB connector
- d - CDS G3 service tool
- e - USB port on the CDS G3 service tool
- f - CDS G3 interface tool

47735

## Refashing

**IMPORTANT:** The hull ID and engine serial numbers are required for updating the PCM software—have them available before reflashing begins.

**IMPORTANT:** The VesselView must be disconnected from the Smart J-box Starboard SmartCraft Display 10-pin connection and the Smart J-box multi-ignition 8-pin connection before starting the PCM reflash.

**IMPORTANT:** If this is a twin or multiple engine application, reflash each engine separately. Keep other engine key switches in the off position.

**NOTE:** Reflashing the starboard outer city ID 11 engine first is preferred on twin or multiple engine applications.

1. Locate and write down the hull ID and engine serial number to enter when requested.
2. Disconnect the SmartCraft gauges or VesselView.
3. Turn the key switch (of the engine you are reflashing) to the "on" position.
4. Turn on the CDS G3.
  - a. Verify the software for CDS G3 is at level 1.2.33 and above.
  - b. Verify the CAN P icon is green, indicating communications with the PCM controller.

THE INFORMATION IN THIS DOCUMENT IS CONFIDENTIAL AND PROTECTED BY COPYRIGHT AND IS THE PROPERTY OF MERCURY MARINE.

This document is provided for the sole and exclusive use of the original recipient as prescribed by Mercury Marine and may not be distributed or copied, digitally or otherwise, without the prior written consent of Mercury Marine.

- c. If CAN P and CAN H are both yellow, the PCM controller is not communicating. Find and correct the connection problem.

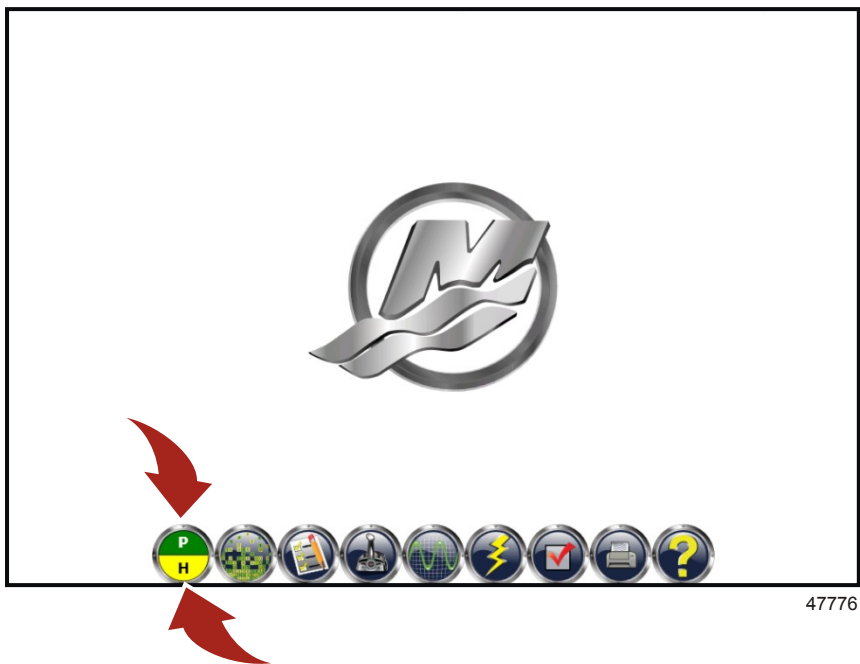

- 5. Wait for the Module Data screen to appear.  
**NOTE:** The selections in the Module Data screen are greyed-out because the eBOM has not been selected.
- 6. Select the eBOM icon.

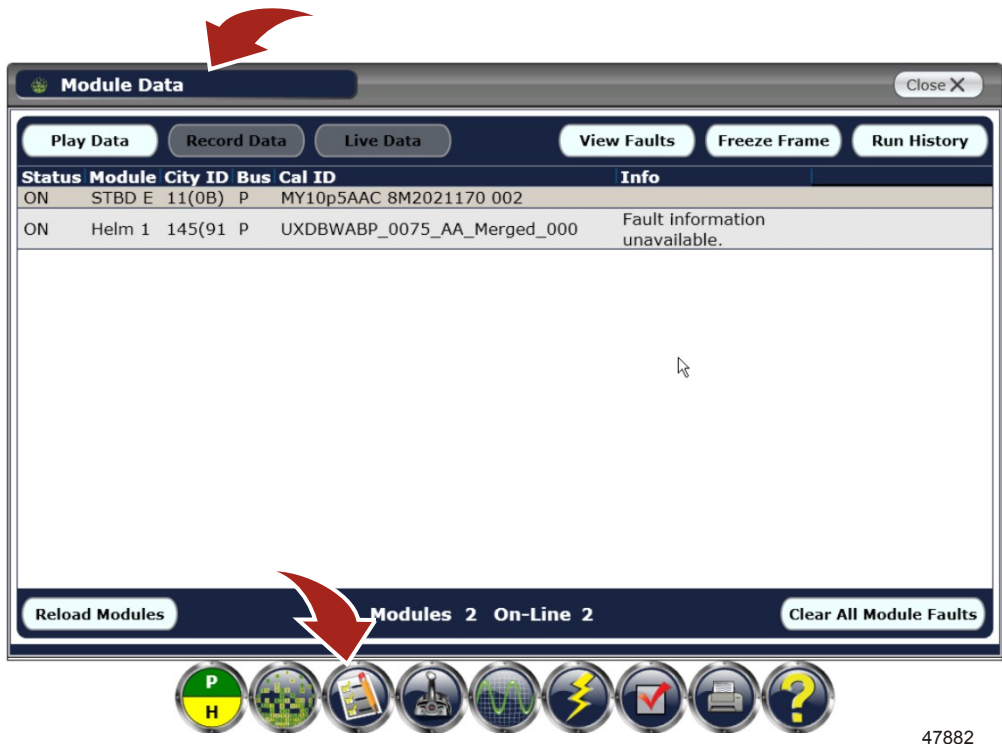

- 7. Locate the engine package listed on this screen and click on its Select button.
  - a. Click on the Close X button.
  - b. Select Module Data icon.

THE INFORMATION IN THIS DOCUMENT IS CONFIDENTIAL AND PROTECTED BY COPYRIGHT AND IS THE PROPERTY OF MERCURY MARINE.

This document is provided for the sole and exclusive use of the original recipient as prescribed by Mercury Marine and may not be distributed or copied, digitally or otherwise, without the prior written consent of Mercury Marine.

- c. Click on the Live Data button.

The screenshot shows the 'eBOM' application window titled 'Please Select an eBOM (158)'. It contains a table with the following columns: eBOM, Total, Matches, MisMatches, Not Found, and an action button. The table lists various engine configurations. A red arrow points to the 'Live Data' button (represented by a globe icon) in the bottom toolbar.

eBOM	Total	Matches	MisMatches	Not Found	Action
Single MCM PCM09 DTS non-EC Bravo 1 MY10p5AAC	2	2	0	0	Select
Single MIE PCM09 EC DTS BB or SB MY10p5AAC	2	2	0	0	Select
Single MCM PCM09 DTS EC Bravo MY10p5AAC	2	2	0	0	Deselect
Dual MCM PCM09 DTS non-EC Bravo 1 MY10p5AAC	3	2	0	1	Select
Twin MCM PCM09 EC DTS Bravo MY10p5AAC	4	2	0	2	Select
Single MCM PCM09 DTS non-EC Bravo 2 MY10p5AAC	4	2	0	2	Select
Twin MIE PCM09 EC DTS BB or SB MY10p5AAC	4	2	0	2	Select
Dual MCM PCM09 DTS non-EC Bravo 2 MY10p5AAC	6	2	0	4	Select
Single MCM PCM09 EC Mech SB Alpha MY10p5AAC	1	1	0	0	Select
Single MCM PCM09 EC Mech SB or BB Bravo MY10p5AAC	1	1	0	0	Select
Single MIE PCM09 EC Mech BB or SB MY10p5AAC	1	1	0	0	Select
Single MCM PCM09 EC 3.0L Alpha MY10p5AAC	1	1	0	0	Select
Single MCM PCM09 Mechanical non-EC Bravo 1 MY10p5AAC	1	1	0	0	Select
Single MCM PCM09 DTS EC Bravo MY08AAG	2	1	1	0	Select
Single MIE PCM09 EC DTS BB or SB MY08AAE	2	1	1	0	Select
Single MCM PCM09 DTS EC Bravo MY08AAE	2	1	1	0	Select

**IMPORTANT:** Reflashing a PCM with serial numbers starting in 904 updates the mechanical and DTS engine packages. Reflashing a PCM with serial numbers starting in 905 updates the mechanical engine packages only.

**NOTE:** If you find a PCM with serial numbers starting in 902 or 903 listed in the City ID. Do not attempt to reflash. Replace the PCM.

- 8. Locate the PCM serial number and Cal ID.
  - a. Under the Values column write down the Cal ID and Serial Number for later use.

THE INFORMATION IN THIS DOCUMENT IS CONFIDENTIAL AND PROTECTED BY COPYRIGHT AND IS THE PROPERTY OF MERCURY MARINE.

This document is provided for the sole and exclusive use of the original recipient as prescribed by Mercury Marine and may not be distributed or copied, digitally or otherwise, without the prior written consent of Mercury Marine.

- b. Click on the Close X button.

Name	Values	Units	Description
J1939_Cal_ID	8M2021170		Calibration ID
SwRevisionTxt	MY10p5AAC_002_502_DTS_P0904_P		Software Version
SwIdTxt	MY10p5AAC		Software ID
SerialNumber	904HY3YSI1A003TH		PCM Serial Number
CurrentEngineLocation	Stbd		PCM Engine Location
RunTime	0.25	min	Total Engine Run Time
EngineSpeed	0	RPM	Engine Speed
DesiredIdleSpeed	0	RPM	Desired Idle Speed
BattVolt	12.93	V	Battery
SysVolt	13.35	V	System
XDRPa	5.01	V	Power 1 (Engine Sensors)
XDRPb	5.02	V	Power 2 (SmartCraft Sensors)
BARO	14.2	psi	Barometric Pressure (Baro)
MAP_Angle	14.23	psi	Manifold Pressure (MAP)
GuardianLatchedPwrLim	100.00	%	Available Power @ PCM
GuardianCause	GC_NONE		Guardian Due to:
DemandLinear	0.00	%	Demand
Arb_TPS	8.88	%	Throttle Position
TPS1_ADC	174	ADC	TPS 1 - ADC
TPS2_ADC	180	ADC	TPS 2 - ADC
LoadPercent	7.80	%	Load
BaseSparkAdv	2.0	°	Spark Advance
KnkSpkAdv	0.0,0.0,0.0,0.0,0.0,0.0,0.0,0.0	°	Knock Retard
Engine_PercentMisfire	0.00	%	Engine Misfire
CylMisfire_CountArr	0.0,0.0,0.0,0.0	Count	Cylinder Misfire (in firing order)

47887

Replace any PCM with serial numbers starting in 902 or 903

- 9. Select the Help (question mark) icon.
  - a. In the bookmark on the left, click + next to Reflash to get drop down menu.
  - b. Select the MerCruiser Reflash Reference.

47888

- 10. In this spread sheet select the package Cal ID number you previously recorded.

THE INFORMATION IN THIS DOCUMENT IS CONFIDENTIAL AND PROTECTED BY COPYRIGHT AND IS THE PROPERTY OF MERCURY MARINE.

This document is provided for the sole and exclusive use of the original recipient as prescribed by Mercury Marine and may not be distributed or copied, digitally or otherwise, without the prior written consent of Mercury Marine.

- a. Click on the X to close the spread sheet.
- b. Select Module Reflash (lightning bolt) icon.

**MerCruiser Reflash Reference**

Model Description	Calibration in the PCM	Is this calibration the latest available	G3 Reflash Package Call is latest Reflash Replace PCM	Part Number to Order Replacement PCM	PRODUCT LINE	CONTROL TYPE
3.0L ALPHA ECT FWC	8M2005277	NO	8M2020693	8M0049841	MCM	1-MECH
3.0L ALPHA ECT FWC	8M2014915	NO	8M2020693	8M0049841	MCM	1-MECH
3.0L ALPHA ECT FWC	8M2017075	NO	8M2020693	8M0049841	MCM	1-MECH
3.0L ALPHA ECT FWC	8M2018036	NO	8M2020693	8M0049841	MCM	1-MECH
3.0L ALPHA ECT FWC	8M2019101	NO	8M2020693	8M0049841	MCM	1-MECH

47889

11. Click on the Module Reflash button.

**Reflash** [CLOSE]

Module Reflash

History

Reflash

47966

THE INFORMATION IN THIS DOCUMENT IS CONFIDENTIAL AND PROTECTED BY COPYRIGHT AND IS THE PROPERTY OF MERCURY MARINE.

This document is provided for the sole and exclusive use of the original recipient as prescribed by Mercury Marine and may not be distributed or copied, digitally or otherwise, without the prior written consent of Mercury Marine.



12. Type 2011-03 in the Search Text box and press the enter key on your keyboard.

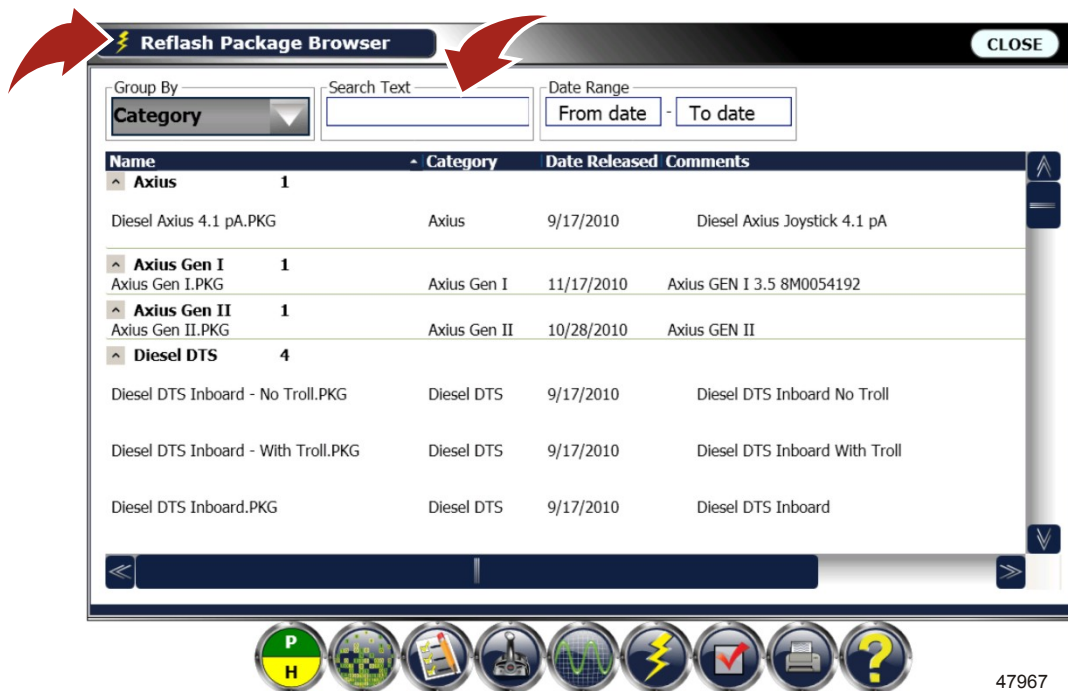

13. Highlight the engine package that you previously selected. Click on the Next button.



14. The Prerequisite Screen will appear, verify all items have green check marks.

**IMPORTANT:** You must have all green check marks on the Prerequisite Screen to continue.

**NOTE:** If this is a twin or multiple engine application, only turn the key switch of the engine you are reflashing to the "on" position. Keep other engine key switches in the "off" position.

- a. If all items are not Green, locate and fix the issue such as verify computer settings, batteries etc to get all green check marks on Prerequisite Screen.

THE INFORMATION IN THIS DOCUMENT IS CONFIDENTIAL AND PROTECTED BY COPYRIGHT AND IS THE PROPERTY OF MERCURY MARINE.

This document is provided for the sole and exclusive use of the original recipient as prescribed by Mercury Marine and may not be distributed or copied, digitally or otherwise, without the prior written consent of Mercury Marine.

b. When all items have the green check marks, click on the Next button.

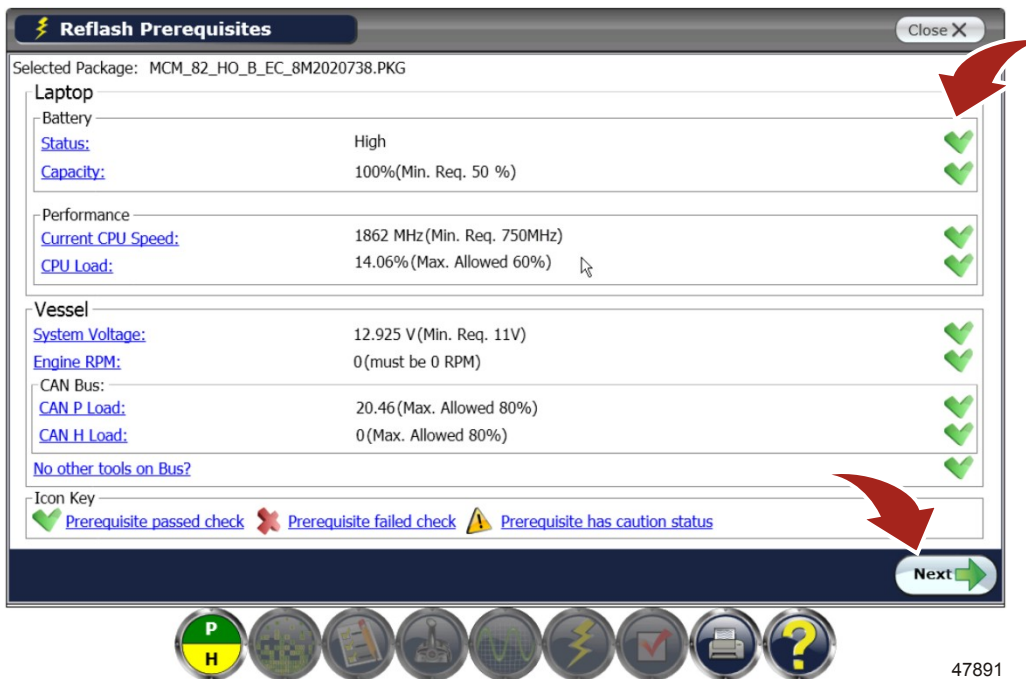

15. Reflash Module View screen shows if an update is available for the engine package. Click on the Next button.



THE INFORMATION IN THIS DOCUMENT IS CONFIDENTIAL AND PROTECTED BY COPYRIGHT AND IS THE PROPERTY OF MERCURY MARINE.

This document is provided for the sole and exclusive use of the original recipient as prescribed by Mercury Marine and may not be distributed or copied, digitally or otherwise, without the prior written consent of Mercury Marine.

16. Enter the Hull ID number and the engine serial number. Click on the Next button.

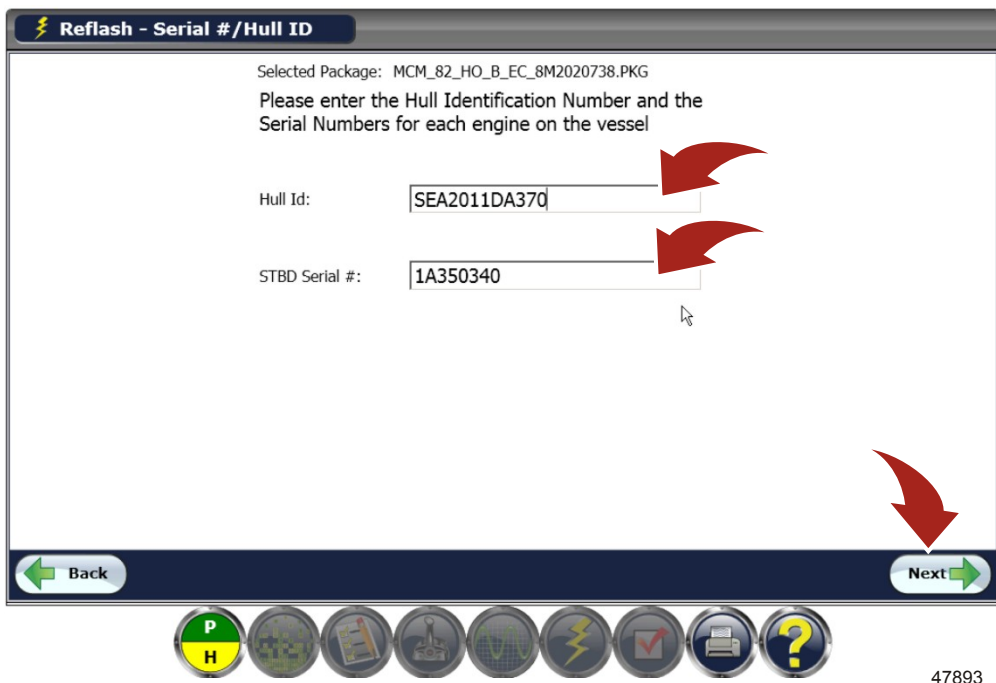

17. Read and follow the instructions on the Reflash Cautions screen.
- IMPORTANT: Failure to abide by the reflash warnings and cautions will result in the PCM being unable to communicate and it will be locked. Contact the Customer Service if this occurs.**
- Check all connections listed.
  - Click on Begin Reflash button.

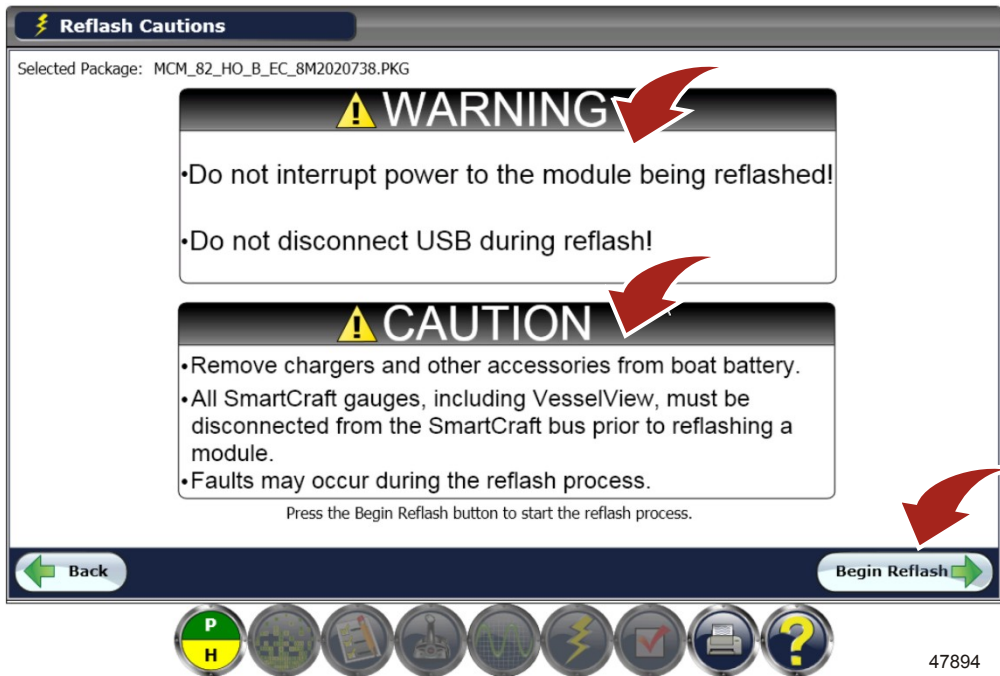

THE INFORMATION IN THIS DOCUMENT IS CONFIDENTIAL AND PROTECTED BY COPYRIGHT AND IS THE PROPERTY OF MERCURY MARINE.  
 This document is provided for the sole and exclusive use of the original recipient as prescribed by Mercury Marine and may not be distributed or copied, digitally or otherwise, without the prior written consent of Mercury Marine.

18. Allow the reflash to run without interruption.

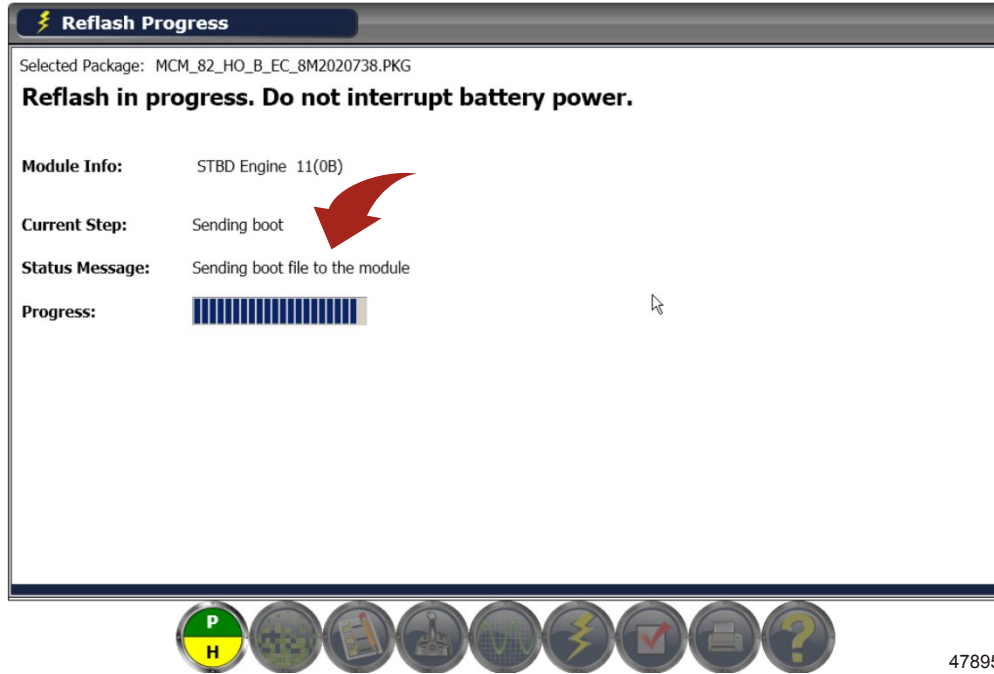

- 19. Watch the Status Message: when it reads Reflash Successful - New Cal ID.....
  - a. Follow the steps in the Post Reflash Comments
  - b. Click on the Next button.

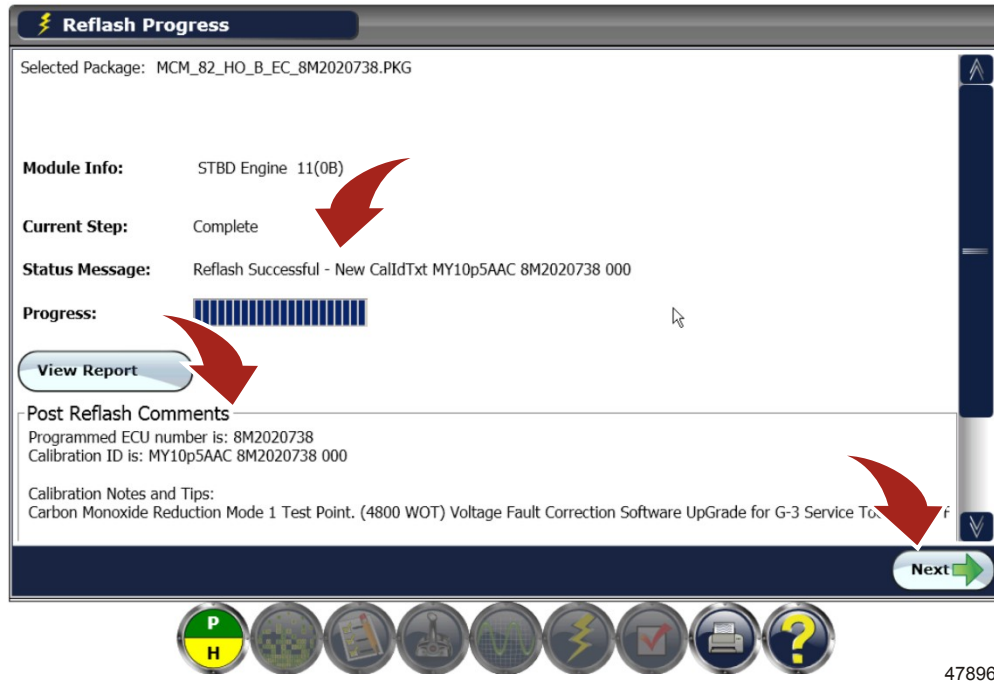

- 20. Follow steps to completion and click the Finish button.
- 21. As an option, you may click the History button to view what you did.
- 22. If this is a twin or multiple-engine application, reset the port engine location.

THE INFORMATION IN THIS DOCUMENT IS CONFIDENTIAL AND PROTECTED BY COPYRIGHT AND IS THE PROPERTY OF MERCURY MARINE.

This document is provided for the sole and exclusive use of the original recipient as prescribed by Mercury Marine and may not be distributed or copied, digitally or otherwise, without the prior written consent of Mercury Marine.

## Starting the Power Package

1. Ensure that all exhaust and electrical connections are connected properly and secure.

### ⚠ CAUTION

**Disconnecting or connecting the battery cables in the incorrect order can cause injury from electrical shock or can damage the electrical system. Always disconnect the negative (-) battery cable first and connect it last.**

2. Connect the battery cables to a fully charged battery. Clean the battery cable clamps and terminals and reconnect cables. Tighten each cable clamp securely.
3. Ensure that all cooling system hoses are connected properly and hose clamps are tight.

### NOTICE

**Without sufficient cooling water, the engine, the water pump, and other components will overheat and suffer damage. Provide a sufficient supply of water to the water inlets during operation.**

4. Provide a sufficient supply of water to the water inlets before starting the engine.
5. Start the engine and closely observe instrumentation to ensure that all systems are functioning correctly.
6. Carefully inspect the engine for fuel, oil, fluid, water, and exhaust leaks.
7. Check for fault codes on the CDS G3 tool.

## Owner Notification

All registered owners within the affected serial number range will receive a letter from Mercury Marine. This letter will explain the situation and request that they contact their local dealer to set up a time to have this inspection performed. A copy of this letter is included with this bulletin.

Some affected power packages will have been updated before shipment. Visit MercNET or contact MerCruiser Customer Service or your regional service center to determine whether repairs have already been completed on a given package. As a Mercury MerCruiser dealer, you should also contact affected customers to make them aware of this recall and to schedule an appointment for the repair.

## Warranty

Mercury Marine will credit the dealer for the cost of the part and the labor. Submit a warranty claim through your normal warranty-processing channel, listing the following information:

- MerCruiser engine serial number
- Flat Rate Code and Labor

Task	Flat Rate Code	Labor (h)
Vent valve installation per side	SB 10	1.0
Elbow inspection only per side	SB 05	0.5
Elbow inspection per side including removal and replacement	MX 14	1.0
O2 sensor connector inspection	SB 02	0.2
O2 sensor connector engine harness side cleaning	SB 02	0.2
O2 sensor removal and replacement	ME 88	0.5
Spark plug wires inspection	SB 01	0.1
Spark plug wire removal and replacement	SB 04	0.4
PCM removal and replacement	MJ 23	1.8
Reposition and torque flame arrestor	MJ17	0.2
PCM reflash	SB05	0.5

- Part Code – 599
- Failure Code – 40

**Outside the United States and Canada:** Follow instructions issued by your local office or by your distributor.

THE INFORMATION IN THIS DOCUMENT IS CONFIDENTIAL AND PROTECTED BY COPYRIGHT AND IS THE PROPERTY OF MERCURY MARINE.

This document is provided for the sole and exclusive use of the original recipient as prescribed by Mercury Marine and may not be distributed or copied, digitally or otherwise, without the prior written consent of Mercury Marine.

## Old Part

- **In the United States and Canada:** Return any exhaust elbow and PCM if removed from the engine, to the Mercury MerCruiser warranty department.
- **Outside the United States and Canada:** Follow instructions issued by your Marine Power International office or by your distributor.

THE INFORMATION IN THIS DOCUMENT IS CONFIDENTIAL AND PROTECTED BY COPYRIGHT AND IS THE PROPERTY OF MERCURY MARINE.

This document is provided for the sole and exclusive use of the original recipient as prescribed by Mercury Marine and may not be distributed or copied, digitally or otherwise, without the prior written consent of Mercury Marine.

Dear Mercury Marine Customer:

Thank you for the purchase of your new boat powered by a Mercury MerCruiser 8.2 Emission Control Sterndrive engine package. We appreciate your business and hope you are enjoying the boat. We are contacting you, however, because we believe that certain upgrades to your engine package will enhance your boat ownership experience. The upgrades will be performed at Mercury's expense.

## **SITUATION**

We have determined that some 8.2 Sterndrive Emission Control engines (which, according to our records, is the engine that powers your boat) may experience hydraulic lock if the engine is run hard and then keyed off quickly. If hydraulic lock occurs, the engine may be prevented from restarting, and could damage internal engine components. Although these occurrences have been rare, we believe it is prudent to address the potential issue with system upgrades to help ensure that you have nothing but positive boating experiences in the future. You may continue to use your boat before you work with your dealer to have these upgrades performed, but you should make repair arrangements as soon as possible. In addition to installing a vent valve to address the hydraulic lock possibility, some engines will benefit from other engine upgrades that we will also make at our expense.

## **WHAT YOU SHOULD DO**

Contact your authorized Mercury MerCruiser dealer and make arrangements for having this vent valve installed. The dealer will refer to Mercury MerCruiser Service Bulletin 2011-03 for instructions. You must deliver your boat to the dealer and present this letter to the dealer. If you are having difficulty obtaining repairs, please contact our Customer Contact Center at 405 743 6566 for assistance or use the dealer locator feature at [www.mercurymarine.com](http://www.mercurymarine.com).

If you have sold the engine or boat, please contact our Registration department at 920 929 5054 or e-mail us at [registration\\_support@mercmarine.com](mailto:registration_support@mercmarine.com) to provide information on the new owner. Please refer to MerCruiser Service Bulletin 2011-03 with your information.

You may operate your engine until this repair has been completed.

## **WHAT WE WILL DO**

We will reimburse the dealer for performing the upgrades in accordance with the instructions outlined in the service bulletin. There will be no cost to you to have this work performed.

We apologize for the inconvenience performing this upgrade will cause you; however, we have taken this action to ensure that your future boating experience will be enjoyable and trouble-free.

Sincerely,

Mercury MerCruiser Service Department