

Circulate to:     Sales Manager     Accounting     Service Manager     Technician     Parts Manager

## Leaking Drain Plug on Gen III Cool Fuel Modules

### Scope

Worldwide.

### Models Affected

MerCruiser engines with Gen III Cool Fuel modules supplied with drain plugs and falling within the following ranges:

Engine Models	Serial Number Range
Small block (5.0, 5.7, 6.2, 350 MAG, 377 MAG)	1A658264 and below
Big block (8.1, 8.2, 496)	1A353805 and below

Engines of each type with serial numbers above the listed range have perfect seal already applied to the blue drain plug.

### Situation

The blue drain plug must be firmly seated in the module housing and Perfect Seal should be applied to its threads. Failure to do so will allow salt water to seep in and damage the plug.

### Solution

Before installing the drain plug in the Gen III Cool Fuel module:

- Make sure that the sealing surfaces are clean and free of salt deposits.
- Verify that the new O-ring on the drain plug is not cut or damaged.
- Verify that the O-ring on the plug is 2.61 mm (0.103 in.) thick. If the O-ring is thinner, replace the O-ring.
- Verify that the drain plug threads are clean and free of deposits. If necessary, replace the plug (part number 806608A02).
- Verify that the threads of the fuel module housing are clean and free of deposits or corrosion. If necessary, clean the threads with a ½-13 tap; then apply sealant to the threads of the housing before installing the drain plug.

Tube Ref No.	Description	Where Used	Part No.
 19	Perfect Seal	Threads of drain plug	92-34227Q02

- Tighten the drain plug until the O-ring makes contact with the module housing; then rotate the drain plug another 180°.

THE INFORMATION IN THIS DOCUMENT IS CONFIDENTIAL AND PROTECTED BY COPYRIGHT AND IS THE PROPERTY OF MERCURY MARINE.

This document is provided for the sole and exclusive use of the original recipient as prescribed by Mercury Marine and may not be distributed or copied, digitally or otherwise, without the prior written consent of Mercury Marine.

## Leaking Drain Plug on Gen III Cool Fuel Modules

If replacing a complete Gen III Cool Fuel system that will be used in salt water, apply Perfect Seal to the threads of the drain plug.

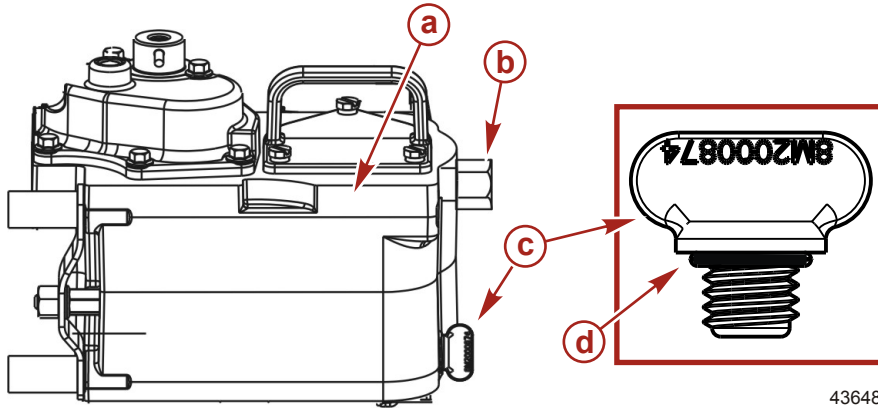

- a - Gen III Cool Fuel module
- b - Fuel inlet fitting
- c - Drain plug
- d - O-ring

43648

THE INFORMATION IN THIS DOCUMENT IS CONFIDENTIAL AND PROTECTED BY COPYRIGHT AND IS THE PROPERTY OF MERCURY MARINE.

This document is provided for the sole and exclusive use of the original recipient as prescribed by Mercury Marine and may not be distributed or copied, digitally or otherwise, without the prior written consent of Mercury Marine.