



Service Bulletin

Bulletin No. 2011-67
CMD 2011-07

Circulate to: Sales Manager Accounting Service Manager Technician Parts Manager

Change to Disassembly Procedure for Zeus Propeller Shaft Bearing Carrier

Models Affected

Zeus HH and IH Model Pod Drives

Situation

The repair procedure for the disassembly of the propeller shaft bearing carrier in Service Manual #45 requires revision. The instructions provided below supersede those printed in Service Manual #45.

Correction

Printed copies of Service Manual #45 should be marked up to refer to this bulletin for disassembly. Follow these instructions:

Propeller Shaft Bearing Carrier Disassembly

The outer propeller shaft seal and needle bearings in the bearing carrier are shown here before disassembly.

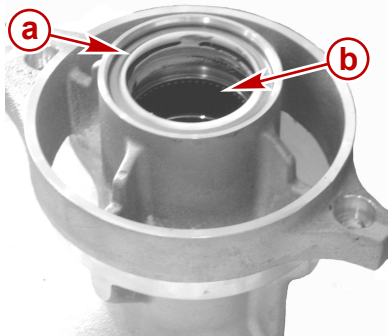

a - Seal
b - Needle bearing

36507

Removing the Outer Propeller Shaft Seal from the Bearing Carrier

NOTE: Perform this procedure if you are replacing only the outer propeller shaft seal. Proceed to **Removing the Outer Propeller Shaft Needle Bearing** if both the seal and the bearing need replacement.

THE INFORMATION IN THIS DOCUMENT IS CONFIDENTIAL AND PROTECTED BY COPYRIGHT AND IS THE PROPERTY OF MERCURY MARINE.

This document is provided for the sole and exclusive use of the original recipient as prescribed by Mercury Marine and may not be distributed or copied, digitally or otherwise, without the prior written consent of Mercury Marine.

1. Insert the seal removal tool through the carrier and into the seal.

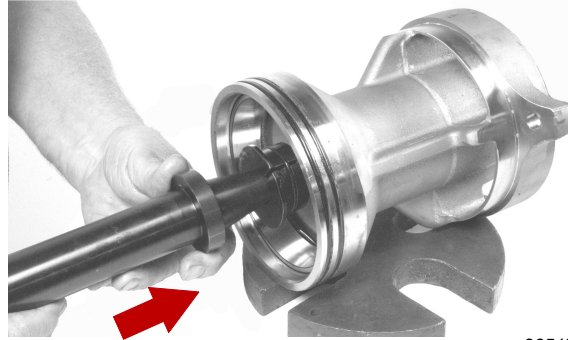

36517

Inserting the seal removal tool

Bearing and Seal Removal Tool	91-862064A 1
 <p>10685</p>	<p>Aids in the removal of the outer propeller shaft needle bearing and oil seals.</p>

2. Expand the collets of the tool to fit into the outer propeller shaft seal, leaving a gap between the collet and bearing carrier housing, as shown.

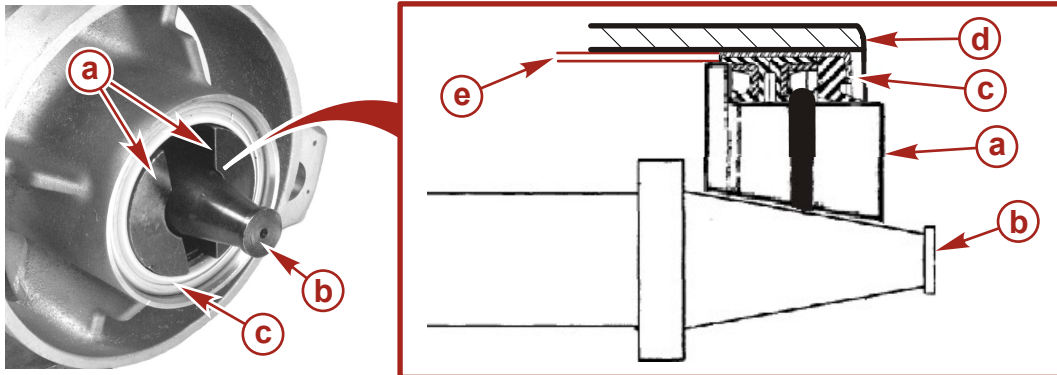

48653

- a - Tool collet
- b - Tool
- c - Seal
- d - Housing
- e - Gap

3. While holding a slight pressure on the tool to keep the collets expanded, position the bearing carrier, with the tool, on a suitable bearing cone tool.

THE INFORMATION IN THIS DOCUMENT IS CONFIDENTIAL AND PROTECTED BY COPYRIGHT AND IS THE PROPERTY OF MERCURY MARINE.

This document is provided for the sole and exclusive use of the original recipient as prescribed by Mercury Marine and may not be distributed or copied, digitally or otherwise, without the prior written consent of Mercury Marine.

- Using an arbor press, press the seal from the bearing carrier.



Pressing the outer propeller shaft seal from the bearing carrier

Removing the Outer Propeller Shaft Needle Bearing

- Position the bearing carrier on a suitable bearing cone tool.
NOTE: Ensure that the bearing cone tool selected is the appropriate depth if you are removing both the outer propeller shaft seal and needle bearing at this time.
- Insert the outer propeller shaft needle bearing removal tool into the bore of the bearing carrier housing and onto the bearing.

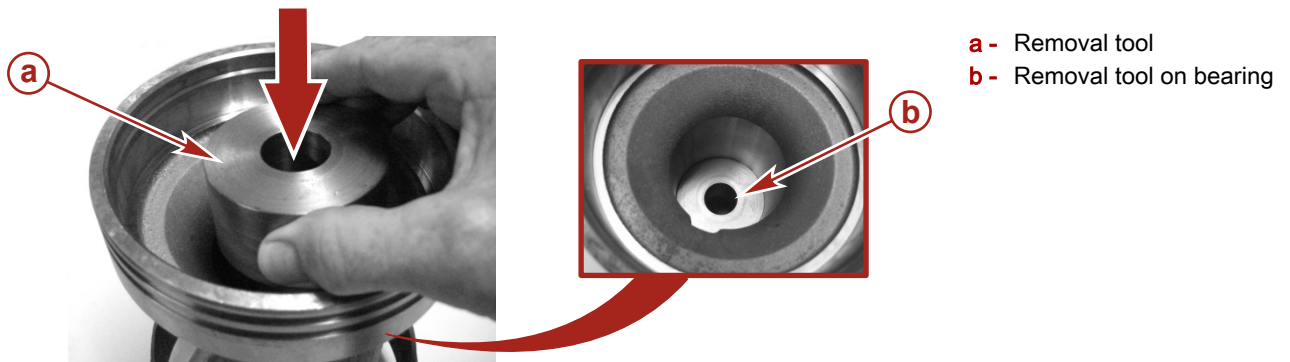

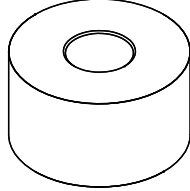
Outer Propeller Shaft Needle Bearing Removal Tool	8M0038271
	Aids in the removal of the outer propeller shaft needle bearing from the bearing carrier.

- Assemble the bearing driver tool from the bearing removal and installation kit to the bearing driver rod from the bearing puller kit.

THE INFORMATION IN THIS DOCUMENT IS CONFIDENTIAL AND PROTECTED BY COPYRIGHT AND IS THE PROPERTY OF MERCURY MARINE.

This document is provided for the sole and exclusive use of the original recipient as prescribed by Mercury Marine and may not be distributed or copied, digitally or otherwise, without the prior written consent of Mercury Marine.

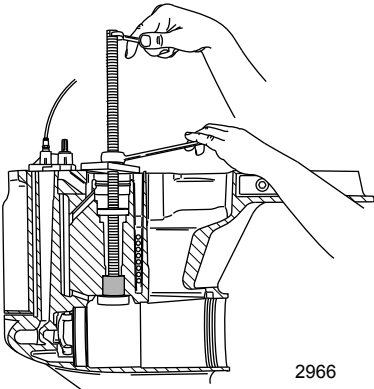
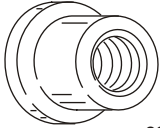
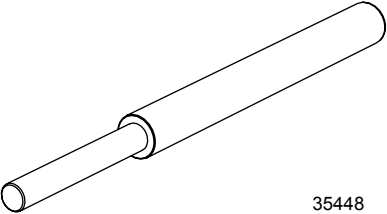
Bearing Removal and Installation Kit	91-31229A7
 <p>2966</p>	<p>Installs and removes the bearings in all gearcases. All components can be purchased separately.</p> <p>91- 31229A 7 tool assembly includes the following components:</p> <ul style="list-style-type: none"> 11- 24156 Hex Nut 12- 34961 Washer 91- 15755T Needle Bearing Driver 91- 29310 Plate 91- 30366T 1 Mandrel 91- 31229 Puller Shaft 91- 32325T Driver Head 91- 32336 Needle Bearing Driver 91- 36379 Puller and Head Gear 91- 36569T Driver Head 91- 36571T Pilot Washer 91- 37292 Roller Bearing 91- 37311 Driver Head 91- 37312T Driver Head 91- 37323 Driver Head Rod 91- 37324T Pilot Washer 91- 37350T Pilot Mandrel 91- 38628T Puller and Driver Head 91- 52393T Pinion Bearing Installation Tool 91- 52394 Head Pull Rod
Driver Head	91- 36569T
 <p>29499</p>	<p>Used in pinion gear and bearing installation and outer propeller shaft needle bearing removal.</p>
Bearing Puller	8M0030457
 <p>35448</p>	<p>Aids in the removal of the spool bearing cup and outer propeller shaft needle bearing removal.</p>

4. Insert the bearing driver rod and driver head into the removal tool.

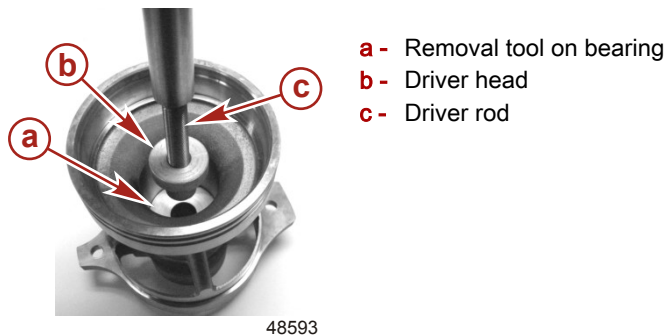

NOTE: The guide plate tool prevents the bearing from becoming cocked during removal.

THE INFORMATION IN THIS DOCUMENT IS CONFIDENTIAL AND PROTECTED BY COPYRIGHT AND IS THE PROPERTY OF MERCURY MARINE.

This document is provided for the sole and exclusive use of the original recipient as prescribed by Mercury Marine and may not be distributed or copied, digitally or otherwise, without the prior written consent of Mercury Marine.

- Place the guide plate tool over the driver rod and center it on the bearing carrier opening.

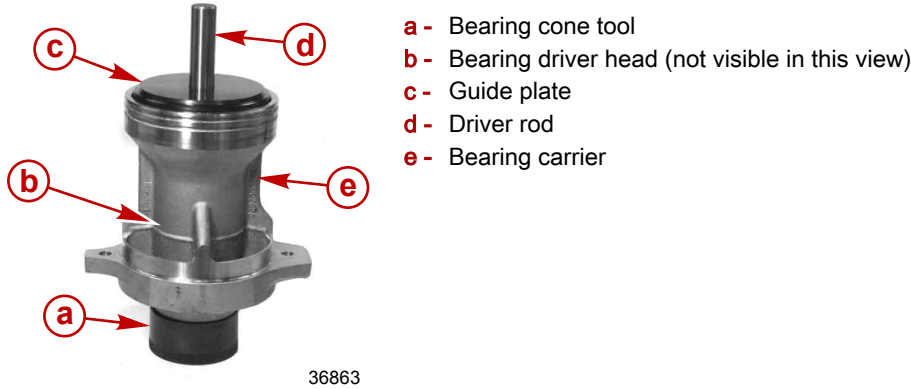

Bearing Carrier Guide Plate Tool	8M0038263
<p>48600</p>	Aids in the removal of the outer propeller shaft needle bearing

- Using a hammer, strike the driver rod to drive the needle bearing (and seal, if still installed) from the bearing carrier.

Rear Gear Bearing Cup and Shim Removal

- Assemble the bearing puller tool by threading it in from the bottom of the three-jaw puller (from the slide hammer tool).

Bearing Puller	8M0030457
<p>35448</p>	Aids in the removal of the rear gear bearing cup.
Slide Hammer	91-34569A 1
<p>6761</p>	Aids in the removal of various engine components. Use with puller jaws.

- Insert the bearing puller tool assembly inside the bearing carrier as shown.

THE INFORMATION IN THIS DOCUMENT IS CONFIDENTIAL AND PROTECTED BY COPYRIGHT AND IS THE PROPERTY OF MERCURY MARINE.

This document is provided for the sole and exclusive use of the original recipient as prescribed by Mercury Marine and may not be distributed or copied, digitally or otherwise, without the prior written consent of Mercury Marine.

NOTE: Position the three-jaw puller so that the jaws are holding the edge of the bearing cup and are not touching the bearing carrier.

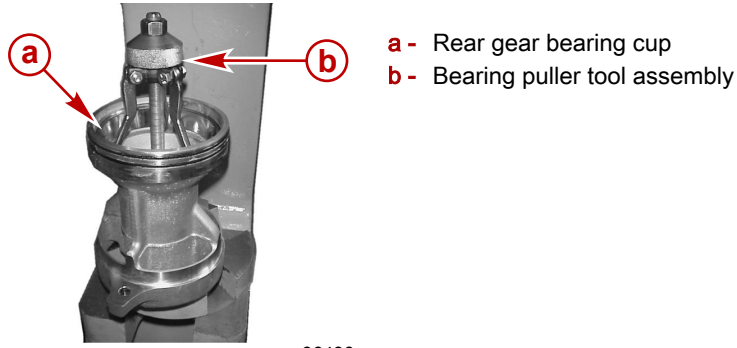

- Turn over the bearing carrier and puller assembly. Position them on a bearing cone driver that is placed on a press.

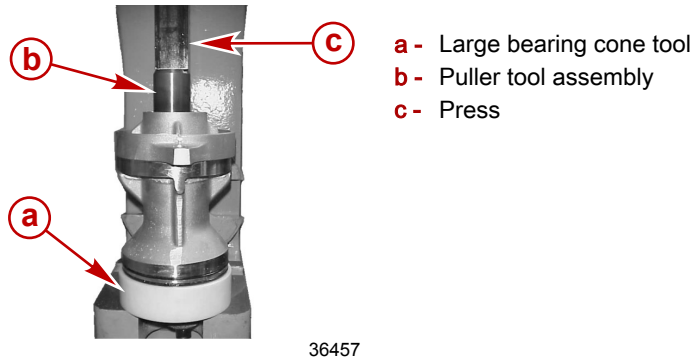

Bearing Cone Driver	8M0030154
<p>35442</p>	Aids the installation of large bearing cones.

- Press the rear gear bearing cup from the bearing carrier.
- Remove the shims for the bearing cup from the bearing carrier. Measure and replace the shims if they are damaged.

THE INFORMATION IN THIS DOCUMENT IS CONFIDENTIAL AND PROTECTED BY COPYRIGHT AND IS THE PROPERTY OF MERCURY MARINE.

This document is provided for the sole and exclusive use of the original recipient as prescribed by Mercury Marine and may not be distributed or copied, digitally or otherwise, without the prior written consent of Mercury Marine.