



Service Bulletin

Bulletin No. 2015-06
OEM No. 2015-05

Circulate to: Sales Manager Accounting Service Manager Technician Parts Manager

NOTE: This service bulletin covers five items. The first two are part of an official recall notification under the U.S. Federal Boat Safety Act (FBSA), while the other three are additional inspections and repairs to be performed at the same time.

Official Recall Notification U.S. Federal Boat Safety Act: #6 Fuel Injector and Water-Separating Fuel Filter Require Inspections

U.S. FBSA Recall Items and Additional Inspections, Repairs, and Replacements

Models Affected

4.5L Sterndrive Engines

Affected Serial Numbers by Issue Addressed

Issue	U.S. FBSA Item?	Starting Serial Number	Ending Serial Number
1 DTS models: fuel injector	Yes	2A441953	2A455152
2 Inlet fuel connection	Yes	2A441953	2A455152
3 Oil line fasteners	No	2A441953	2A452030
4 Standard cooling models: drain valve	No	2A441953	2A452768
5 PCV hose	No	2A441953	2A455152

Scope

Worldwide

Situation

Mercury MerCruiser specified serial numbers of 4.5L models require the following inspections:

- #6 Fuel injector potential interference with the shift actuator on DTS model engines only.
- Water-separating fuel filter housing inlet fuel line connection inspect for wetting or leaks.
- Low torque on the oil line retainer fasteners from connections to cylinder block and remote oil filter adapter.
- Drain valve assemblies with improperly located ball seal on models with standard cooling.
- PCV hose kinked restricting proper ventilation.

Correction

#6 Fuel Injector

IMPORTANT: The affected fuel injector connector is on DTS models within the specified serial number range only. This correction is part of a U.S. Federal Boat Safety Act recall.

Inspect for a blue dot on the number 6 fuel injector connector. If the dot is present, the inspection has been completed. If the dot is not present, perform the following procedure:

THE INFORMATION IN THIS DOCUMENT IS CONFIDENTIAL AND PROTECTED BY COPYRIGHT AND IS THE PROPERTY OF MERCURY MARINE.

This document is provided for the sole and exclusive use of the original recipient as prescribed by Mercury Marine and may not be distributed or copied, digitally or otherwise, without the prior written consent of Mercury Marine.

1. Visually inspect DTS units to ensure that the injector connector is free and not bound by the actuator housing. The injector should rotate freely from the 6 o'clock position to the 8 o'clock position.

NOTE: The 6 o'clock position is defined as perpendicular to the fuel rail, with the 9 o'clock position being parallel to the rail. The 8 o'clock position is therefore at a 30° angle to the fuel rail.

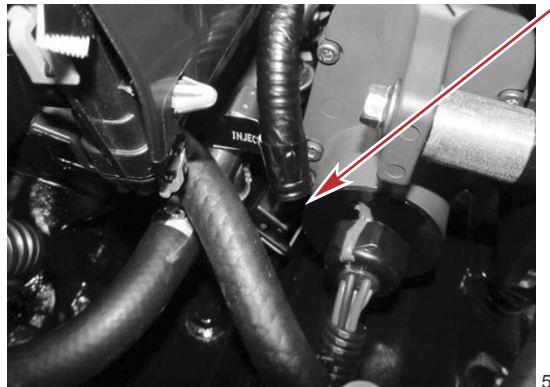

58802

With the injector connector at the 6 o'clock position, it can bind against the actuator housing. Ensure that it is free to turn to the 8 o'clock position.

2. If the injector is found to be bound, loosen the shift bracket assembly from the exhaust manifold and reorient (rotate) the fuel injector to the 8 o'clock position.

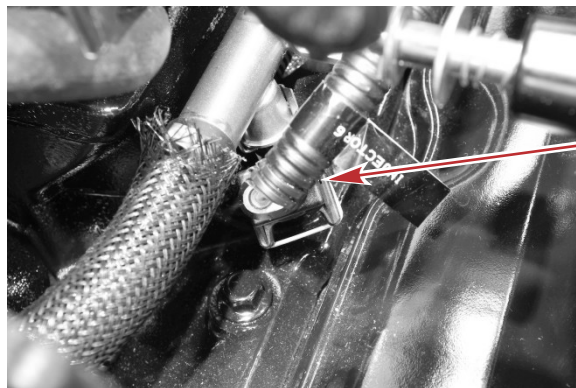

58803

Injector connector positioned at 8 o'clock

3. Tighten the fasteners for the shift bracket assembly to the specified torque.

Description	Nm	lb-in.	lb-ft
Shift bracket assembly fasteners	11.5	102	–

Water-Separating Fuel Filter

IMPORTANT: The affected water-separating fuel filter is on engines within the specified serial number range only. This correction is part of a U.S. Federal Boat Safety Act recall.

Inspect the water-separating fuel filter housing inlet fuel line connection for wetting or leaks. The fuel line is attached via a quick-connect fitting, which allows easy removal if further investigation is needed.

THE INFORMATION IN THIS DOCUMENT IS CONFIDENTIAL AND PROTECTED BY COPYRIGHT AND IS THE PROPERTY OF MERCURY MARINE.

This document is provided for the sole and exclusive use of the original recipient as prescribed by Mercury Marine and may not be distributed or copied, digitally or otherwise, without the prior written consent of Mercury Marine.

If the boat has not yet been fueled and run, then this leak check should be done as part of the pre-delivery inspection (PDI).

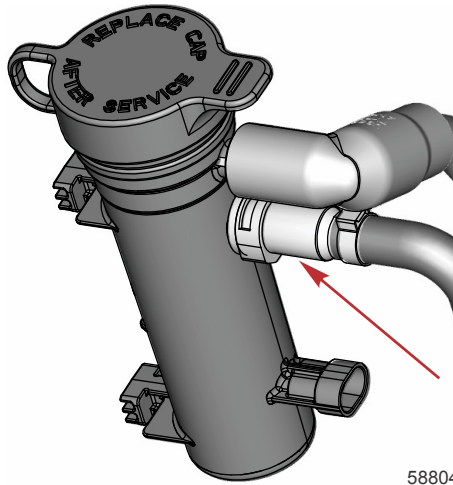

Fuel inlet with quick-connect fitting

Oil Line Fasteners

IMPORTANT: The affected oil line retainer fasteners are on engines within the specified serial number range only. This additional inspection and repair should be performed during the same service visit as the two U.S. FBSA recall inspections.

Inspect the oil line retainer fastener heads for blue paint dots. If the dots are present, then the retorquing procedure has been completed. If the dots are not present, complete the following:

Tighten the fasteners on the oil line retainers at the remote filter base and cylinder block locations to the specified torque, following the indicated torque sequence.

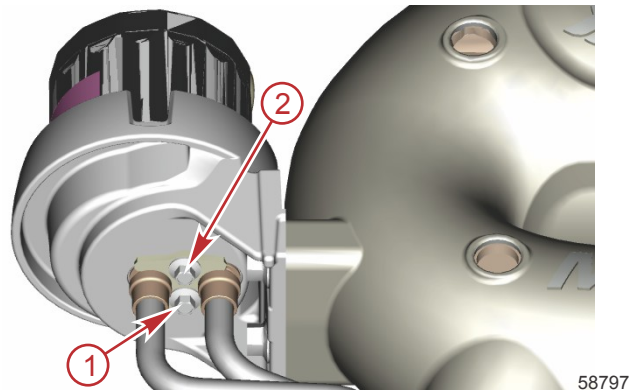

Torque sequence for oil line retainer fasteners at the oil filter

THE INFORMATION IN THIS DOCUMENT IS CONFIDENTIAL AND PROTECTED BY COPYRIGHT AND IS THE PROPERTY OF MERCURY MARINE.

This document is provided for the sole and exclusive use of the original recipient as prescribed by Mercury Marine and may not be distributed or copied, digitally or otherwise, without the prior written consent of Mercury Marine.

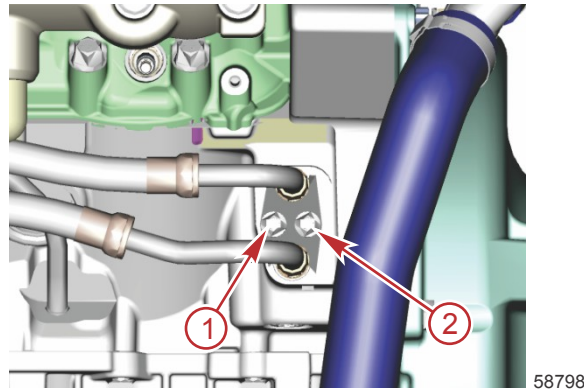

Torque sequence for oil line retainer fasteners at the block

Description		Nm	lb-in.	lb-ft
Oil line retainer fasteners	First Pass	13	115	–
	Final Pass	13	115	–

Manifold Drain Valves

IMPORTANT: The affected manifold drain valves are on standard cooling models within the specified serial number range only. This additional inspection and repair should be performed during the same service visit as the two U.S. FBSA recall inspections.

Inspect the drain valves for green paint dots on the side of the plastic drain fittings. If the dots are present, the valve replacement has been completed. If the dots are not present, replace the drain check valves (two per engine, on the bottom side of the exhaust manifolds) as follows:

1. Drain the seawater from the manifolds. Refer to the appropriate procedure in the **4.5L Mercury MerCruiser Service Manual**.
 - For Bravo models, refer to **Air Actuated Single-Point Drain System—Bravo Seawater Cooling**.
 - For Alpha models, refer to **Manual Single-Point Drain System—Alpha Seawater Cooling**.
2. Disconnect the three hoses from the drain valve assemblies. Retain the hose clamps and hose clamp covers.

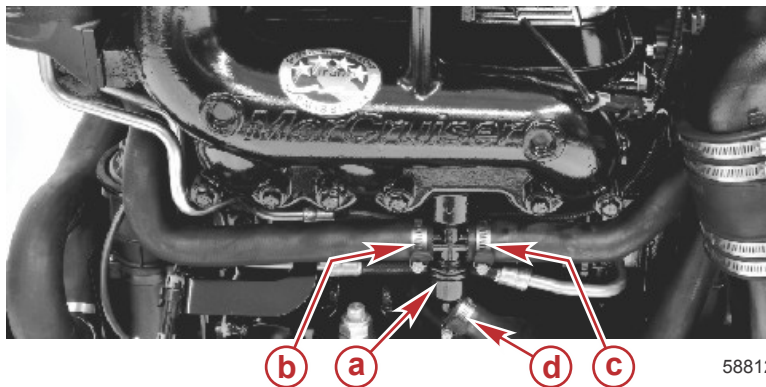

Port side shown, starboard similar

- a - Drain valve assembly
- b - Seawater cooling hose - disconnect
- c - Seawater cooling hose - disconnect
- d - Seawater drain hose - disconnect

3. Remove the drain valve assemblies from the exhaust manifolds. Discard the drain valve assemblies.
4. Install new drain valve assemblies into each manifold by turning them until they are hand-tight. Tighten the assemblies an additional 2-1/2 to 3-1/2 turns. The assemblies should be parallel to the manifold, and the drain (bottom plastic fitting) should angle toward the rear of the engine.
5. Attach the three hoses to each of the drain valve assemblies and secure them with hose clamps. Tighten the hose clamps to the specified torque. Install the retained hose clamp covers onto the hose clamps.

Description	Nm	lb-in.	lb-ft
Hose clamps	4.5	39.8	–

THE INFORMATION IN THIS DOCUMENT IS CONFIDENTIAL AND PROTECTED BY COPYRIGHT AND IS THE PROPERTY OF MERCURY MARINE.

This document is provided for the sole and exclusive use of the original recipient as prescribed by Mercury Marine and may not be distributed or copied, digitally or otherwise, without the prior written consent of Mercury Marine.

6. Close the drain system.
7. After starting the engine, inspect for leaks.

PCV Hose

IMPORTANT: The affected PCV hoses are on engines within the specified serial number range only. This additional inspection and repair should be performed during the same service visit as the two U.S. FBSA recall inspections.

Inspect the PCV hose for a blue paint dot. If the dot is present, then the inspection has been completed. If the dot is not present, inspect the PCV hose as follows:

1. Pull the outside engine cover up to remove it from the four rubber mount grommets.

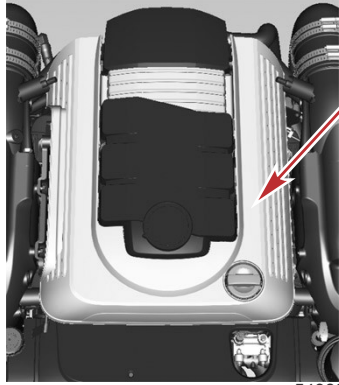

Outside engine cover

2. Inspect the PCV hose for kinks that restrict proper ventilation.

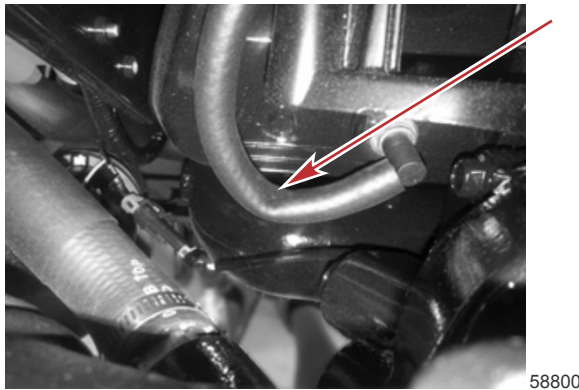

Kink in PCV hose

3. If a kink is found, remove the hose from the PCV valve, and reduce the length such that it reaches the valve but does not kink.
4. Reinstall the hose.
5. Install the outside engine cover.

Parts Required

On specified serial numbers only.

Qty.	Description	Part Number
2*	Drain valve assembly	8M0095953

* Two per engine: one each for port and starboard exhaust manifolds.

THE INFORMATION IN THIS DOCUMENT IS CONFIDENTIAL AND PROTECTED BY COPYRIGHT AND IS THE PROPERTY OF MERCURY MARINE.

This document is provided for the sole and exclusive use of the original recipient as prescribed by Mercury Marine and may not be distributed or copied, digitally or otherwise, without the prior written consent of Mercury Marine.

Owner Notification

A letter will be sent to every registered owner of an affected 4.5L sterndrive powered boat. The letter will advise the owner to take their boat to any Mercury MerCruiser authorized dealer for inspection and necessary repairs. Some affected power packages will have been updated before shipment. Visit MercNET or contact MerCruiser Customer Service or your regional service center to determine whether repairs have already been completed on a given package. As a Mercury MerCruiser dealer, you should also contact affected customers to make them aware of this recall and to schedule an appointment for the repair. A copy of the customer letter is attached.

Warranty Procedure

Submit a warranty claim for **repairs only** through your normal warranty processing channel. Inspections to locate paint dots are not covered by warranty.

Flat Rate Codes

Injector position	SB03
Fuel inlet fitting	SB03
Oil line fasteners retorque	SB02
Drain valves	SB08
PCV hose	SB02
Engine hours from CDS or CDS G3, once per engine	SB02

Part Code: 499

Fail Code: 40

Outside the United States and Canada: Follow the instructions issued by your local office or distributor.

THE INFORMATION IN THIS DOCUMENT IS CONFIDENTIAL AND PROTECTED BY COPYRIGHT AND IS THE PROPERTY OF MERCURY MARINE.

This document is provided for the sole and exclusive use of the original recipient as prescribed by Mercury Marine and may not be distributed or copied, digitally or otherwise, without the prior written consent of Mercury Marine.

OFFICIAL NOTIFICATION OF FEDERAL BOAT SAFETY ACT RECALL

Dear Mercury Marine Customer,

Thank you for your patronage. We at Mercury are dedicated to providing superior product of outstanding quality and reliability. As part of our continuing efforts to exceed our customer's expectations, we have determined that certain unscheduled service to your registered product may be necessary.

What is the Condition?

We have identified a potential issue with the fuel system on your vessel. There is an extremely small likelihood that you may experience a fuel leak, most perceptible after operation. If left unattended, this issue could possibly lead to a hazardous condition. While the dealer has your vessel in for this work, they will perform additional inspections or repairs. You may experience these effects until the situation has been corrected.

What Will We at Mercury Do?

We have provided instructions to our authorized dealers for this service. The required service will be performed at NO COST to you.

What Should You Do?

Contact your authorized Mercury dealer to schedule a service appointment. Be sure to mention Mercury MerCruiser Service Bulletin 2015-06.

Please present this notice to your authorized Mercury dealer at the time of service.

If you have any questions or no longer own this Mercury product, please contact Mercury Marine Customer Assistance, at 1-920-929-5040, between 7:30 AM and 4:30 PM, Central Time.

We have sent this notice in the interest of your continued satisfaction with our product. We sincerely regret any inconvenience this may cause you.

Thank you for boating with Mercury Marine.

Mercury Marine Customer Service