

Replacing an Analog 11350 ECU with a Digital 11350 ECU on 2.5L Hi-Performance Engines

ECU Identification

Analog 11350 ECU's have one access plug on the cover for adjusting fuel mixture.

Digital 11350 ECU's have two access plugs on the cover (one access hole is used to attach the tester and the other is for fuel mixture adjustment).

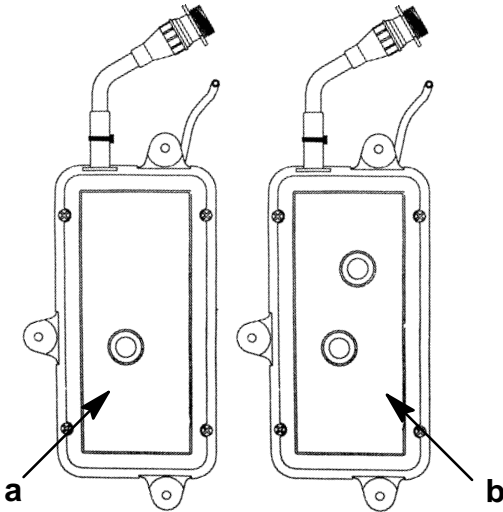

a - Analog 11350 ECU
 b - Digital 11350 ECU

Installation Recommendations

1. Disconnect and remove the Electronic Throttle Position Indicator (TPI).

NOTE: A plug for the TPI connector on the engine can be purchased from Mercury. Order Part No. 848405.

2. Remove and discard T-fitting and short tigon hose between the T-fitting and air inlet plenum fitting. Re-connect fuel pressure regulator tigon hose directly to intake plenum fitting.

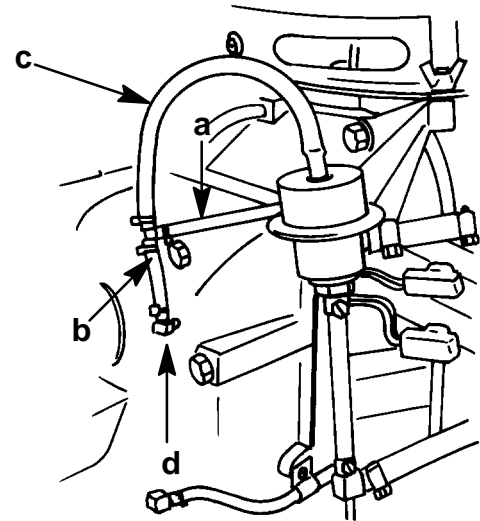

a - Tigon Hose Between Throttle Position Indicator and T-fitting (Remove)
 b - T-fitting and Short Tigon Hose (Remove)
 c - Fuel Pressure Regulator Tigon Hose
 d - Air Inlet Plenum Fitting

3. (If equipped) Some Hi-Performance engines using the A27 ECU's needed a resistor module added to the engine for certain applications. The module was a podded black box with 2 Purple wires coming out of one end and a Yellow/Red wire from the other. Disconnect all resistor module wires and re-install engine wires to their original connections.

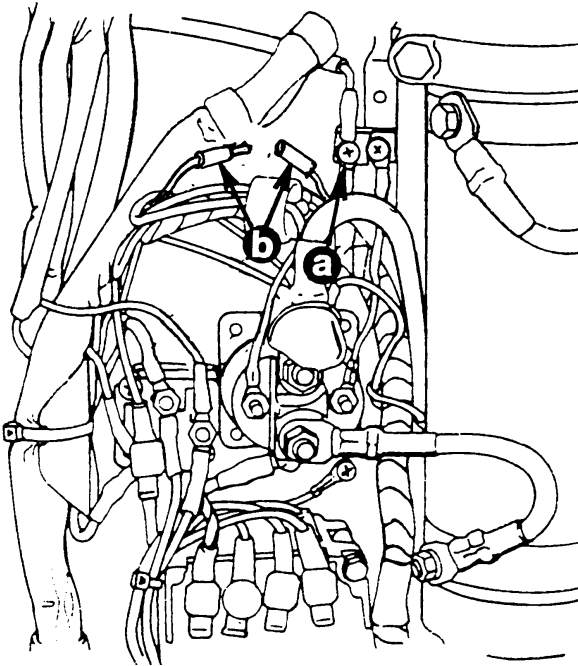

- a - Yel/Red Terminal. Remove Module Wire From Terminal Block.
- b - Purple Wire. Remove Resistor Module Wires and Re-connect Bullet Connectors.

4. The Digital 11350 ECU requires a ground strap to function properly. Install ground strap provided with the ECU between the ECU mounting flange and a good engine ground.

NOTE: ECU units 11350A40 and A49 come with a ground strap. All other Digital ECU's do not. The ground strap part number is 84-65999A10.

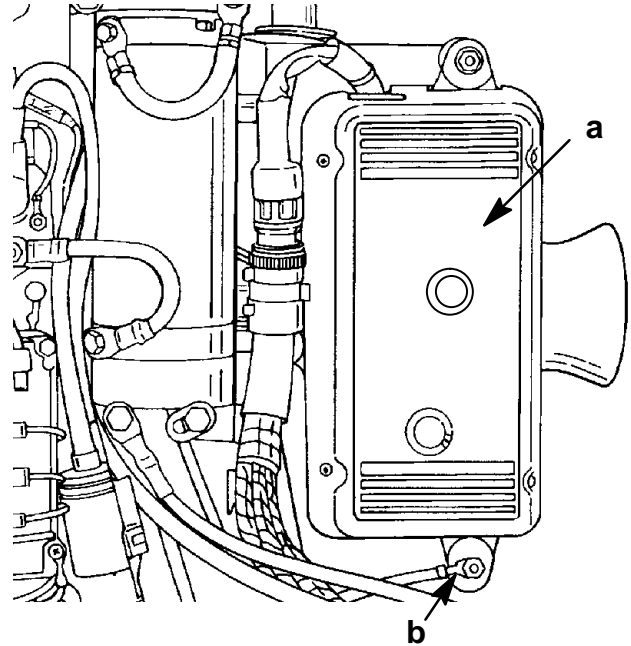

- a - Digital ECU
- b - ECU Ground Strap

5. The Digital ECU should require no adjustments to function well on a stock 2.5 EFI engine. The fuel curve can be adjusted to the engine if required by using the Quicksilver Digital Diagnostic Terminal and proper connecting harnesses.

IMPORTANT: If the engine is to be run during tests using the Quicksilver Digital Diagnostic Terminal, resistor spark plugs (NGK BUZHW P/N 33-14103550) must be used.