

300 Pro Max/Super Magnum, Pinched Oil Line

During installation of the 3.0L powerhead to the mid-section, pinching the transfer oil line (from the oil pump to the oil tank) between the bottom engine plate and the side boss of the powerhead is possible.

This possible "Pinch" is extremely difficult to see due to the hidden location of the transfer oil line (Below and behind the shift slide assembly).

Refer to page 2 of this bulletin for transfer oil line restraint procedure.

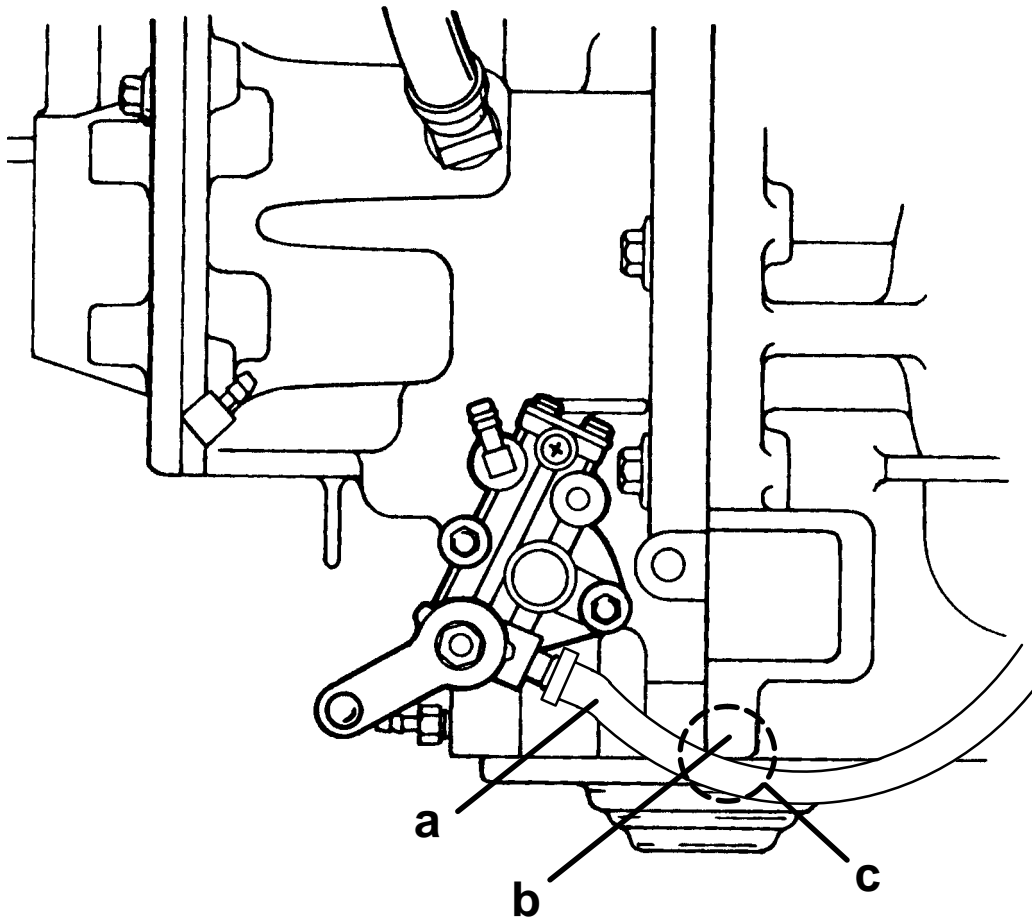

- a - Transfer Oil Line
- b - Powerhead Boss
- c - Possible "Pinch" Area

Transfer Oil Line Restraint

1. While lifting powerhead use a stay-strap, wire tie or a suitable restraint to capture the transfer oil hose to the shift slide assembly.
2. After setting powerhead onto mid-section and securing, remove the restraint from the oil line.

IMPORTANT: Failure to remove transfer oil hose restraint after powerhead installation will cause shift interference.

3. Ensure that the oil transfer line is not pinched between the shift bracket bolt or the base plate attaching bolt head.
4. Plastic protector sleeve over the transfer oil hose should be positioned tight against the oil pump.

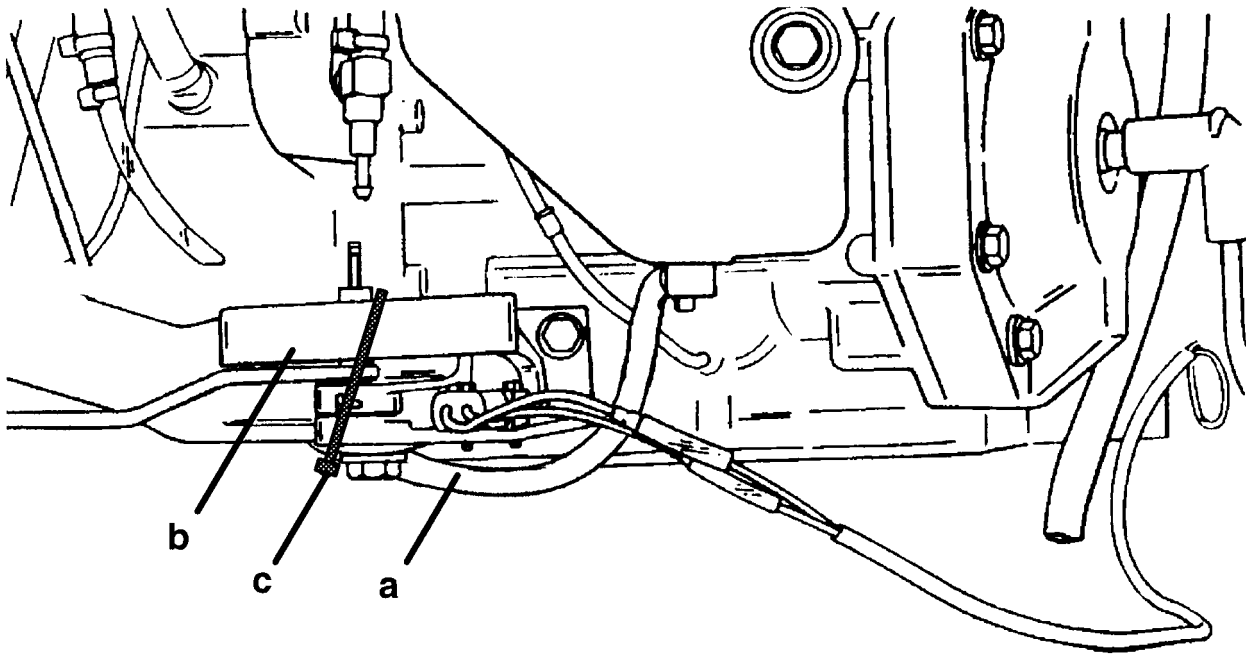

- a - Transfer Oil Line
- b - Shift Bracket Assembly
- c - Oil Line Restraint