

WARRANTY INFORMATION SERVICE INFORMATION
 PARTS INFORMATION

Outboard No. 2002-05

Circulate to: Sales Manager Accounting Service Manager Technician Parts Manager

Use of Tie Bars and Hydraulic Steering on 2003 Model Year 250 XS OptiMax Engines

Situation

The 2003 model year 250 XS uses a mid-section that was not designed for rear tie bar or steering plate mounting. Mounting a rear tie bar or hydraulic steering to the powerhead attaching studs can cause cylinder distortion and premature wear of the powerhead assembly.

Correction

Use only front-mounted tie bars on multiple engine applications of the 250XS. Never attach a tie bar or steering plate to the powerhead mounting bolts.

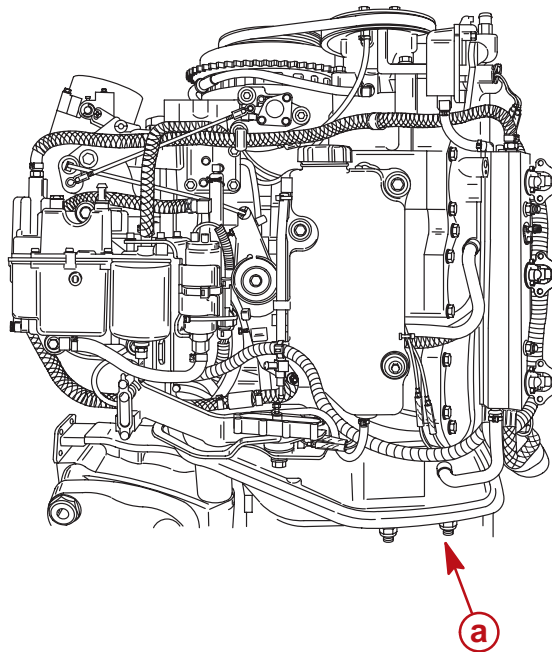

a - Powerhead Mounting Studs.

THE INFORMATION IN THIS DOCUMENT IS CONFIDENTIAL AND PROTECTED BY COPYRIGHT AND IS THE PROPERTY OF MERCURY MARINE.

This document is provided for the sole and exclusive use of the original recipient as prescribed by Mercury Marine and may not be distributed or copied, digitally or otherwise, without the prior written consent of Mercury Marine.

Front Mounted Steering Requirements for the 2003 Model Year 250 XS

- A non-hydraulic dual cable steering system can be used on single engine boats.
- Front mounted hydraulic steering is required on all boats using two or more 250 XS engines.
- One steering cylinder ram is required for each engine on multiple engine boats.
- Boats with three or more engines will require the use of a after market hydraulic steering components.

Warranty

Cylinder block distortion or powerhead problems caused by the mounting of a rear tie bar or hydraulic steering on a 2003 model year 250 XS engine will not be covered by the Mercury Racing Outboard Limited Warranty.

THE INFORMATION IN THIS DOCUMENT IS CONFIDENTIAL AND PROTECTED BY COPYRIGHT AND IS THE PROPERTY OF MERCURY MARINE.

This document is provided for the sole and exclusive use of the original recipient as prescribed by Mercury Marine and may not be distributed or copied, digitally or otherwise, without the prior written consent of Mercury Marine.