



# Service Bulletin

Outboard No. 2017-04  
OEM No. 2017-03

Circulate to:  Sales Manager  Accounting  Service Manager  Technician  Parts Manager

## Torque Master and Torque Master II Gear Housing—Assembly Torque to Driveshaft Housing—Loose Fasteners

### Models Affected

| Models Covered   | Serial Number Or Year |
|--|-----------------------|
| Mercury Racing 3.0L 250XS and 3.2L 300XS outboard models | All                   |

### Scope

Worldwide

### Situation

When performing any service or repair that requires gear housing mounting fastener removal, it is essential to follow the correct tightening sequence and specifications during reinstallation, as described in the service manual. Detailed installation information can be found in the following **Installing the Gear Housing to the Driveshaft Housing** section, or in the appropriate service manual. Failure to tighten fasteners in the correct sequence, and to the correct specifications can cause serious equipment damage, leading to serious or fatal injury to passengers.

THE INFORMATION IN THIS DOCUMENT IS CONFIDENTIAL AND PROTECTED BY COPYRIGHT AND IS THE PROPERTY OF MERCURY MARINE.

This document is provided for the sole and exclusive use of the original recipient as prescribed by Mercury Marine and may not be distributed or copied, digitally or otherwise, without the prior written consent of Mercury Marine.

The images below are examples of damage caused by incorrect torque applied to the mounting fasteners.

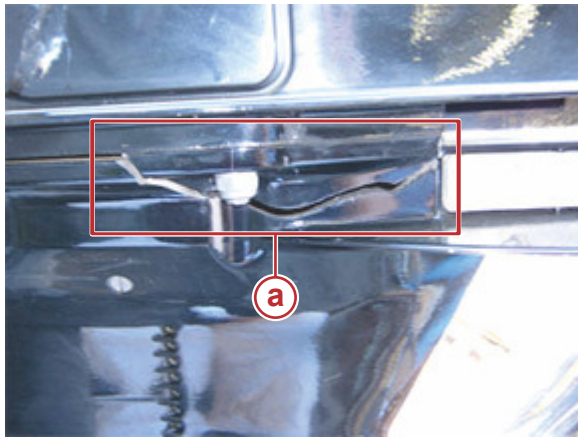

- a - Cracking example 1
- b - Cracking example 2
- c - Gap indicates loose bolt

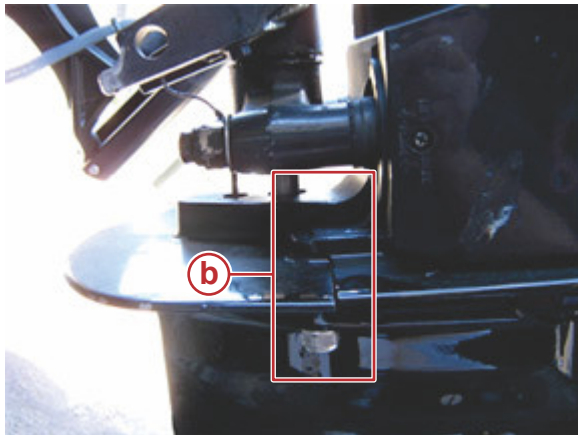

63067

THE INFORMATION IN THIS DOCUMENT IS CONFIDENTIAL AND PROTECTED BY COPYRIGHT AND IS THE PROPERTY OF MERCURY MARINE.

This document is provided for the sole and exclusive use of the original recipient as prescribed by Mercury Marine and may not be distributed or copied, digitally or otherwise, without the prior written consent of Mercury Marine.

## Installing the Gear Housing to the Driveshaft Housing

### ⚠ WARNING

Accidental starting can cause serious injury. Before removing or installing the gear housing, disconnect and isolate the spark plug leads. Disable the ignition system by removing the keys from the ignition (if equipped) and engaging the lanyard stop switch to prevent the engine from starting.

### ⚠ CAUTION

Failure to support the outboard can result in serious injury. Always support the outboard with the tilt-lock lever and support tool when servicing the outboard.

1. Remove the key from the ignition switch and engage the lanyard stop switch.
2. Tilt the engine to the full up position and engage the tilt lock lever. Use caution when tilting the engine with the gearcase removed.
3. Apply a light coat of 2-4-C with PTFE onto the driveshaft splines. Do not allow lubricant on top of the driveshaft.
4. Apply a light coat of 2-4-C with PTFE onto the shift shaft splines. Do not allow lubricant on top of the shift shaft.

| Tube Ref No.   | Description     | Where Used                              | Part No.     |
|--|-----------------|---|--------------|
|  95 | 2-4-C with PTFE | Driveshaft splines; shift shaft splines | 92-802859A 1 |

### NOTICE

Installing the gear housing to the powerhead without adequately cleaning the top of the driveshaft can result in severe product damage. Any lubricant trapped in the space between the driveshaft and the crankshaft prevent the two from properly engaging. Always clean the top of the driveshaft before installing the gear housing.

5. Verify the anode screw is in the rear hole of the gear housing.
6. Verify that the gearcase is in the neutral position.
7. Install the water pump coupler. Lubricate the O-rings in the water pump coupler with 2-4-C with PTFE.

| Tube Ref No.   | Description     | Where Used                 | Part No.     |
|--|-----------------|----------------------------|--------------|
|  95 | 2-4-C with PTFE | Water pump coupler O-rings | 92-802859A 1 |

8. Install the shift shaft coupler.

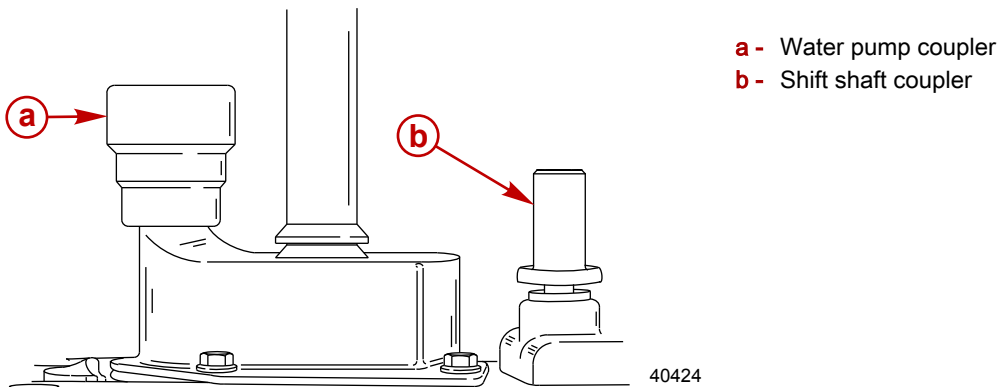

9. Verify that the upper shift shaft, and the guide block with anchor pin are in the neutral position.
10. Position the gear housing so the driveshaft is protruding into the driveshaft housing.

THE INFORMATION IN THIS DOCUMENT IS CONFIDENTIAL AND PROTECTED BY COPYRIGHT AND IS THE PROPERTY OF MERCURY MARINE.

This document is provided for the sole and exclusive use of the original recipient as prescribed by Mercury Marine and may not be distributed or copied, digitally or otherwise, without the prior written consent of Mercury Marine.

- Push the speedometer tubing into the Legris fitting on the gear housing.

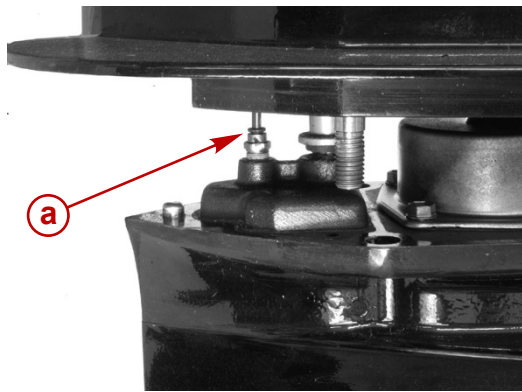

a - Legris fitting

40278

- Move the gear housing up toward the driveshaft housing while aligning the shift shaft splines and water tube.
 

**NOTE:** If the driveshaft splines will not align with the crankshaft splines, rotate the flywheel slightly to reposition the splines.
- Ensure the water tube is properly aligned and installed into the water pump coupler.
 

**IMPORTANT:** Engine overheating can occur if the water tube is not correctly installed.

**⚠ WARNING**

Avoid serious injury or death resulting from catastrophic drivetrain failure. Improper installation of the gear housing onto the driveshaft housing can cause severe equipment damage, leading to serious or fatal injury to passengers. Ensure that the mounting hardware is tightened in the correct sequence and to the correct torque specifications.

- Secure the gear housing assembly with four nuts and washers. Do not tighten the nuts at this time.
- Start the screw at the rear of the gear housing inside the anode recess. Do not tighten the screw at this time.

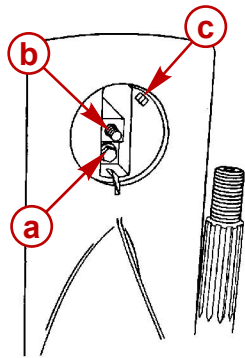

a - Screw securing the gear housing assembly  
 b - Anode plate screw  
 c - Anode tabs

3233

- Check the shift shaft spline engagement and correct if necessary.
- Tighten the nuts to the specified torque.
 

**IMPORTANT:** Do not force the gear housing up into place with the attaching nuts and screw.

| Description | Nm | lb-in. | lb-ft |
|-------------|----|--------|-------|
| Nuts        | 61 | –      | 45    |

- Tighten the screw located at the rear of the gear housing inside the anode recess to the specified torque.

| Description                              | Nm | lb-in. | lb-ft |
|--|----|--------|-------|
| Screw securing the gear housing assembly | 75 | –      | 55.3  |

- Install the anode plate and secure with the screw. Tighten the screw to the specified torque.

| Description       | Nm | lb-in. | lb-ft |
|-------------------|----|--------|-------|
| Anode plate screw | 54 | –      | 39.8  |

THE INFORMATION IN THIS DOCUMENT IS CONFIDENTIAL AND PROTECTED BY COPYRIGHT AND IS THE PROPERTY OF MERCURY MARINE.

This document is provided for the sole and exclusive use of the original recipient as prescribed by Mercury Marine and may not be distributed or copied, digitally or otherwise, without the prior written consent of Mercury Marine.

20. Install the plastic cap onto the driveshaft housing.



THE INFORMATION IN THIS DOCUMENT IS CONFIDENTIAL AND PROTECTED BY COPYRIGHT AND IS THE PROPERTY OF MERCURY MARINE.

This document is provided for the sole and exclusive use of the original recipient as prescribed by Mercury Marine and may not be distributed or copied, digitally or otherwise, without the prior written consent of Mercury Marine.