

Circulate to:  Sales Manager  Accounting  Service Manager  Technician  Parts Manager

## Joystick Piloting for Outboard (JPO) Vessel Upgrade

NOTICE
Revised May 2018. This bulletin supersedes the previous bulletin number 2017-08 November 2017.
The bulletin includes revisions to the following procedures:
<ul style="list-style-type: none"> <li>System Checklist</li> </ul>

### Affected Boat Serial Numbers

All JPO boats manufactured with a hull identification number (HIN) date prior to G717 (July 2017) are within the scope of this bulletin. The manufacture date (month, year, model year) is located in the ninth through twelfth position in the hull identification number.

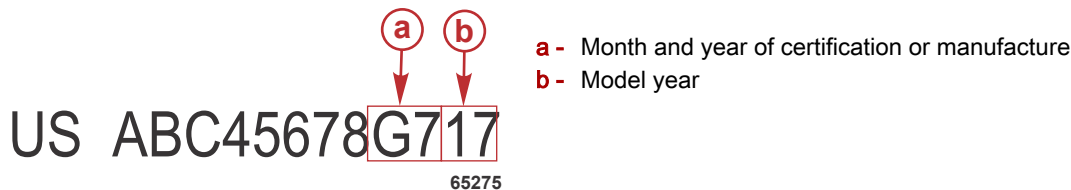

A—January	G—July
B—February	H—August
C—March	I—September
D—April	J—October
E—May	K—November
F—June	L—December

### Scope

Worldwide

### Situation

Mercury Marine has identified a potential issue with the power steering pump which may affect steering performance. The power steering pump may intermittently shut down, causing the steering not to function on the affected engine. Power steering pumps must be inspected and, if necessary, replaced. The operation software must also be validated to ensure it is up-to-date and, if necessary, reflashed to the current software version. Additionally, a critical system and operations checklist must be completed. The system checklist is included with this bulletin.

**IMPORTANT: A copy of the system checklist must be delivered to the Mercury Marine Warranty Department. Failure to return a completed checklist will result in the claim being denied.**

Return completed System Checklist to:

- Warranty claims fax: 920-906-6033
- Email: [outboardwarranty@mercmarine.com](mailto:outboardwarranty@mercmarine.com)

THE INFORMATION IN THIS DOCUMENT IS CONFIDENTIAL AND PROTECTED BY COPYRIGHT AND IS THE PROPERTY OF MERCURY MARINE.

This document is provided for the sole and exclusive use of the original recipient as prescribed by Mercury Marine and may not be distributed or copied, digitally or otherwise, without the prior written consent of Mercury Marine.

## OEM/Dealer Inventory

Inventory must be inspected and, if necessary, updated according to this bulletin, prior to delivering to the customer.

## Owner Notification

A customer letter will be mailed to all registered owners, notifying them that their Mercury Marine JPO boat requires an unscheduled service inspection. As a Mercury Marine dealer, you should contact affected customers to advise them of this service bulletin and schedule a service appointment. A copy of the letter is included with this service bulletin.

**Limited Time Offer Only to the Registered Boat Owner:** During this time when the vessel system is upgraded and inspected, we are offering to install VesselView Mobile in the boat if it is not already equipped—no charge to the registered boat owner. This offer is not extended past this system upgrade/inspection service appointment. If the customer does not want the VesselView Mobile system installed, the customer must tell the dealer not to install the VesselView Mobile.

## Correction

1. Remove the cover of the power steering pump.
2. Inspect the pump motor body for a green color paint dot. This dot will be located aft of the wire harness exiting the pump motor body. Refer to the following picture.

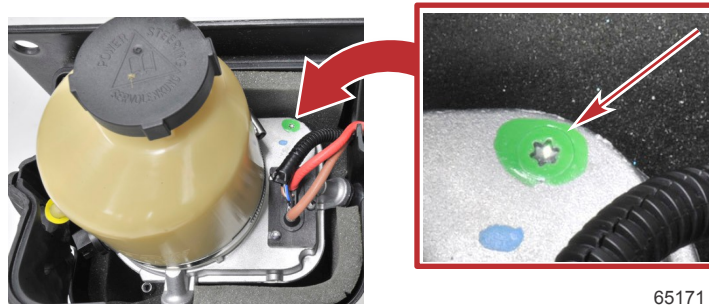

Green color paint dot

3. If the power steering pump body is not marked with a green color paint dot, a new power steering pump assembly must be ordered, installed, and the system purged of air. Refer to the appropriate service manual or installation manual on how to purge the power steering system of air.
4. Review reflash outboard service bulletins 2016-11R3 and 2016-12R3.
5. Connect CDS G3 to the engine and verify the software listed in the previous two bulletins are uploaded into the vessel operating system. If the software is not uploaded, perform the steps outlined in the bulletins to complete the reflash.
6. After completing the previous steps, complete the system checklist included with this bulletin. The system checklist must be completed and delivered to the Mercury Marine Warranty Department to process the warranty claim approval.
7. If the customer has agreed to the VesselView Mobile special offer, install the VesselView Mobile system if not already equipped and assist the owner with downloading the app and setup. Instructions for the installation and setup are included with the device.

## Parts Information

- 8M0134736—power steering pump replacement
- 8M0115080—VesselView Mobile
- Refer to outboard service bulletins 2016-11R3 and 2016-12R3 for possible additional parts

## Warranty

Warranty outside the United States and Canada: Follow instructions issued by your local office or distributor.

Mercury Marine will credit the dealer for the cost of parts, labor, and completed checklist.

Submit a warranty claim through your normal warranty-processing channel for each engine, listing:

- Starboard engine
  - a. Serial number
  - b. Power steering pump part number (if replaced)

THE INFORMATION IN THIS DOCUMENT IS CONFIDENTIAL AND PROTECTED BY COPYRIGHT AND IS THE PROPERTY OF MERCURY MARINE.

This document is provided for the sole and exclusive use of the original recipient as prescribed by Mercury Marine and may not be distributed or copied, digitally or otherwise, without the prior written consent of Mercury Marine.

- c. Power steering pump: part code 804, fail code 40
- d. Power steering pump flat rate code: **SB10** (1.0 hour)
- e. Check list flat rate: **SB25** (2.5 hours)
- f. VesselView Mobile part number (if installed)
- g. VesselView Mobile: part code 640, fail code 99
- h. VesselView Mobile flat rate code: SB05 (0.5 hour)
- Port engine
  - a. Serial number
  - b. Power steering pump part number (if replaced)
  - c. Power steering pump: part code 804, fail code 40
  - d. Power steering pump flat rate code: **SB10** (1.0 hour)
- Starboard inner engine (if equipped)
  - a. Serial number
  - b. Power steering pump part number (if replaced)
  - c. Power steering pump: part code 804, fail code 40
  - d. Power steering pump flat rate code: **SB10** (1.0 hour)
- Port inner engine (if equipped)
  - a. Serial number
  - b. Power steering pump part number (if replaced)
  - c. Power steering pump: part code 804, fail code 40
  - d. Power steering pump flat rate code: **SB10** (1.0 hour)

## System Checklist

An editable copy of the following System Checklist can be found on the MercNET website home page.

### Boat Information

Step	Check	Notes/Action Items			Complete
1	Manufacture name				
2	Boat model				
3	HIN				
4	Number of engines				
5	Number of helms				
6	Engine serial number and hours	Port			
		Port inner			
		Starboard inner			
		Starboard			
7	Steering cylinder serial number: Reference Mercury Outboard SB 17-09	Port			
		Port inner			
		Starboard inner			
		Starboard			

THE INFORMATION IN THIS DOCUMENT IS CONFIDENTIAL AND PROTECTED BY COPYRIGHT AND IS THE PROPERTY OF MERCURY MARINE.

This document is provided for the sole and exclusive use of the original recipient as prescribed by Mercury Marine and may not be distributed or copied, digitally or otherwise, without the prior written consent of Mercury Marine.

## G3 Diagnostic Tool

Step	Check	Notes/Action Items	Complete
1	Create full report and save for later review	From G3 home screen select <b>File &gt; Print Full Report</b> . When full report window opens, click on the gear icon, add customer information, click <b>Finish</b> . Click <b>Export to PDF</b> . When the save file window opens, select the desktop as the destination and name the file using the customer name and boat model. Click <b>Save</b> .	
2	Check for software updates on G3 home screen	Perform appropriate reflash bulletin as directed by G3: outboard service bulletin 2016-11R3 for design 1 joysticks, or outboard service bulletin 2016-12R3 for design 2 joysticks.	
3	Verify vessel personality (VSL) file is loaded	Use the <a href="#">Technical Assistance Request</a> form located on MercNet to obtain the VSL file from the Mercury Technical Service department. In G3 go to: <b>Configuration &gt; Personality &gt; Vessel Personality</b> . The VSL name will be displayed in the upper right hand corner of the screen.	
4	Manual drive alignment is verified	In G3 go to: <b>Configuration &gt; Drive Configuration &gt; Manual Drive Alignment &gt; Joystick Piloting Outboard</b> . Follow the instructions to start the test. When the steering angle boxes are shown, any number other than 0.0 in each box is OK. If 0.0 is displayed in both boxes, the manual drive alignment needs to be completed. If the vessel is out of the water, follow the manual drive alignment steps outlined in the JPO Diagnostic Service Manual 8M0110489, page 5A-9.	

## Main Electrical Connections

Locate batteries and positive/ground connection studs for the following and correct any issues found.

Step	Check	Notes/Action Items	Complete
1	Order of cables installed	Largest cable first to smallest with no more than four per connection.	
2	Ring terminal size	Ring terminal of cable (ID) should be slightly smaller than OD of the stud. If ID of ring terminal is too large, then nut may loosen and lead to power steering pump shutting down.	
3	Lockwashers are installed	A flat washer should be installed before the lockwasher. Order of assembly—battery cable > flat washer > lockwasher > hex nut.	
4	All nuts are tightened	Specification 13.5 Nm (120 lb-in.)	

## Power Steering Pump

Step	Check	Notes/Action Items	Complete
1	Install new design power steering pump (if required)	Reference the instructions included with the kit.	
2	Power steering pump fluid level is full	Fluid should be between the two lines on the cap/dipstick. Fill if necessary.	
3	If the current sensor is installed on the power steering fuse, check the fuse connections	Pull on each fuse wire to ensure the wires are properly seated in the fuse holder. If wires are loose, reinsert into fuse holder and recheck.	

## Steering System Components

The following steps will verify that the components are installed on the correct battery.

**IMPORTANT:** Turn all key switches to the off position before starting the verification procedure. Complete each step in the indicated sequence beginning with the starboard engine and starboard modules. After all 9 steps have been completed for the starboard engine, proceed to the port engine. Complete the steps in the indicated sequence for each of the remaining engines and their respective modules.

THE INFORMATION IN THIS DOCUMENT IS CONFIDENTIAL AND PROTECTED BY COPYRIGHT AND IS THE PROPERTY OF MERCURY MARINE.

This document is provided for the sole and exclusive use of the original recipient as prescribed by Mercury Marine and may not be distributed or copied, digitally or otherwise, without the prior written consent of Mercury Marine.

**IMPORTANT:** Complete each step in the indicated sequence beginning with the starboard engine and starboard modules first. Then repeat the procedure for each remaining engine and the engine's respective modules.

Step	Check	Notes/Action Items	Complete	Next Step
1	Move the remote control handle to the reverse wide-open throttle (RWOT) position.		Complete <input type="checkbox"/>	Continue to step 2
2	Turn off all battery switches.	Port, port inner, starboard inner, starboard, and multibattery switches if equipped.	Complete <input type="checkbox"/>	Continue to step 3
3	Turn the dedicated (to the engine that is being verified) battery switch to the <b>ON</b> position.	All other battery switches must remain in the <b>OFF</b> position. Only the battery switch that powers the engine system that is being verified should be on. Do not use the <b>All</b> position of a multibattery switch for this procedure.	Complete <input type="checkbox"/>	Continue to step 4
4	Turn the engine key switch to the <b>ON</b> position.	The engine key switch must be powered by the battery switch that is in the <b>ON</b> position.	Complete <input type="checkbox"/>	Continue to step 5
5	Use the <b>Module Data</b> page in CDS G3 to verify that all of the corresponding engine modules are on-line.	Only the CCM, TVM, and helm modules that correspond to the engine system that is being verified should appear in the <b>Module Data</b> screen. By example, if the starboard engine key switch is on, then the <b>HELM 1 STBD CCM</b> , the <b>STBD TVM</b> , and the <b>STBD ENGINE</b> should appear in the <b>Module Data</b> screen. When the port, port inner, or starboard inner engine key switch is in the <b>ON</b> position then only the corresponding modules for the engine that is being verified should appear in the <b>Module Data</b> screen. If the modules do not appear in the module data screen when the corresponding key switch is on then a connection problem is indicated.	Complete <input type="checkbox"/>	Continue to step 6
6	Start the engine.	Does the engine start? If yes, continue to the next step. If no, identify which engine is running and correct the crossed 14-pin harness.	Complete <input type="checkbox"/>	Continue to step 7
7	With the engine running, is the power steering pump on? Verify by feeling for pump vibration.	If the power steering pump is not on, check the following: <ol style="list-style-type: none"> <li>1. The power steering pump is connected to the correct battery. (Quad tie bar applications use an automatic power switch.)</li> <li>2. The TVM 3-pin power steering signal harness is connected to the correct power steering pump. Correct any connection issues.</li> </ol>	Complete <input type="checkbox"/>	Continue to step 8
8	With the engine running, turn the steering wheel. Does the engine turn?	If not, identify which engine is turning and correct the crossed 6-pin TVM to steering cylinder connection.	Complete <input type="checkbox"/>	Continue to step 9

THE INFORMATION IN THIS DOCUMENT IS CONFIDENTIAL AND PROTECTED BY COPYRIGHT AND IS THE PROPERTY OF MERCURY MARINE.

This document is provided for the sole and exclusive use of the original recipient as prescribed by Mercury Marine and may not be distributed or copied, digitally or otherwise, without the prior written consent of Mercury Marine.

Step	Check	Notes/Action Items	Complete	Next Step
9	With the engine running and using G3, monitor TVM live data—Current_Measured.	<p>With the engine and pump running the value should be above 5 amps. The Current_Measured value should increase while the engine is turning.</p> <ol style="list-style-type: none"> <li>If the reading is 0.1 amp–0.2 amps the current sensor is not connected to the correct power steering pump battery connection.</li> <li>If the reading is 65535 amps (default), the current sensor is not connected to the TVM. Correct any connection issues.</li> <li>Turn the steering wheel, the Current_Measured value should increase while the engine is turning.</li> </ol> <p><b>NOTE:</b> If the reading does not change, ensure that the power steering pump pressure and return lines are connected to the correct engine. (Check the lines from the power steering pump to bulkhead fitting and bulkhead fitting to engine.)</p>	Complete <input type="checkbox"/>	Turn the key switch to the <b>OFF</b> position and continue to the next engine.

## Steering Cylinder

Refer to the following graphic illustration to identify the step locations.

Step	Check	Notes/Action Items	Complete
1	Link rod between actuator extension tube and tie bar arm can be rocked fore and aft	Apply 2-4-C with PTFE to the link rod extension arm ball joint at the tie bar arm.	
2	Steering cylinder link rod nut is properly tightened	Top and bottom washers should spin freely. Tighten the nut to 13.5 Nm (120 lb-in.) then back off 1/4 turn.	
3	No grease in the steering cylinder extension tube	Clean with mild solvent spray if grease is found. Apply engine oil to the steering cylinder.	
4	Steering cylinder plastic 90° elbow is installed correctly—secured to the actuator with cable ties	If elbow is missing, order and install elbow.	
5	Steering cylinder 6-pin electrical harness on transom is loose and not restrained within 15.3 cm (6 in.) of the cylinder	If the harness is too tight, it will restrict movement which will lead to little or no hydraulic assist and cause steering follow faults.	
6	Steering cylinder 6-pin electrical harness is routed below the anticollision cable	If routed above, disconnect anticollision cable and route the electrical cable below.	
7	Steering cylinder assembly is not obstructed	Turn steering wheel lock-to-lock; ensure no interference or contact with other components or the bulkhead.	
8	Steering cylinder motor has unobstructed movement near antirotation bracket (item 11 in illustration)	<p>With the engine running, rotate the steering wheel rapidly 1/4 turn back and forth while watching the electric motor of the steering cylinder near the antirotation bracket: electric motor should move approximately 6.35 mm (0.25 in.) total.</p> <p><b>NOTE:</b> G3 JPO steering system bleed test can be utilized for 250 hp and 300 hp (2B144123 and up) and all 350 hp and 400R hp engines.</p>	

THE INFORMATION IN THIS DOCUMENT IS CONFIDENTIAL AND PROTECTED BY COPYRIGHT AND IS THE PROPERTY OF MERCURY MARINE.

This document is provided for the sole and exclusive use of the original recipient as prescribed by Mercury Marine and may not be distributed or copied, digitally or otherwise, without the prior written consent of Mercury Marine.

Step	Check	Notes/Action Items	Complete
9	Steering cylinder extension tube (silver piston) indexing is correct	<p>In G3, go to TVM live data. Monitor <b>Drive_Pos_Pri_ADC</b> and <b>Drive_Pos_Sec_ADC</b>. Move the engine so the values are within 5 of each other. Perfect center is 512 but that may vary depending on the TVM 5 V reference circuit. Measure from the end of the spool to the end of the extension tube. The measurement must be <math>11.747 \pm 0.157</math> cm (<math>4.625 \pm 0.062</math> in.). See JPO Diagnostic Service Manual 8M0110489, page 3F-2 steering cylinder indexing. <a href="#">Actuator Indexing Video</a></p>	
10	Perform the maximum power output test to check the health of the cylinder. Test in water only! Testing on land will not be accurate.	<ol style="list-style-type: none"> <li>1. Remove the power steering pump fuse for the suspect engine.</li> <li>2. Disconnect the power steering current sensor.</li> <li>3. Start all engines.</li> <li>4. In G3, go to TMV live data. Monitor <b>SteerMotor_Current</b> and <b>Steer_Motor_DutyCycle</b>, record the data for review.</li> <li>5. Turn the steering wheel lock-to-lock rapidly. Slow steering wheel movement will result in a lower amp reading. If the reading on <b>SteerMotor_Current</b> is below 10000mA when the <b>Steer_Motor_DutyCycle</b> is 100%, contact Mercury Technical Service for a replacement steering cylinder.</li> </ol> <p><b>NOTE:</b> All steering cylinders must be returned to Mercury Marine for testing. <a href="#">Actuator Maximum power Test Video</a></p>	

THE INFORMATION IN THIS DOCUMENT IS CONFIDENTIAL AND PROTECTED BY COPYRIGHT AND IS THE PROPERTY OF MERCURY MARINE.

This document is provided for the sole and exclusive use of the original recipient as prescribed by Mercury Marine and may not be distributed or copied, digitally or otherwise, without the prior written consent of Mercury Marine.

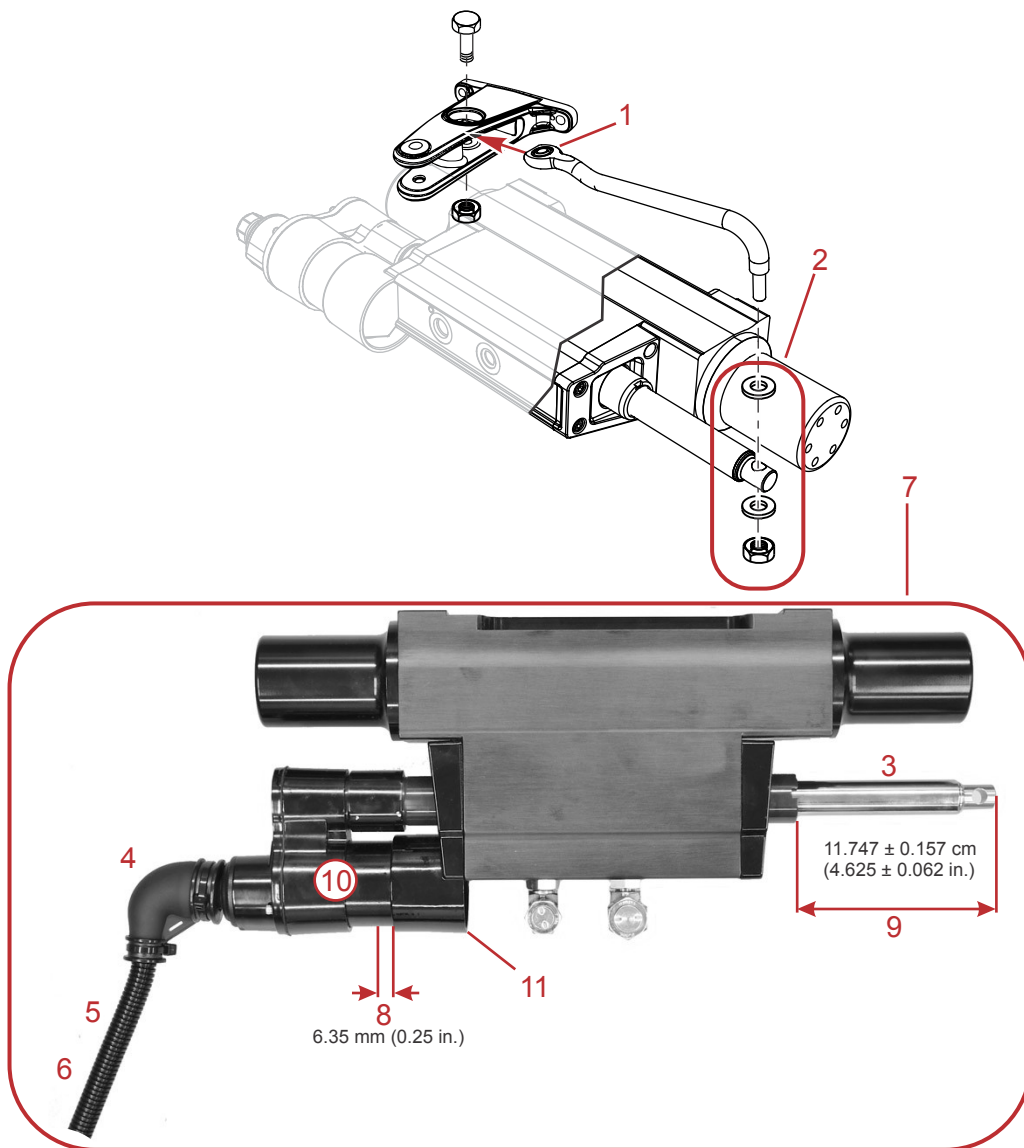

66760

Step locations—steering cylinder

## Anticollision Cable

Step	Check	Notes/Action Items	Complete
1	Rigging tube is routed above the anticollision cable	If below, disconnect the cable and reposition the rigging tube above the cable.	
2	Correct length anticollision cable for the engine drive separation	Verify the engines do not contact each other. With all engines running, slowly turn engines lock-to-lock, the anticollision cable should not be stretched tight at full lock. If it is stretched tight the cable is too short. With only one engine running, turn the steering wheel, if the engines contact each other, the anticollision cable is too long. Verify engine center to center mounting distance matches what is called out in the vessel personality details. Contact Mercury Tech Service for assistance if the anticollision cable is too long, too short, or if the engine center to center mounting distance does not match the specification found in the vessel personality details.	

THE INFORMATION IN THIS DOCUMENT IS CONFIDENTIAL AND PROTECTED BY COPYRIGHT AND IS THE PROPERTY OF MERCURY MARINE.

This document is provided for the sole and exclusive use of the original recipient as prescribed by Mercury Marine and may not be distributed or copied, digitally or otherwise, without the prior written consent of Mercury Marine.



Step	Check	Notes/Action Items	Complete
3	Anticollision cable installed correctly so spring forces cable towards the bow	With engines centered, the anticollision cable ends should point slightly forward.	

### Thrust Vector Module (TVM)

Step	Notes/Action Items	Complete
Check for evidence of water near the TVM	Correct any source of water ingress near the TVM. Verify rod holder drains or water hose routing near the TVMs are secure and directed away from the TVM.	

### General Rigging

Step	Check	Notes/Action Items	Complete
1	Verify all unused electrical connections have a weather cap installed	Ensure any unused engine or helm connections have a weather cap installed. At the helm, check the J-Box, and 2-pin CAN links. Check the unused 3-pin power steering signal harness connector at the engine. If the vessel is equipped with a design 2 joystick system, check the unused analog wheel connector and the analog joystick connector at the helm.	
2	Ensure all 14-pin connections are tight	Manually check the 14-pin connections are tight at the following locations: <ul style="list-style-type: none"> <li>• At the engine</li> <li>• TVM</li> <li>• Helm</li> </ul>	
3	Design 1 joystick systems only: Helm 20-amp fuse clean power harness is connected to starboard engine battery switch (switch side)	Locate and inspect the connection (circuit breaker or fuse are OK if connected to the engine battery switch [switch side]). <b>IMPORTANT: Design 2 joystick applications do not utilize the 20-amp helm fuse.</b>	
4	Verify the battery type and rating	USA	Type: AGM
			Rating: 800 MCA, 650 CCA
			RC: 25
		EN (International)	Type: AGM
			Rating: 975 CCA
			Ah: 65

### System Function

Step	Check	Notes/Action Items	Complete
1	Joystick functionality	Vessel responds in direction the Joystick is moved	
2	Steers normal	Lock-to-lock steering shows no signs of binding or hesitation	
3	Overall engine operation systems	No faults are generated	
4	Clear all module faults and freeze frame	In G3 go to the <b>Module Data</b> , highlight each module individually, click <b>Freeze Frame</b> on the top of the screen, click on the gear icon > <b>Clear History</b> . Repeat for all PCMs, TVMs, and CCMs.	

THE INFORMATION IN THIS DOCUMENT IS CONFIDENTIAL AND PROTECTED BY COPYRIGHT AND IS THE PROPERTY OF MERCURY MARINE.

This document is provided for the sole and exclusive use of the original recipient as prescribed by Mercury Marine and may not be distributed or copied, digitally or otherwise, without the prior written consent of Mercury Marine.

## System Checklist

### Boat Information

Step	Check	Notes/Action Items	Complete	
1	Manufacturer name			
2	Boat model			
3	HIN			
4	Number of engines			
5	Number of helms			
6	Engine serial number and hours	Port		
		Port inner		
		Starboard inner		
		Starboard		
7	Steering cylinder serial number: Reference SB 17-09	Port		
		Port inner		
		Starboard inner		
		Starboard		

### G3 Diagnostic Tool

Step	Check	Notes/Action Items	Complete
1	Create full report and save for later review	From G3 home screen select <b>File &gt; Print Full Report</b> . When full report window opens, click on the gear icon, add customer information, click <b>Finish</b> . Click <b>Export to PDF</b> . When the save file window opens, select the desktop as the destination and name the file using the customer name and boat model. Click <b>Save</b> .	
2	Check for software updates on G3 home screen	Perform appropriate reflash bulletin as directed by G3: outboard service bulletin 2016-11R3 for design 1 joysticks, or outboard service bulletin 2016-12R3 for design 2 joysticks.	
3	Verify vessel personality (VSL) file is loaded	Use the <a href="#">Technical Assistance Request</a> form located on MercNet to obtain the VSL file from the Mercury Technical Service department. In G3 go to: <b>Configuration &gt; Personality &gt; Vessel Personality</b> . The VSL name will be displayed in the upper right hand corner of the screen.	
4	Manual drive alignment is verified	In G3 go to: <b>Configuration &gt; Drive Configuration &gt; Manual Drive Alignment &gt; Joystick Piloting Outboard</b> . Follow the instructions to start the test. When the steering angle boxes are shown, any number other than 0.0 in each box is OK. If 0.0 is displayed in both boxes, the manual drive alignment needs to be completed. If the vessel is out of the water, follow the manual drive alignment steps outlined in the JPO Diagnostic Service Manual 8M0110489, page 5A-9.	

### Main Electrical Connections

Locate batteries and positive/ground connection studs for the following and correct any issues found.

Step	Check	Notes/Action Items	Complete
1	Order of cables installed	Largest cable first to smallest with no more than four per connection.	
2	Ring terminal size	Ring terminal of cable (ID) should be slightly smaller than OD of the stud. If ID of ring terminal is too large, then nut may loosen and lead to power steering pump shutting down.	
3	Lockwashers are installed	A flat washer should be installed before the lockwasher. Order of assembly—battery cable > flat washer > lockwasher > hex nut.	
4	All nuts are tightened	Specification 13.5 Nm (120 lb-in.)	

## Power Steering Pump

Step	Check	Notes/Action Items	Complete
1	Install new design power steering pump (if required)	Reference the instructions included with the kit.	
2	Power steering pump fluid level is full	Fluid should be between the two lines on the cap/dipstick. Fill if necessary.	
3	If the current sensor is installed on the power steering fuse, check the fuse connections	Pull on each fuse wire to ensure the wires are properly seated in the fuse holder. If wires are loose, reinsert into fuse holder and recheck.	

## Steering System Components

The following steps will verify that the components are installed on the correct battery.

**IMPORTANT:** Turn all key switches to the off position before starting the verification procedure. Complete each step in the indicated sequence beginning with the starboard engine and starboard modules. After all 9 steps have been completed for the starboard engine, proceed to the port engine. Complete the steps in the indicated sequence for each of the remaining engines and their respective modules.

**IMPORTANT:** Complete each step in the indicated sequence beginning with the starboard engine and starboard modules first. Then repeat the procedure for each remaining engine and the engine's respective modules.

Step	Check	Notes/Action Items	Complete	Next Step
1	Move the remote control handle to the reverse wide-open throttle (RWOT) position.		Complete <input type="checkbox"/>	Continue to step 2
2	Turn off all battery switches.	Port, port inner, starboard inner, starboard, and multibattery switches if equipped.	Complete <input type="checkbox"/>	Continue to step 3
3	Turn the dedicated (to the engine that is being verified) battery switch to the <b>ON</b> position.	All other battery switches must remain in the <b>OFF</b> position. Only the battery switch that powers the engine system that is being verified should be on. Do not use the <b>All</b> position of a multibattery switch for this procedure.	Complete <input type="checkbox"/>	Continue to step 4
4	Turn the engine key switch to the <b>ON</b> position.	The engine key switch must be powered by the battery switch that is in the <b>ON</b> position.	Complete <input type="checkbox"/>	Continue to step 5
5	Use the <b>Module Data</b> page in CDS G3 to verify that all of the corresponding engine modules are on-line.	Only the CCM, TVM, and helm modules that correspond to the engine system that is being verified should appear in the <b>Module Data</b> screen. By example, if the starboard engine key switch is on, then the <b>HELM 1 STBD CCM</b> , the <b>STBD TVM</b> , and the <b>STBD ENGINE</b> should appear in the <b>Module Data</b> screen. When the port, port inner, or starboard inner engine key switch is in the <b>ON</b> position then only the corresponding modules for the engine that is being verified should appear in the <b>Module Data</b> screen. If the modules do not appear in the module data screen when the corresponding key switch is on then a connection problem is indicated.	Complete <input type="checkbox"/>	Continue to step 6
6	Start the engine.	Does the engine start? If yes, continue to the next step. If no, identify which engine is running and correct the crossed 14-pin harness.	Complete <input type="checkbox"/>	Continue to step 7
7	With the engine running, is the power steering pump on? Verify by feeling for pump vibration.	If the power steering pump is not on, check the following: <ol style="list-style-type: none"> <li>1. The power steering pump is connected to the correct battery. (Quad tie bar applications use an automatic power switch.)</li> <li>2. The TVM 3-pin power steering signal harness is connected to the correct power steering pump. Correct any connection issues.</li> </ol>	Complete <input type="checkbox"/>	Continue to step 8

Step	Check	Notes/Action Items	Complete	Next Step
8	With the engine running, turn the steering wheel. Does the engine turn?	If not, identify which engine is turning and correct the crossed 6-pin TVM to steering cylinder connection.	Complete <input type="checkbox"/>	Continue to step 9
9	With the engine running and using G3, monitor TVM live data—Current_Measured.	<p>With the engine and pump running the value should be above 5 amps. The Current_Measured value should increase while the engine is turning.</p> <ol style="list-style-type: none"> <li>If the reading is 0.1 amp–0.2 amps the current sensor is not connected to the correct power steering pump battery connection.</li> <li>If the reading is 65535 amps (default), the current sensor is not connected to the TVM. Correct any connection issues.</li> <li>Turn the steering wheel, the Current_Measured value should increase while the engine is turning.</li> </ol> <p><b>NOTE:</b> If the reading does not change, ensure that the power steering pump pressure and return lines are connected to the correct engine. (Check the lines from the power steering pump to bulkhead fitting and bulkhead fitting to engine.)</p>	Complete <input type="checkbox"/>	Turn the key switch to the <b>OFF</b> position and continue to the next engine.

## Steering Cylinder

Refer to the following graphic illustration to identify the step locations.

Step	Check	Notes/Action Items	Complete
1	Link rod between actuator extension tube and tie bar arm can be rocked fore and aft	Apply 2-4-C with PTFE to the link rod extension arm ball joint at the tie bar arm.	
2	Steering cylinder link rod nut is properly tightened	Top and bottom washers should spin freely. Tighten the nut to 13.5 Nm (120 lb-in.) then back off 1/4 turn.	
3	No grease in the steering cylinder extension tube	Clean with mild solvent spray if grease is found. Apply engine oil to the steering cylinder.	
4	Steering cylinder plastic 90° elbow is installed correctly—secured to the actuator with cable ties	If elbow is missing, order and install elbow.	
5	Steering cylinder 6-pin electrical harness on transom is loose and not restrained within 15.3 cm (6 in.) of the cylinder	If the harness is too tight, it will restrict movement which will lead to little or no hydraulic assist and cause steering follow faults.	
6	Steering cylinder 6-pin electrical harness is routed below the anticollision cable	If routed above, disconnect anticollision cable and route the electrical cable below.	
7	Steering cylinder assembly is not obstructed	Turn steering wheel lock-to-lock; ensure no interference or contact with other components or the bulkhead.	
8	Steering cylinder motor has unobstructed movement near antirotation bracket (item 11 in illustration)	<p>With the engine running, rotate the steering wheel rapidly 1/4 turn back and forth while watching the electric motor of the steering cylinder near the antirotation bracket: electric motor should move approximately 6.35 mm (0.25 in.) total.</p> <p><b>NOTE:</b> G3 JPO steering system bleed test can be utilized for 250 hp and 300 hp (2B144123 and up) and all 350 hp and 400R hp engines.</p>	

Step	Check	Notes/Action Items	Complete
9	Steering cylinder extension tube (silver piston) indexing is correct	<p>In G3, go to TVM live data. Monitor <b>Drive_Pos_Pri_ADC</b> and <b>Drive_Pos_Sec_ADC</b>. Move the engine so the values are within 5 of each other. Perfect center is 512 but that may vary depending on the TVM 5 V reference circuit. Measure from the end of the spool to the end of the extension tube. The measurement must be <math>11.747 \pm 0.157</math> cm (<math>4.625 \pm 0.062</math> in.). See JPO Diagnostic Service Manual 8M0110489, page 3F-2 steering cylinder indexing.</p> <p><a href="#">Actuator Indexing Video</a></p>	
10	Perform the maximum power output test to check the health of the cylinder. Test in water only! Testing on land will not be accurate.	<ol style="list-style-type: none"> <li>1. Remove the power steering pump fuse for the suspect engine.</li> <li>2. Disconnect the power steering current sensor.</li> <li>3. Start all engines.</li> <li>4. In G3, go to TMV live data. Monitor <b>SteerMotor_Current</b> and <b>Steer_Motor_DutyCycle</b>, record the data for review.</li> <li>5. Turn the steering wheel lock-to-lock rapidly. Slow steering wheel movement will result in a lower amp reading. If the reading on <b>SteerMotor_Current</b> is below 10000mA when the <b>Steer_Motor_DutyCycle</b> is 100%, contact Mercury Technical Service for a replacement steering cylinder.</li> </ol> <p><b>NOTE:</b> All steering cylinders must be returned to Mercury Marine for testing.</p> <p><a href="#">Actuator Maximum power Test Video</a></p>	

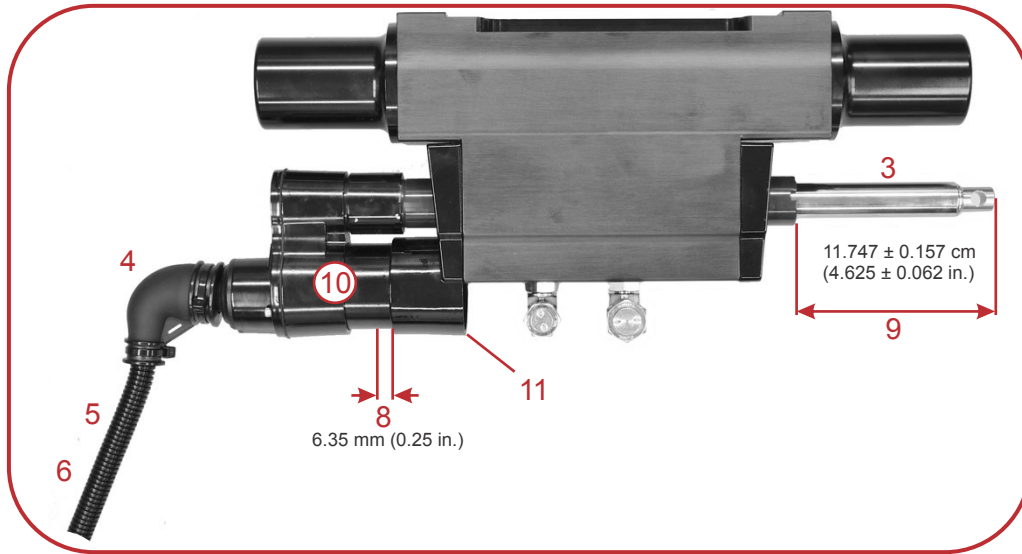
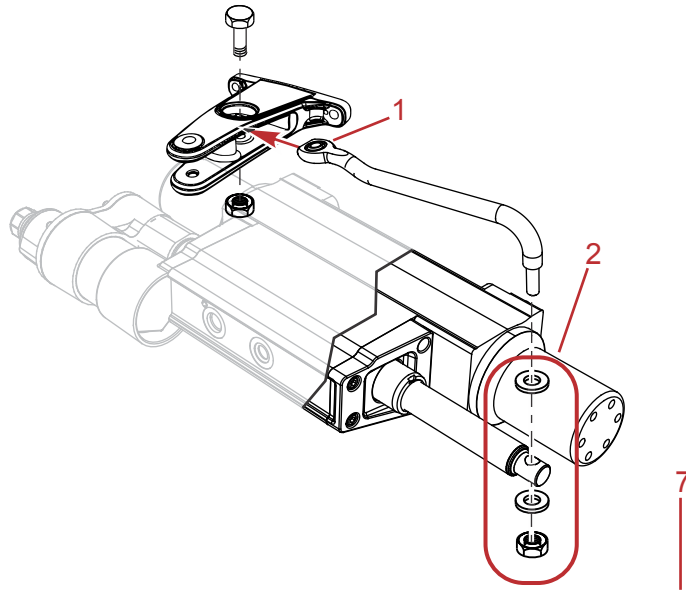

66760

Step locations—steering cylinder

## Anticollision Cable

Step	Check	Notes/Action Items	Complete
1	Rigging tube is routed above the anticollision cable	If below, disconnect the cable and reposition the rigging tube above the cable.	
2	Correct length anticollision cable for the engine drive separation	Verify the engines do not contact each other. With all engines running, slowly turn engines lock-to-lock, the anticollision cable should not be stretched tight at full lock. If it is stretched tight the cable is too short. With only one engine running, turn the steering wheel, if the engines contact each other, the anticollision cable is too long. Verify engine center to center mounting distance matches what is called out in the vessel personality details. Contact Mercury Tech Service for assistance if the anticollision cable is too long, too short, or if the engine center to center mounting distance does not match the specification found in the vessel personality details.	

Step	Check	Notes/Action Items	Complete
3	Anticollision cable installed correctly so spring forces cable towards the bow	With engines centered, the anticollision cable ends should point slightly forward.	

## Thrust Vector Module (TVM)

Step	Notes/Action Items	Complete
Check for evidence of water near the TVM	Correct any source of water ingress near the TVM. Verify rod holder drains or water hose routing near the TVMs are secure and directed away from the TVM.	

## General Rigging

Step	Check	Notes/Action Items	Complete
1	Verify all unused electrical connections have a weather cap installed	Ensure any unused engine or helm connections have a weather cap installed. At the helm, check the J-Box, and 2-pin CAN links. Check the unused 3-pin power steering signal harness connector at the engine. If the vessel is equipped with a design 2 joystick system, check the unused analog wheel connector and the analog joystick connector at the helm.	
2	Ensure all 14-pin connections are tight	Manually check the 14-pin connections are tight at the following locations: <ul style="list-style-type: none"> <li>At the engine</li> <li>TVM</li> <li>Helm</li> </ul>	
3	Design 1 joystick systems only: Helm 20-amp fuse clean power harness is connected to starboard engine battery switch (switch side)	Locate and inspect the connection (circuit breaker or fuse are OK if connected to the engine battery switch [switch side]). <b>IMPORTANT: Design 2 joystick applications do not utilize the 20-amp helm fuse.</b>	
4	Verify the battery type and rating	USA	Type: AGM
			Rating: 800 MCA, 650 CCA
			RC: 25
		EN (International)	Type: AGM
			Rating: 975 CCA
			Ah: 65

## System Function

Step	Check	Notes/Action Items	Complete
1	Joystick functionality	Vessel responds in direction the Joystick is moved	
2	Steers normal	Lock-to-lock steering shows no signs of binding or hesitation	
3	Overall engine operation systems	No faults are generated	
4	Clear all module faults and freeze frame	In G3 go to the <b>Module Data</b> , highlight each module individually, click <b>Freeze Frame</b> on the top of the screen, click on the gear icon > <b>Clear History</b> . Repeat for all PCMs, TVMs, and CCMs.	