

Trim System Replacement – 1995 40 & 50 HP

1995 Force
40 and 50 hp
S/N OE094432 thru OE096618

Durability testing has found the potential for stuck check valves on some trim systems in this serial number range. Stuck check valves will make the trim system inoperable. Trim systems with Day of Year code 138 thru 158 are suspect and should be replaced. The Day of Year code is found on the top of the rod eye.

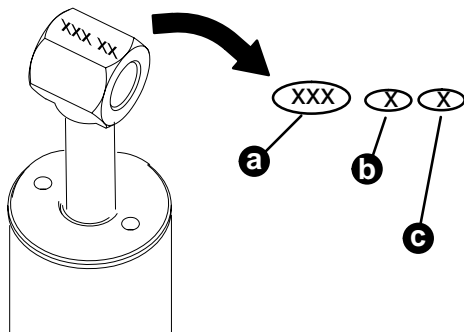

- a - Day of Year
- b - Year
- c - Revision Level - (Letter A or No Letter)

Figure 1. Trim System Identification

NOTE: The motors listed in this bulletin are also a part of the recall announced in Service Bulletin 95-1. Please check the power trim while performing the work involved in that bulletin.

OWNER NOTIFICATION:

Dealers are asked to contact owners of engines within this serial number range sold by your dealership. Ask owners to return their outboard for inspection of the Day of Year code and possible replacement of the trim system.

DEALER STOCK:

Inspect outboards within this serial number range for the Day of Year code. Replace trim systems with Day of Year codes 138 thru 158.

INSPECTION:

Tilt engine up with the electric trim system. Or, turn release valve 3 turns counterclockwise and manually tilt the engine. Secure the engine with the tilt lock lever.

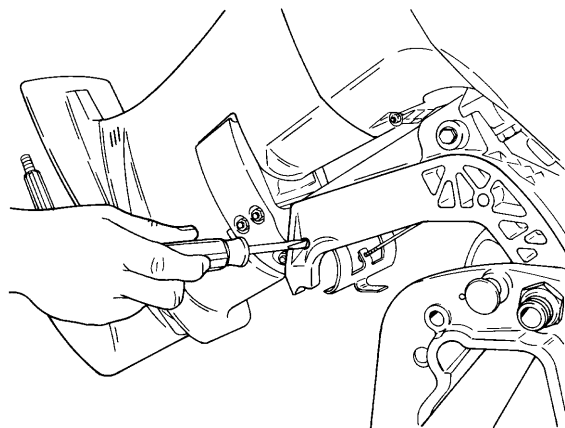

53412

Figure 2. Manual Release Valve

Remove lock pin and upper pivot pin. Retract trim rod and read Day of Year code on top of rod eye.

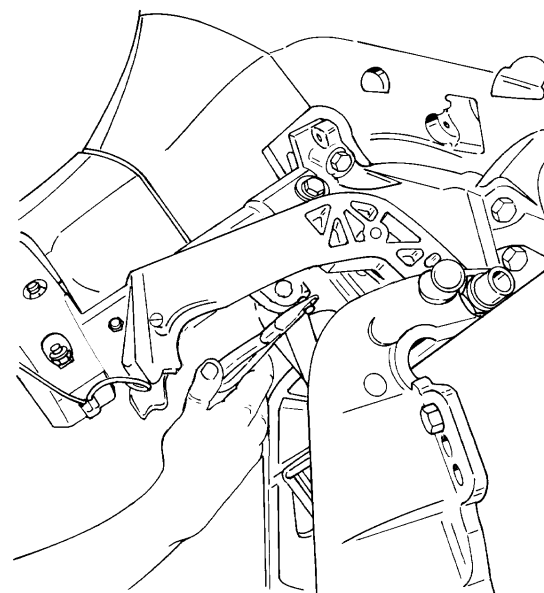

53406

Figure 3. Lock Pin Removal

Reassemble upper pivot pin and lock pin if Day of Year code is other than 138 thru 158.

Replace with P/N 822344A 3 trim system if Day of Year code is 138 thru 158.

Disconnect battery cables and trim system wiring. Remove the zinc anode and the trim system. Install new trim system and removed anode.

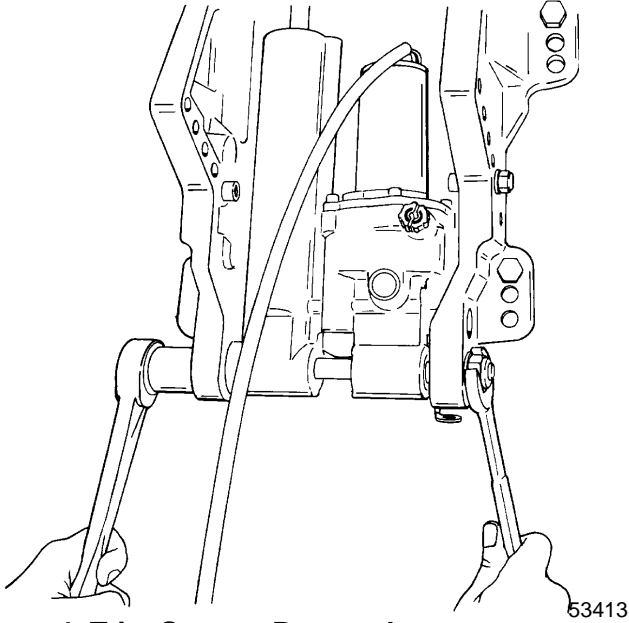

Figure 4. Trim System Removal

Reconnect external trim system wiring.

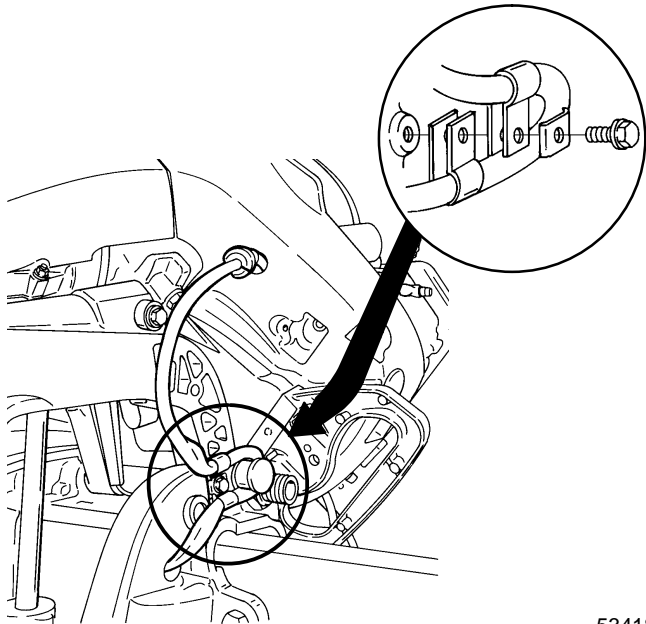
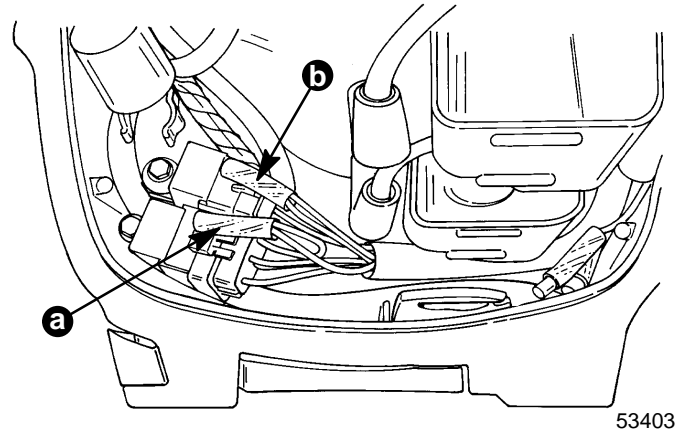

Figure 5. External Wiring

Reconnect internal trim system wiring. Reconnect battery cables and test system for proper function.



a - Green Wire
b - Blue Wire

Figure 6. Internal Wiring

WARRANTY:

Complete warranty claim listing:

Inspection:

Outboard Serial Number
One half (0.5) hour labor
Warranty labor code : NJC
Failure code 119 15

Or

Replacement:

Outboard Serial Number
Qty. 1 822344A 3 Trim System
One and two tenths (1.2) hour labor – for replacement
Warranty labor code : OH 45
Failure code 119 15

USA and Canada – Return original trim system with warranty claim.

International – Hold original trim system for inspection/disposition by a Marine Power International Technical Representative.