

Special Tools

Models Affected

MERCURY, MARINER AND FORCE

SPARK GAP TOOL P/N 91-850439

This new spark gap tool has 8 terminals, and is enclosed to eliminate open spark. May be used on any Mercury/Mariner/Force outboard, except 1997, 200 HP Direct Fuel Injection (DFI) outboards. The non-suppressed spark in the tool will cause electrical interference in the Electronic Control Module (ECM). It may be used on 1998, and later DFI product.

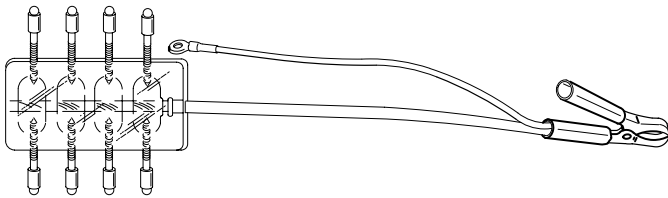

55117

COIL SETTING TOOL P/N 91-830230T

1994 and Later Force 9.9/15 HP

S/N 0E035000 and UP

All Force 25 HP, 3 Cylinder engines

This tool will provide an accurate air gap setting of the ignition coils. The tool looks similar to a flywheel with a large opening, to expose the ignition coils.

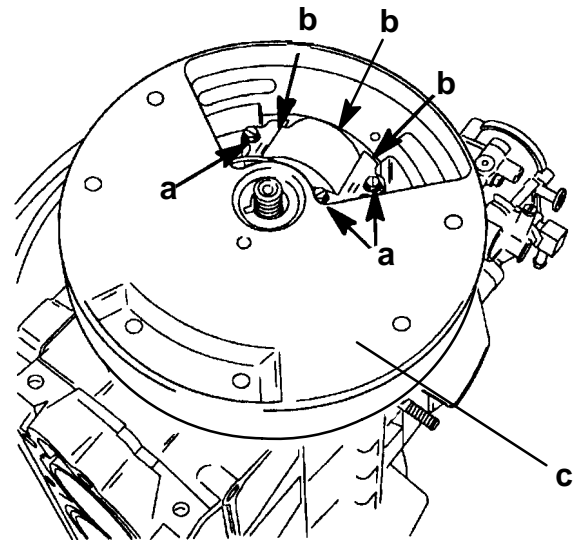

- a - Coil Mounting Screws
- b - Coil Laminations
- c - Coil Setting Tool 91-830230T

ALL CYLINDER TIMING DECALS

Decals can be used for troubleshooting ignition timing problems. The decal has a self sticking adhesive, that allows the decal to be installed on the flywheel, timing can then be checked on each cylinder. The decal can be used one time only, they will be sold 10 to a package. Shown below is a typical 3 cylinder decal (not to scale).

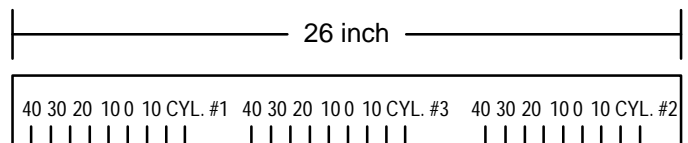

- **P/N 91-853883 1**

Mercury/Mariner 50/55/60 HP, 3 Cylinder with ADI ignition
USA - S/N 0D000750 and UP
Belgium S/N 9683055 and UP

Mercury/Mariner 40/50/55/60 HP, 3 Cylinder with CDM ignition

USA- S/N 0G531301 and UP

Belgium S/N 9973100 and UP

Mercury/Mariner 70 thru 90 HP, 3 Cylinder with ADI ignition

USA - S/N 0A996142 thru 0D283221

Belgium S/N 9483121 thru 09793576

- **P/N 91-853883 2**

Mercury/Mariner 100 thru 125 HP, 4 Cylinder

USA - S/N 0B209468 and UP

Belgium S/N 9937000 and UP

- **P/N 91-853883 3**

Mercury/Mariner 135 thru 250 V-6 with one piece Cast flywheel (non-flex plate style)

INJECTOR TEST HARNESS P/N 91-833169A1

Mercury/Mariner 150 thru 250 HP with Electronic Fuel Injection (EFI).

Hi-Performance 150 thru 300 HP PRO MAX/SUPER MAGNUM models only.

Can be used to verify that the ECM is supplying operating voltage to the injectors. Harness is connected between the injector harness and the engine harness. Harness is used in conjunction with DVA meter P/N 91-99750A1. Harness will also serve as a convenient way to connect to the injector harness to perform injector resistance test.

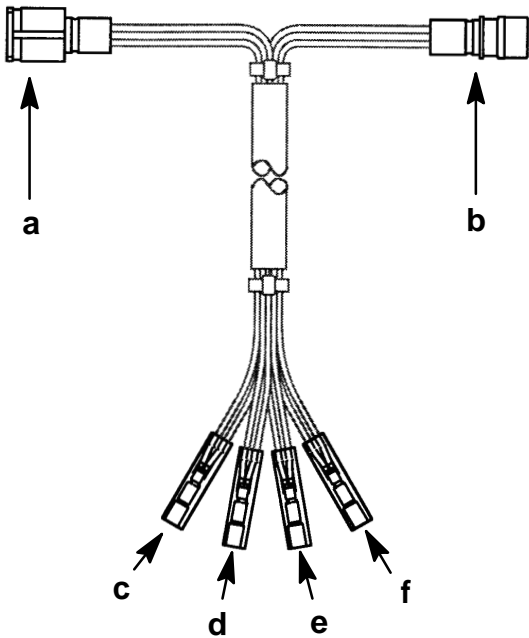

- a - To Injector Manifold
- b - To Engine Harness
- c - RED
- d - WHITE
- e - BLUE
- f - YELLOW

REQUIRED DFI SERVICE TOOLS

The required Direct Fuel Injection (DFI) tools will be mandatory for any dealer receiving DFI outboards.

- **DIGITAL DIAGNOSTIC TERMINAL (DDT)**
P/N 91-823686A2

The DDT has been used on Electronic Fuel Injection (EFI) and 3.0 Litre, Carbureted engines for over three years. The new sophisticated designs being introduced with the DFI product, have made the DDT an invaluable troubleshooting tool.

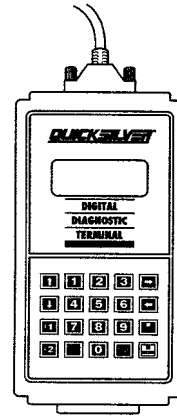

- **TEST HARNESS P/N 84-822560A5**

Harness is currently used with the DDT when servicing the 2.5 Litre EFI, and is also required for the DFI product.

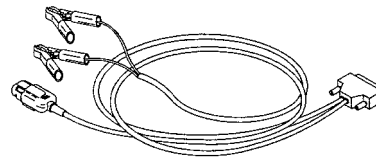

- **DDT CARTRIDGE P/N 91-822608--4**

This latest version, of the DDT cartridge will include all current product, that utilizes the DDT, in addition to 1998 products being introduced this year. Included with the cartridge is the DDT Technician Reference Manual P/N 91-825159-2.

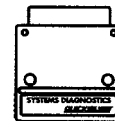

- TWIN GLYCERIN FILLED PRESSURE GAUGE
P/N 91-852087A1

This twin 160 psi glycerin filled pressure gauge will allow the technician to monitor air and fuel pressure simultaneously. This is an important part of troubleshooting DFI outboards. Gauge can also be used on Electronic Fuel Injection (EFI) outboards.

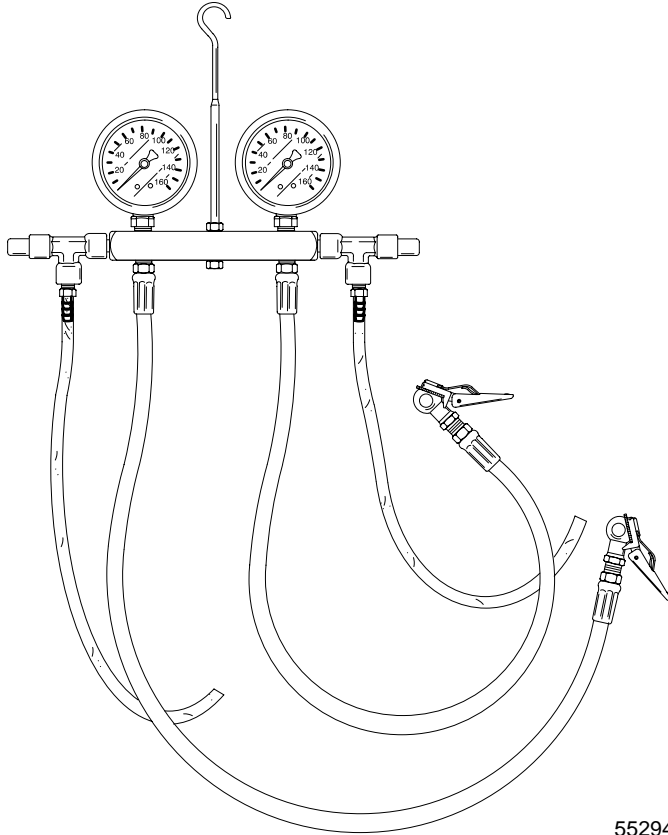

55294

- TEFLON SEAL INSTALLATION TOOL
P/N 91-851980

This tool is required when installing the Teflon seal onto the direct injector, used on DFI engines.

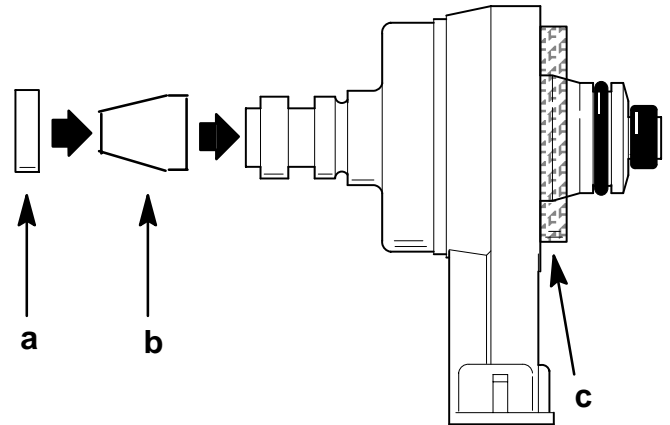

- a - Teflon Seal
- b - Seal Installation Tool
- c - Direct Injector

- DIRECT INJECTOR INSTALLATION TOOL
P/N 91-851980--1

This camp type tool is used to size a new, Teflon seal that has been installed onto a direct injector before installation of the injector into the cylinder head of a DFI outboard.

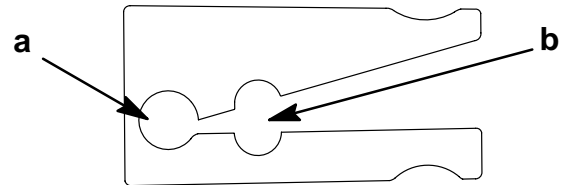

56014

- a - Pivot Point
- b - Seal Sizing Location