

Oil Injection Gear Failures – Sport Jet 175XR²

IMPORTANT: Service/repair information for the following models:

SPORTJET

175 hp Model
Serial Number 0E203000 & up

Problem

When repairing an oil injection gear failure, perform the following procedure in order to prevent recurrence of failure.

Inspection

Remove cylinder heads to inspect cylinder bore for scoring caused by lack of lubrication.

Correction

- If the cylinders are not damaged, replace the oil injection check valve, the crankshaft mounted drive gear, the driven gear, the drive gear bearing assembly, and the oil pump with worm bushing and o-ring. Thoroughly clean the crankcase and bleed system, inspect bronze bushing in cylinder block for damage, and check the warning horn system for proper operation.

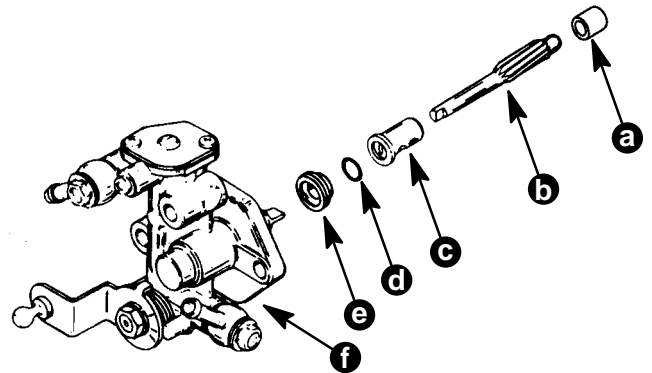

- a - Oil Pump Driven Gear Bushing Located in Cylinder Block
- b - Driven Gear
- c - Drive Gear Bearing Assembly
- d - O-Ring
- e - Worm Bushing
- f - Oil Pump

Check Valve Location

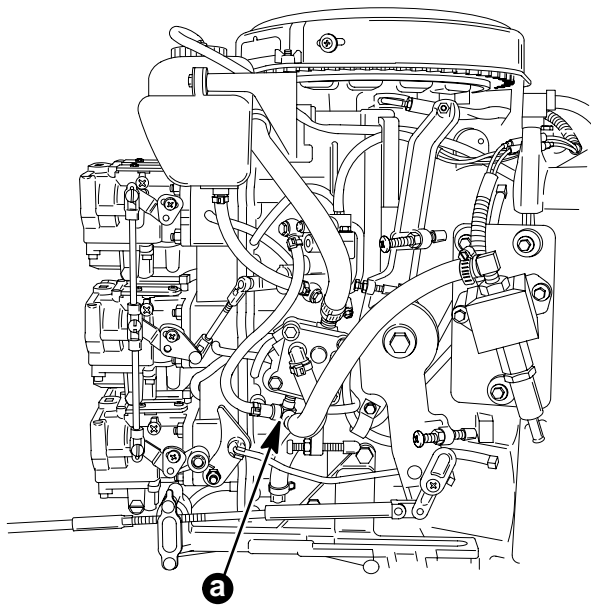

55087

a - Check Valve

- If the cylinders are damaged, repair or replace powerhead as appropriate, replace the oil injection check valve, oil pump, drive gear bearing assembly, and driven gear. Check the warning horn system for proper operation and instruct the customer on proper break-in procedure.

Parts Required

For Oil Injection Gear Replacement –

Qty. 1	P/N 22-814964	Tee Check Valve
Qty. 1	P/N 815699	Oil Pump
Qty. 1	P/N 23-41429A2	Drive gear bearing assembly
Qty. 1	P/N 43-14563	Driven gear
Qty. 1	P/N 43-14513A2	Drive gear

For Complete Powerhead Replacement –

Qty. 1	P/N (as applicable)	Powerhead Assembly
Qty. 1	P/N 22-814964	Tee Check Valve
Qty. 1	P/N 815699	Oil Pump
Qty. 1	P/N 23-41429A2	Drive gear bearing assembly
Qty. 1	P/N 43-14563	Driven gear

NOTE: This bulletin is informational only and is not intended as a service authorization or fix program.