

Hi-Performance MerCruiser Tailpipe Change

Models Affected

1999 Model Year Hi-Performance 500 C and 500 Bulldog Engine Packages.

Exhaust Tailpipe Change

Tailpipes on models listed above will have a higher rise built into the pipe but will exit the transom in the same location as previous tailpipes on Gil/MerCruiser exhausts. Hatch clearance should not be a problem since the top of the pipes do not extend above the flame arrester.

Although the extra pipe rise should help prevent water ingestion/reversion on installations that are marginal in water line to tailpipe height, it is still the responsibility of the installer to test for water ingestion problems. Internal exhaust shutters and external flappers are also required on all Hi-Performance exhaust installations.

IMPORTANT: The MerCruiser limited warranty does not cover engine damage due to water ingestion/reversion.

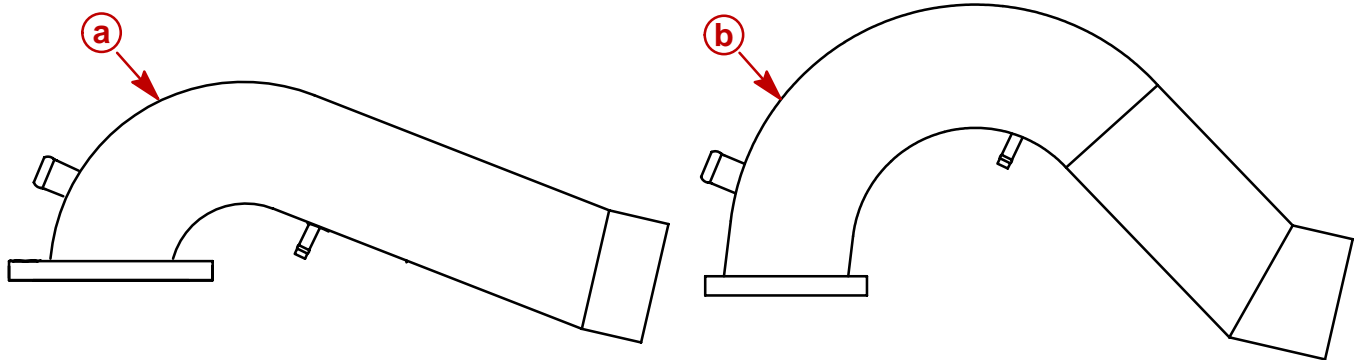

- a** - Standard Exhaust Pipe, 1998 & Below
- b** - Standard Exhaust Pipe 1999 & Above