

Circulate to: Sales Manager Accounting Service Manager Technician Parts Manager

Official Recall Notification of United States Federal Boat Safety Act Electronic Fuel Pumps on HP600/700 SCi Products

Models Affected

HP600SCi serial numbers 0M950332 through 0M955182

HP700SCi serial number 0M953679 through 0M955170 (**See Following Note**).

NOTE: All HP700SCi sterndrive products in the above serial number range have had the electronic fuel pumps replaced by the factory and require no further action regarding this recall.

Situation

The electronic fuel pumps on 600 SCi engines in the above listed serial number ranges may leak fuel around the positive (+) or negative (-) terminals of the pump causing a risk of fire or explosion.

Correction

If the engine serial number is in the range for this recall, check the engine history in MercNET to see if the recall is closed. If the recall is closed, no further action is required. If the recall is open, replace the fuel pump following the procedure in this bulletin and complete a warranty claim. The service replacement fuel pump includes the electrical harness installed on the pump to make installation easier as well as two new sealing O-rings for the straight and 90° fittings that connect to the pump.

Fuel Pump Removal and Installation

REMOVAL

1. Locate the fuel pump at the bottom front of the engine behind the harmonic balancer.

THE INFORMATION IN THIS DOCUMENT IS CONFIDENTIAL AND PROTECTED BY COPYRIGHT AND IS THE PROPERTY OF MERCURY MARINE.

This document is provided for the sole and exclusive use of the original recipient as prescribed by Mercury Marine and may not be distributed or copied, digitally or otherwise, without the prior written consent of Mercury Marine.

2. Use a fuel pressure gauge kit to relieve the fuel pressure at the Schrader valve on the rear of the intake manifold. Drain the fuel into a suitable container (approximately 0.5 L [1 pt.]) and dispose of the fuel in a safe manner.

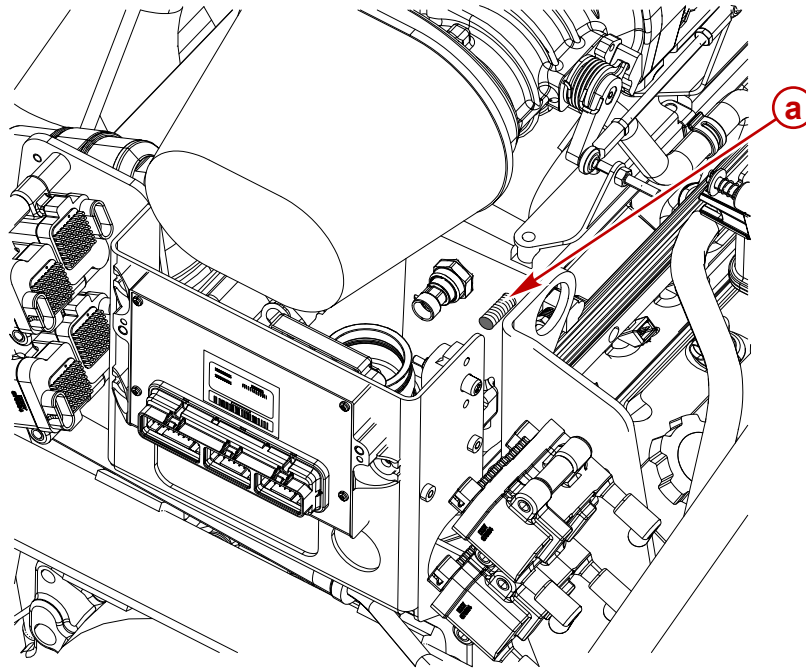

16854

a - Schrader valve

3. Disconnect the pump electrical harness at the fuel pump harness connector.

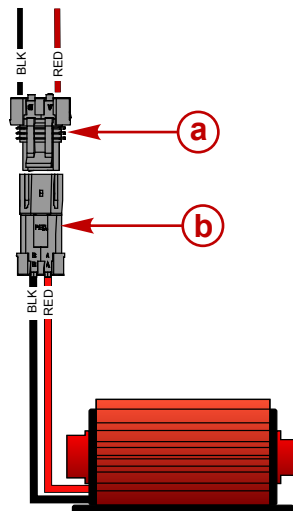

24932

a - Engine harness connector to fuel pump
b - Fuel pump harness connector

4. Remove the pump inlet and outlet fuel line hoses that connect to the pump's straight and 90° fittings.

THE INFORMATION IN THIS DOCUMENT IS CONFIDENTIAL AND PROTECTED BY COPYRIGHT AND IS THE PROPERTY OF MERCURY MARINE.

This document is provided for the sole and exclusive use of the original recipient as prescribed by Mercury Marine and may not be distributed or copied, digitally or otherwise, without the prior written consent of Mercury Marine.

5. Remove the four fasteners securing the pump and retain for installation of the new pump. If access to the four fuel pump fasteners is limited, remove the fuel pump bracket and pump as an assembly to gain access.

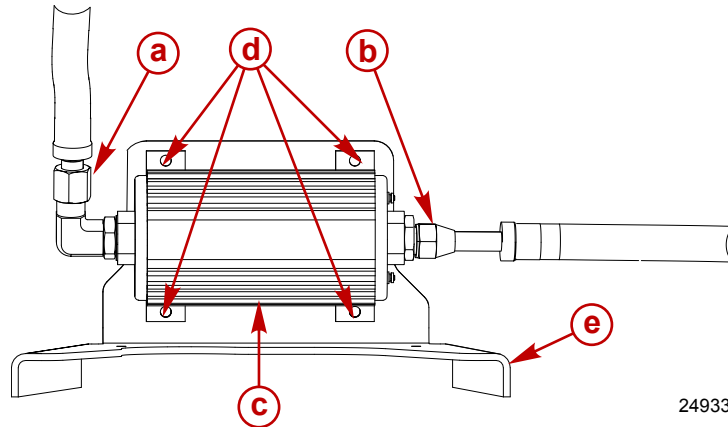

- | | |
|-----------------------------|--|
| a - Inlet fuel line | d - Fuel pump retaining fasteners |
| b - Outlet fuel line | e - Fuel pump bracket |
| c - Fuel pump | |

6. Remove both the straight and 90° fittings from the pump and retain for installation.

INSTALLATION

1. Install the straight fitting on the outlet end of the pump where the electrical connectors are located. Use a new O-ring, supplied with the pump, and Hi-Pressure Grease on the fitting threads. Securely tighten the fitting.
2. Assembling the fuel pump.
 - a. Install a new O-ring to the 90° fitting and apply Hi-Pressure Grease to the threads.
 - b. Loosen the locking nut in the direction of the elbow until it stops.
 - c. Install the fitting into the pump with an open end wrench on the flats of the elbow until securely tightened. Loosen the elbow until it is in the correct orientation to connect to the fuel inlet hose.

THE INFORMATION IN THIS DOCUMENT IS CONFIDENTIAL AND PROTECTED BY COPYRIGHT AND IS THE PROPERTY OF MERCURY MARINE.

This document is provided for the sole and exclusive use of the original recipient as prescribed by Mercury Marine and may not be distributed or copied, digitally or otherwise, without the prior written consent of Mercury Marine.

d. Tighten the elbow locknut securely to the pump.

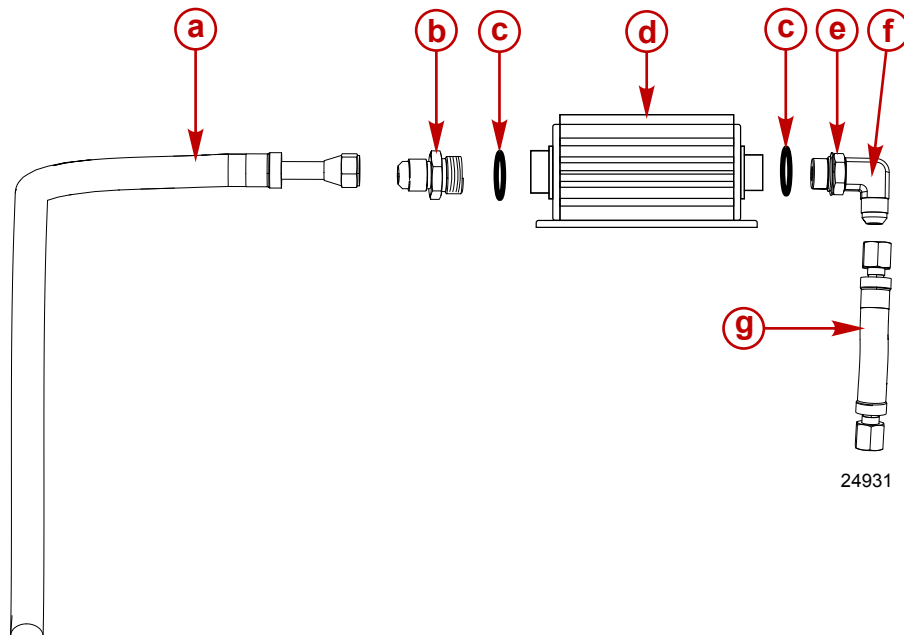

- a** - Fuel pump outlet hose
- b** - Fuel pump outlet straight connector
- c** - O-Ring
- d** - Fuel pump

- e** - Locknut for 90° fuel inlet fitting
- f** - 90° fuel inlet fitting
- g** - Fuel pump inlet hose

3. Secure the pump to the fuel pump bracket using Bostic Never-seez on the threads of the four fasteners from the original pump.
4. Secure the fuel pump bracket assembly to the engine if it was removed on disassembly.

THE INFORMATION IN THIS DOCUMENT IS CONFIDENTIAL AND PROTECTED BY COPYRIGHT AND IS THE PROPERTY OF MERCURY MARINE.

This document is provided for the sole and exclusive use of the original recipient as prescribed by Mercury Marine and may not be distributed or copied, digitally or otherwise, without the prior written consent of Mercury Marine.

- Install the inlet and outlet fuel lines to the pump using hi-pressure grease on the threads. Tighten securely.

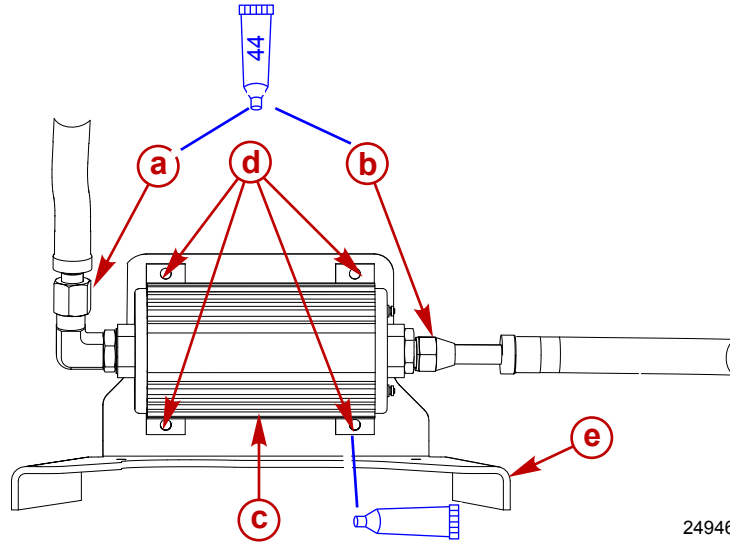

24946

- a** - Inlet fuel line
- b** - Outlet fuel line
- c** - Fuel pump
- d** - Fuel pump fasteners
- e** - Fuel pump bracket

Tube Ref No.	Description	Where Used	Part No.
 44	HI-Pressure Grease	Fuel lines and fittings	Obtain Locally

Tube Ref No.	Description	Where Used	Part No.
	Bostic Never-Seez	Fuel pump fastener threads	Obtain Locally

- Connect the fuel pump harness connector.

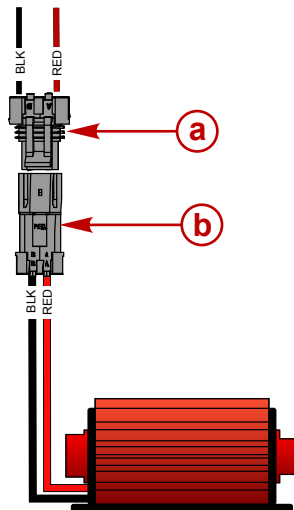

24932

- a** - Engine harness connector to fuel pump
- b** - Fuel pump harness connector

THE INFORMATION IN THIS DOCUMENT IS CONFIDENTIAL AND PROTECTED BY COPYRIGHT AND IS THE PROPERTY OF MERCURY MARINE.

This document is provided for the sole and exclusive use of the original recipient as prescribed by Mercury Marine and may not be distributed or copied, digitally or otherwise, without the prior written consent of Mercury Marine.

7. Pressurize the fuel system and inspect for leaks.

Warranty Information for the Fuel Pump Replacement

Submit a warranty claim including the following information:

- Engine Serial Number
- Fuel Pump Service Replacement Part Number 842243A02
- 1.0 hour labor
- Warranty Labor Code: PF18
- UFO Failure Code: 40
- UFO Part Code: 732

UNITED STATES AND CANADA

Complete the process and file a warranty claim via MercNET or return a warranty claim.

INTERNATIONAL

Follow instructions issued by the Marine Power International office or by your distributor.

Parts Return Procedure

UNITED STATES AND CANADA

Return with warranty claim.

INTERNATIONAL

Follow instructions issued by the Marine Power International office or by your distributor.

THE INFORMATION IN THIS DOCUMENT IS CONFIDENTIAL AND PROTECTED BY COPYRIGHT AND IS THE PROPERTY OF MERCURY MARINE.

This document is provided for the sole and exclusive use of the original recipient as prescribed by Mercury Marine and may not be distributed or copied, digitally or otherwise, without the prior written consent of Mercury Marine.